

LIFTING PRACTICES FOR ENGINEER



. S T U D E N T M A N U A L .

PREPARED BY: ASHRF AL MGHRLBL
EHS CONSULTANT

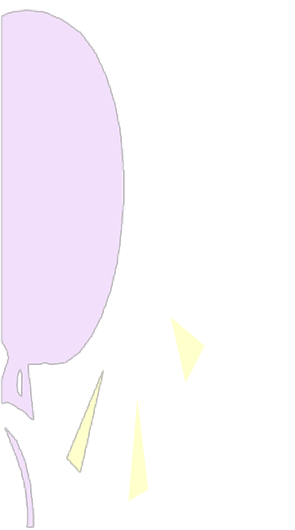
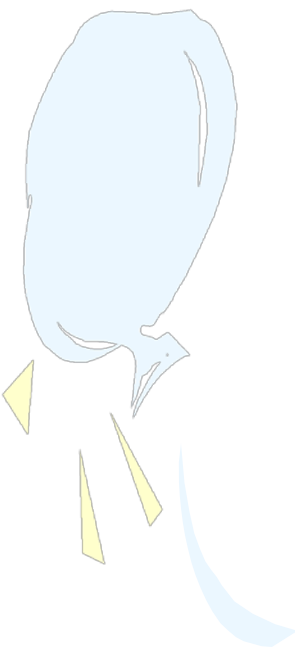
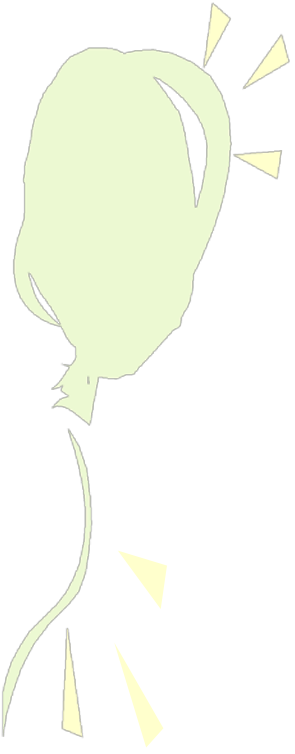



TABLE OF CONTENTS

1.	Introduction	3
2.	Duties and Responsibilities (Summarized)	4
3.	Safety Awareness	
3.1.	General	5
3.2.	Safety System	5
3.3.	Personal Protective Equipment	5
3.4.	Lifting Hazards	6
3.5.	Electrocution Hazard	8
3.6.	Overload and Maintenance Hazards	8
4.	Hand Signals	
4.1.	Hand or Radio Signal Policy	9
4.2.	Use of Standard Hand Signals	9
5.	Types of Hitches	13
6.	Wire Rope Slings	14
7.	Chain Slings	23
8.	Synthetic Flat Webbing	24
9.	Synthetic Round Slings	33
10.	Shackles	37
11.	Plate Clamps	41
12.	Hooks	45
13.	Eyebolts	48
14.	Turnbuckles	51
15.	Lifting Beam	52
16.	Beam Clamp	54
17.	Lifting Appliance	
17.1.	Hand-Operated Chain Block	57
17.2.	Chain Lever Hoist	61
17.3.	Wire Rope Grip/Pull Lifting Machine	64
17.4.	Familiarization of Crane Operation:	
17.4.1.	Basic Crane Configuration	66
17.4.2.	Basic Crane Function	66
17.5.	Familiarization of Crane Types:	
17.5.1.	Rough Terrain	67
17.5.2.	Tower crane	67
17.5.3.	Crawler Crane	68
17.5.4.	Offshore Crane	68



TABLE OF CONTENTS

18.	Load	
18.1.	Standard Signs Identification	69
18.2.	Container/Cargo Boxes	70
18.3.	Fuel/Chemical Tanks	70
18.4.	Gas Cylinder Rack	71
18.5.	Man Baskets	71
18.6.	Common Loads	
18.6.1.	Concrete and Muck Skips	72
18.6.2.	Scaffold Tubes	72
18.6.3.	Palletized Loads	72
18.6.4.	Beams	72
18.6.5.	Stillages	73
18.6.6.	Rubbish Skips	73
18.6.7.	Pipes	73
18.6.8.	Mesh	74
18.6.9.	Pre Fabricated Rebar Assemblies	74
18.6.10.	ISO Containers and Portable Offices	74
18.7.	Centre of Gravity	75
19.	Table/Chart	
19.1.	Shackle Angular Loading Capacity	76
19.2.	Conversion Table	77
19.3.	Formula Volume of Common Shapes	78
19.4.	Approximate Density of Common Materials	79
20.	Calculation	
20.1.	Example of Calculating of Sling Loading No. 1	80
20.2.	Example of Calculating of Sling Loading No. 2	81
20.3.	Sling Angles	82
21.	Glossary	83
22.	Lifting Plan Preparation	
23.	Lifting Law.	



1. INTRODUCTION

Knowledge of the equipment and materials with which we work is one of the most important factors in accident prevention. Each piece of equipment and material has been designed and developed to serve a specific purpose and knowledge of what it can and cannot do, not only improves efficiency but also eliminates hazards.

Owing to the many variations in rigging practices and the different ways in which rigging is used, recommendations must, of necessity, be framed in general terms. The recommendations can only be advisory in nature and are intended to complement relevant regulations and manufacturers' requirements which must be observed.

The rigger must apply his or her intelligence, common sense, and experience in anticipating what will happen when the load is moved. This thought process must take place before the work is started. In order to ensure the design of a safe and efficient system, the rigger must answer such question as:

1. What is to be done with load?
2. What will be the travel path of the load to reach the desired location?
3. How will the load be set down at the desired location?
4. How can the hookup be made?
5. What tools are needed to perform the desired task?
6. What other factors are involved (weather, electrical wires, sloping grades, visibility)?
7. Do the tools have the capacity to handle the loads and forces involved?
8. Are additional personnel needed to control the load safely during the Lifting process?

Four Basic Rules of Rigging

1. Know the Weight
2. Know the Capacity
3. Retain the Load
4. Control the Load

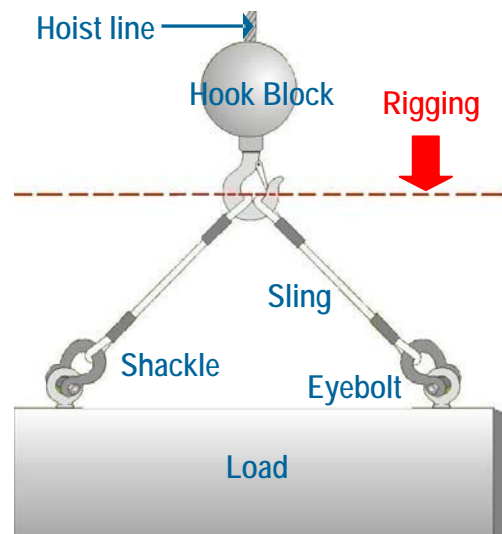



2. RIGGERS DUTIES AND RESPONSIBILITIES (SUMMARIZED)

- 01 **Observe all Safety Pre-cautions**
 - 🕒 Ensure you have the correct PPE to carry out your job on site.
 - 🕒 Observe All Safety Warning Signs and any Emergency Stop Signals from anyone
 - 🕒 Ensure that you aware of Fire fighting Equipment and
 - 🕒 First Aid Procedures (Emergency Contact number for Qatar is 999)
- 02 **Check the load to be lifted**
 - 🕒 Find the weight and Centre of Gravity (COG)
 - 🕒 Ensure that the hook is directly above the centre of gravity of the load prior to lifting, NO SIDE LOADING
 - 🕒 Identify the type of load, and locate the maximum radius.
- 03 **Check the working area**
 - 🕒 Identify the hazards (Power Lines, People, other Equipments and ground conditions.
- 04 **Inspect Rigging Gears and Lifting Equipment**
 - 🕒 Ensure that you carry out a Pre Use Check on Equipment to be used.
 - 🕒 Ensure that the equipment used has a valid Test Certificate and correct colour code.
- 05 **Attaching and Detaching Lifting Equipment**
 - 🕒 Always refer to the correct rigging information chart
 - 🕒 Identify the type of Hitch to be used (Choker, Vertical or Basket)
 - 🕒 Connect the load ensuring that the sling angle is appropriate to the capacity of the slings used.
- 06 **Communication between the Crane Operator and Rigger**
 - 🕒 Ensure that You and Crane Operator understand the correct standard signal being used.
 - 🕒 If you can not see the crane operator when carrying out lifts. Ensure that other means of communication are in place (Radio's and the Correct procedure for use)
- 07 **Secure and Maintain Lifting Equipment**
 - 🕒 After using any lifting equipment, Ensure that it is Cleaned and Returned in a Serviceable condition and Stored correctly.
- 08 **Reporting**
 - 🕒 Always ensure that you report anything that could be considered a Danger, Either with equipment on your pre-use check or by anything you have seen on your working site.
 - 🕒 Any defects found on any lifting equipment after use are to be reported and not to be used until certification. To ensure the equipment is safe to be used by a competent person.

3. SAFETY AWARENESS

3.1. GENERAL:

- Safe lifting and rigging often needs to be carried out at a height where danger from falling is greater than normal.

3.2. SAFETY SYSTEMS:

- A safety system could include either one or a combination of the following devices:

- ☐ Anchors and Inserts
- ☐ Ropes and Slings
- ☐ Lanyards and Shock absorbers Inertia reels (retractable lifelines)
- ☐ Tensioning devices
- ☐ Harnesses and Belts **Fig. 1**
- ☐ Safety nets **Fig. 2**
- ☐ Barricades or Guardrails **Fig. 3**



Fig. 1



Fig. 2



Fig. 3

3.3. PERSONAL PROTECTIVE EQUIPMENT (PPE)

- Personal protective equipment includes the following:
- ☐ Hard hat and safety shoes or boots to approved standard **Fig. 4 & 5**
- ☐ Close-fitting overalls or clothes and close-fitting leather gloves. **Fig. 6 & 7**
- ☐ Safety reflective vest. **Fig. 10**
- ☐ Ear and eye protection. **Fig. 8 & 9**



Fig. 4
Safety Shoes



Fig. 5
Safety Helmet



Fig. 6
Safety Overall



Fig. 7
Leather Gloves



Fig. 8
Ear and Eye Protection



Fig. 9
Eye Goggle



Fig. 10
Safety Reflective Vest

3. SAFETY AWARENESS

3.4. LIFTING HAZARDS:

- ⌚ Be aware of the Wind Speed and direction
- ⌚ The maximum wind capacity is 20 knots (QP regulations Revision 4, state 25 knots or 12.5m/sec) However, values set by individual crane manufactures. If Lesser, are to be used.
- ⌚ If the wind is above the recommended speed, then the rigging and crane operations will Not Be allowed to continue.
- ⌚ Be aware that for relatively large, light loads, there is a risk that the load will be blown about by the wind. (see Fig. 11)
- ⌚ Ensure all hands are free of lifting tackle and stand clear before the load strain is taken.
- ⌚ Stay back when slings are pulled out from under loads. (see Fig. 12)
- ⌚ Ensure that NO load is to be lifted where the weight is not stated or unknown. (see Fig. 13)
- ⌚ Observe & note other activities within the crane's operating area to avoid the development of any unforeseen hazards.
- ⌚ Check that the area around the load to be lifted is clear and that the load is not attached to the floor, transportation cradle or adjacent equipment. (see Fig. 14)
- ⌚ Ensure taglines are always attached to loads that are likely to swing, to control the load. (see Fig. 15)
- ⌚ Check slings are in good condition and adequate for load to be lifted.
- ⌚ Check for clear work area.
- ⌚ Ensure the load is equally distributed.
- ⌚ Provide packing to prevent sling damage.
- ⌚ The load should be placed on timber dunnage. (see Fig. 15)

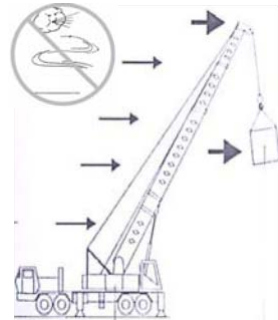

Fig. 11

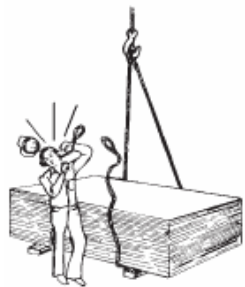

Fig. 12

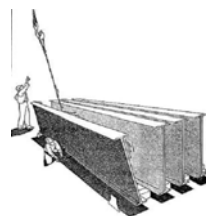

Fig. 13



Fig. 14

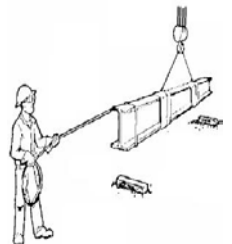

Fig. 15

3. SAFETY AWARENESS

3.4. LIFTING HAZARDS: (cont.)

During the Lift

- 🕒 The load can now be lifted and moved to its landing area, while in the air, avoid:
 - Where possible, passing over personnel working on the site
 - The public
 - Power lines
 - Projecting scaffolding
 - Air space violation

Landing the Load

- 🕒 The load should be landed gently to ensure that it is not damaged and that the crane does not receive any shock loading.
- 🕒 Before landing the load, check that:
 - ☐ The landing area will take the weight of the load
 - ☐ There is sufficient space for the load
 - ☐ There are strips of timber or similar on which to land this load so that the slings can be easily removed by hand.
- 🕒 The Rigger must ensure that he is in a place of safety when receiving the load, ensuring that he cannot be crushed between the load and a fixed object or pushed over an open edge.

After the Lift

- 🕒 Only authorized Riggers are to detach the slings from the load.
- 🕒 Take care with bundles of tubes and similar items as they can collapse when landed and pipes can roll, so make sure suitable chocks are used to prevent this from happening.
- 🕒 The legs of the sling should now be hooked back onto the master link, shackle etc on the crane hook, or removed and stored properly.

3.SAFETY AWARENESS

3.5. ELECTROCUTION HAZARDS:

- ⌚ If a Rigger has to work near Power Lines, he must ensure that all safety measures are taken and that safety procedures are in place.
- ⌚ Clearly indicate to the crane operator where the load has to be moved / placed and, where possible the Rigger should follow each load to its destination.
- ⌚ A rigging component or a wire rope that has been contacted by an electric arc must be removed until certified safe for continue use by a competent person.
- ⌚ The machine is not insulated.
- ⌚ Accident electrocutions are amongst the most frequently repeated crane accidents.
- ⌚ Most of these are caused when the boom contacts or approaches too close to over head power lines.
- ⌚ The fatality rate is high, particularly among riggers guiding the load.
- ⌚ While the danger is greater from high voltage transmission lines, where flash over can occur without actual contact. Fatal accident have resulted from contact with 440 volts and 220 volts service lines.
- ⌚ The safe procedure is to request the local electrical authority to cut off the power. If for any reason this is not possible or practical, and it is necessary for cranes to work close to hot power lines, then all safety precautions are to be set in place.
- ⌚ Crane operating near high voltage power lines for guide lines, follow the Manufacturers table

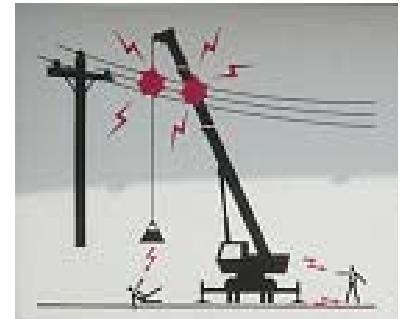

Fig. 16

3.6. OVER LOAD & FOR MAINTENANCE HAZARDS:

- ⌚ Be familiar with the lifting capabilities of the crane.
- ⌚ Be aware of any obstructions within the crane radius and working area.
- ⌚ No personnel are allowed below the load whilst lifting is in progress



Fig. 17

4. HAND SIGNALS

4.1. HAND OR RADIO SIGNAL POLICY:

- 4.1.1. Ensure that both the Rigger and Crane Operator are familiar with the Method of Signaling to be used.
- 4.1.2. Always use clear and distinct signals (either by Hand or by Radio) to control lifting operations.
- 4.1.3. If radios are chosen, then the following method of use must be followed. All instructions must be repeated continuously, for example "LOWER, LOWER, LOWER..." until the movement is complete. If the instructions stop getting through to the crane operator, he should immediately bring the load to a HALT. This will guard against failure of the radio system.
- 4.1.4. In poor light conditions ALL hand signal shall be exaggerated
- 4.1.5. Clearly indicate to the Crane Operator where the load has to be moved / placed and, where possible, he should follow each load to its destination
- 4.1.6. When lifting a load. Stop the load just clear of the ground to check security and balance of the load, and check the proper function of the crane's hoist brakes.
- 4.1.7. Stop the lifting operation if anything out of the ordinary occurs and check that it is safe to continue the operation.
- 4.1.8. When working at night, a reflective orange glove is useful for making hand signals more visible.

4.2. ALWAYS USE THE STANDARD HAND SIGNALS:



Fig. 1 HOIST. With forearm vertical, forefinger pointing up, move hand in small horizontal circle

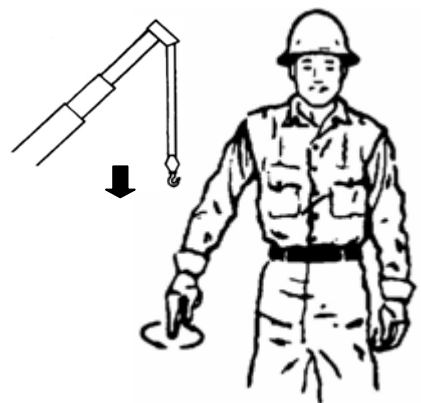

Fig. 2 LOWER. With arm extended downward, forefinger pointing down, move hand in small horizontal circle

4. HAND SIGNALS

4.2. ALWAYS USE THE STANDARD HAND SIGNALS:



Fig. 3 USE MAIN HOIST. Tap fist on head; then use regular signals



Fig. 4 USE WHIPLINE (Auxiliary Hoist). Tap elbow with one hand ; then use regular signals

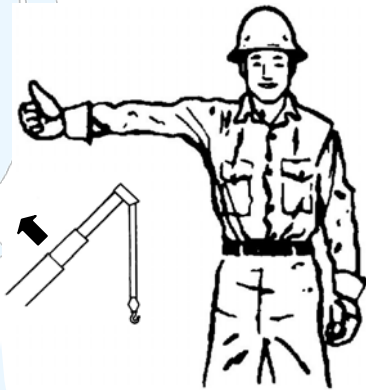

Fig. 5 RAISE BOOM. Arm extended, fingers closed, thumb pointing upward.

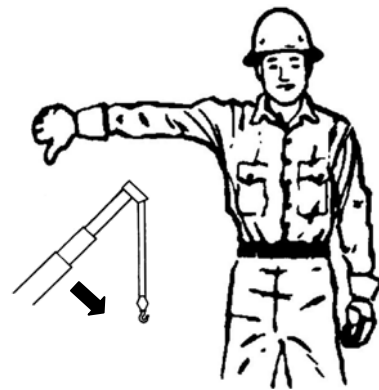

Fig. 6 LOWER BOOM. Arm extended, fingers closed, thumb pointing downward.

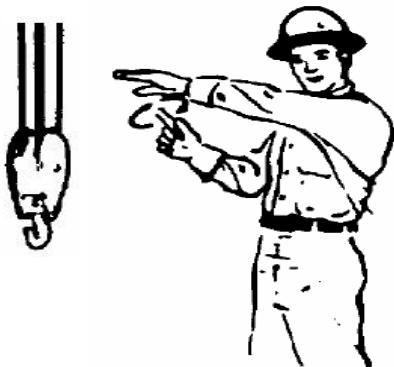

Fig. 7 MOVE SLOWLY. Use one hand to give any motion signal and place other hand motionless in front of hand giving the motion signal. (Hoist slowly shown as example)

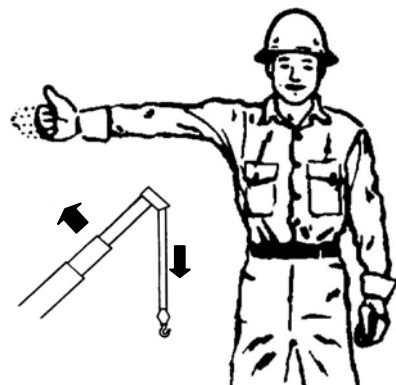

Fig. 8 RAISE THE BOOM AND LOWER THE LOAD. With arm extended, thumb pointing up, flex fingers in and out as long as load movement is desired

4. HAND SIGNALS

4.2. ALWAYS USE THE STANDARD HAND SIGNALS: (cont.)

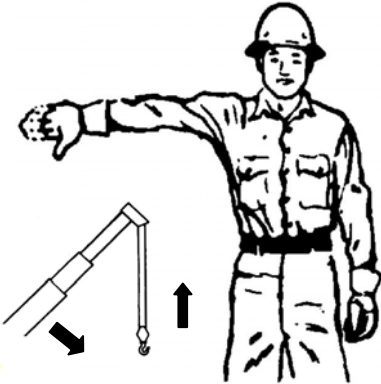

Fig. 9 LOWER THE BOOM AND RAISE THE LOAD. With arm extended, thumb pointing down, flex fingers in and out as long as load movement is desired

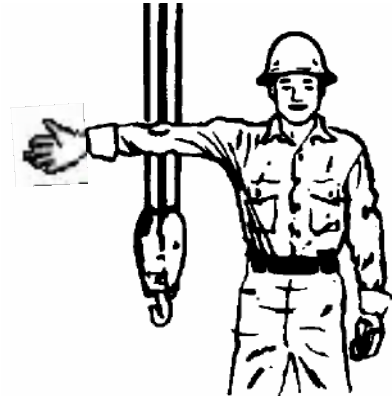

Fig. 10 SWING. Arm extended, pointing the direction of swing of boom.

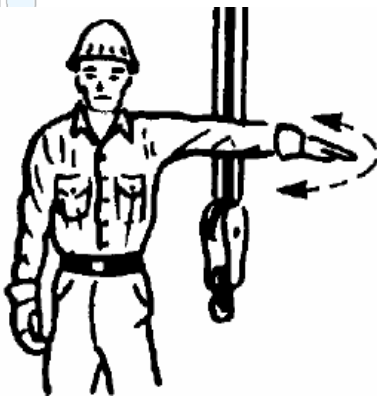

Fig. 11 STOP. Arm extended, palm down, move arm back and forth horizontally.

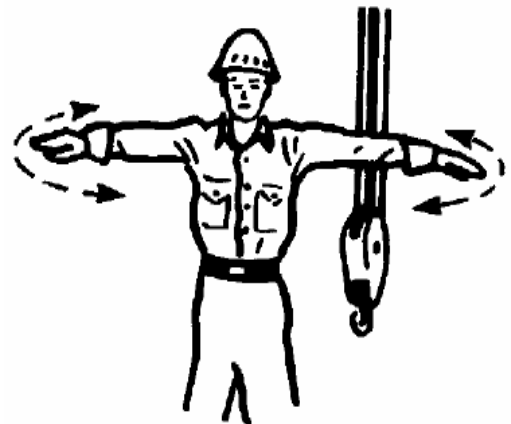

Fig. 12 EMERGENCY STOP. Both arms extended, palms down, move arms back and forth horizontally.

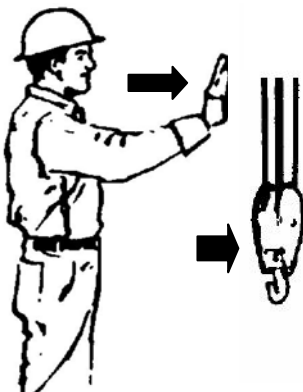

Fig. 13 TRAVEL. Arm extended forward, hand open and slightly raised, make pushing motion in direction of travel

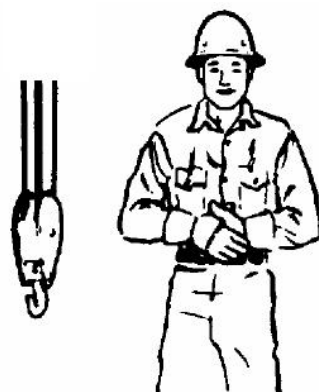

Fig. 14 DOG EVERYTHING. Clasp hands in front of Body

4. HAND SIGNALS

4.2. ALWAYS USE THE STANDARD HAND SIGNALS: (cont.)

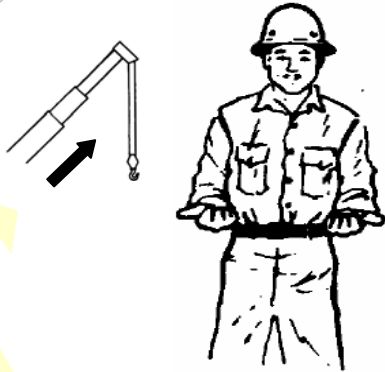

Fig. 15 **EXTEND BOOM (Telescoping Booms)**. Both fists in front of body with thumbs pointing outward.

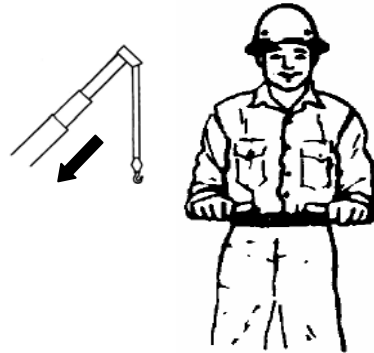

Fig. 16 **RETRACT BOOM (Telescoping Booms)**. Both fists in front of body with thumbs pointing toward each other.



Fig. 17 **TRAVEL (Both Tracks)**. Use both fists in front of body, making a circular motion about each other, indicating direction of travel, forward or backward. (For land crane only)



Fig. 18 **TRAVEL (One Tracks)**. Lock on side indicated by raised fist. Travel opposite track in direction indicated by circular motion of other fist, rotated vertically in front of body. (For land crane only)

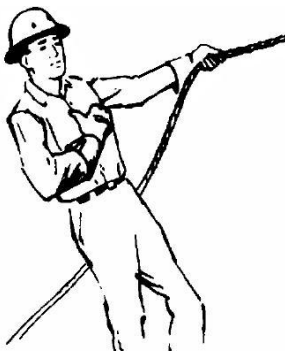

Fig. 19 **EXTEND BOOM (Telescoping Boom) One Hand Signal**. One fist in front of chest, with thumb tapping chest.



Fig. 20 **RETRACT BOOM (Telescoping Boom) One Hand Signal**. One fist in front of chest, thumb pointing outward and heel of fist tapping chest.

5. TYPES OF HITCHES

APPLICATION/RIGGING METHOD:

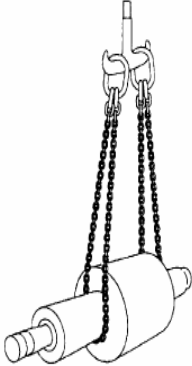

Fig. 1



Fig. 2



Fig. 3

BASKET HITCHES

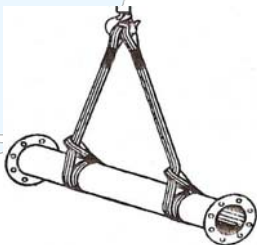

Fig. 4

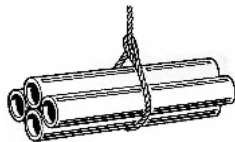

Fig. 5

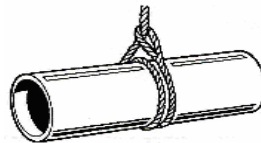

Fig. 6

Metal Mesh Slings



Fig. 7

CHOKER HITCHES

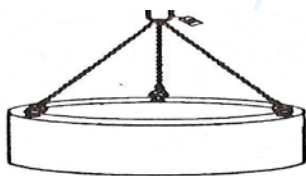

Fig. 8

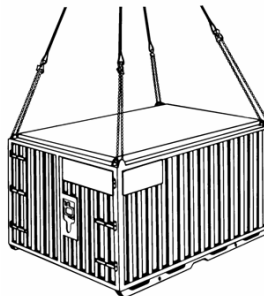

Fig. 9

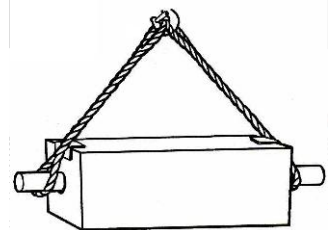
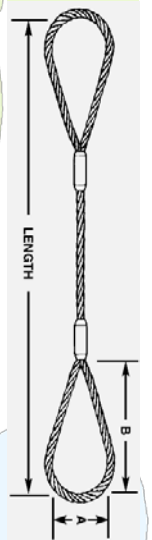

Fig. 10

BRIDLE HITCHES

6. WIRE ROPE SLING

6.1. TYPE:



SINGLE-LEG SLING
Fig. 1

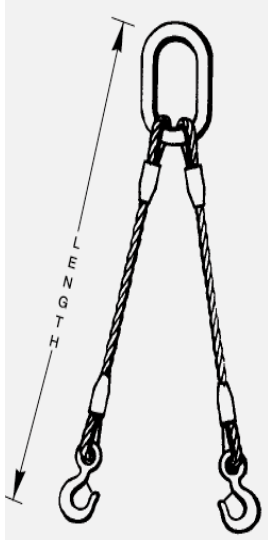

TWO-LEG SLING

Fig. 2

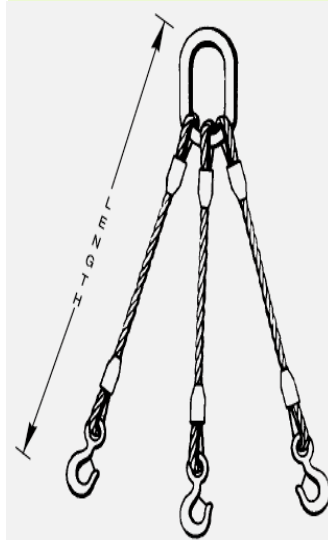

THREE-LEG SLING

Fig. 3

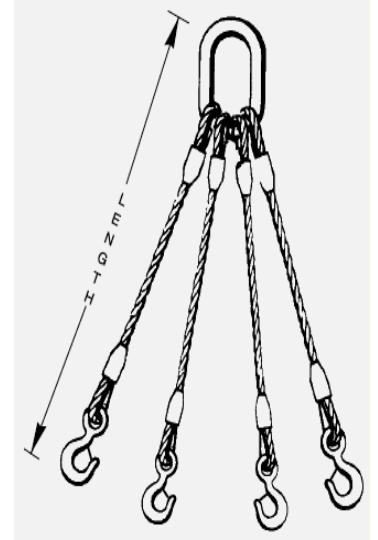

FOUR-LEG SLING

Fig. 4

6.2. IDENTIFICATION:

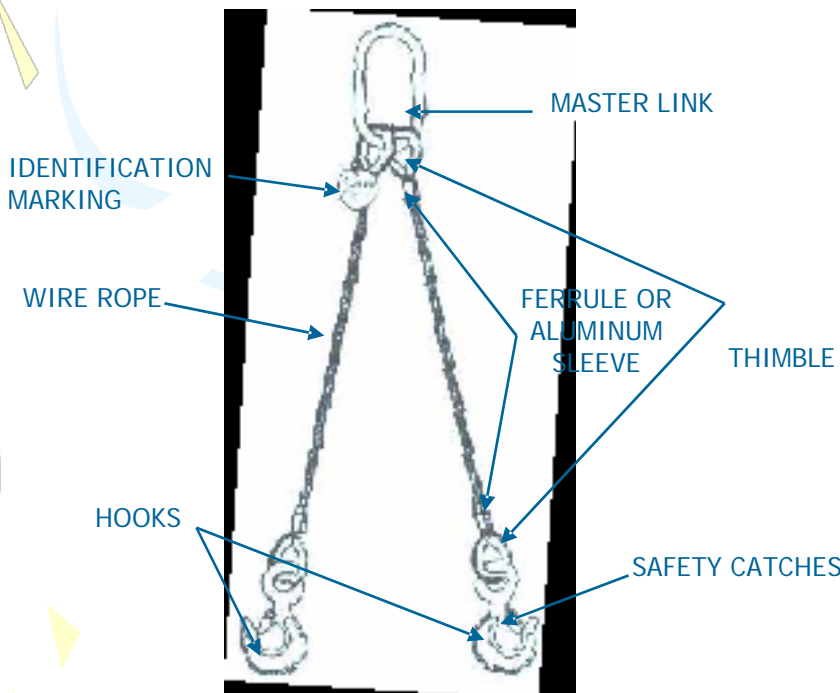

Fig. 5

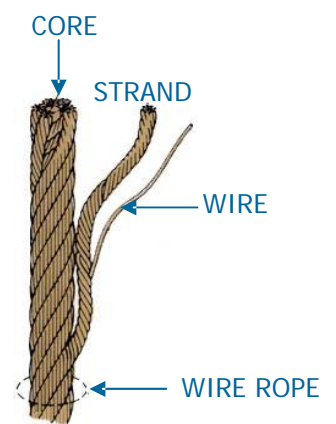

Fig. 6

6. WIRE ROPE SLING

6.3. TERMINATION IDENTIFICATION:

6.3.1. Formation of Eyes:

6.3.1.1. Ferrule-secured eye slings – The minimum length of plain rope between the inside ends of ferrules terminating a sling leg shall be 20 times the nominal rope diameter.

6.3.1.2. Spliced eye slings – The minimum length of plain rope between the tails of splices shall be at least 15 times the nominal diameter.

6.3.1.3. Hard eyes – Hard eyes shall be fitted with thimbles.

6.3.1.4. Soft eyes – The peripheral length of a soft eye shall be at least four rope lay lengths.

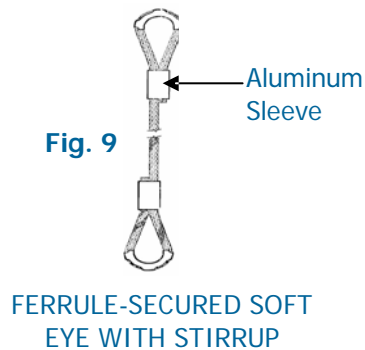
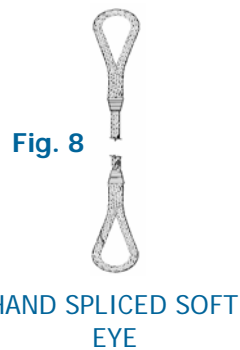
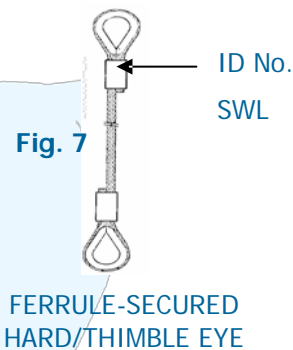

6.3.1.5. Terminal Fittings:

- The working load limit of any master link shall be at least equal to that of the sling SWL.
- The working load limit of any intermediate link fitted to a three-leg or four-leg sling shall be at least equal to 1.6 times the WLL of one of the legs suspended from it.
- The working load limit of the lower terminal fitting(s) shall be at least equal to that of the leg(s) to which it is/they are fitted.

AT UPPER END

AT LOWER END

NOMINAL LENGTH OF SLING LEG
(bearing to bearing)

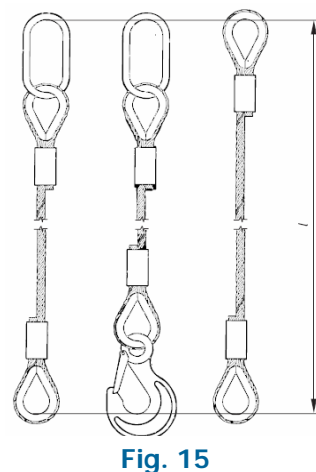
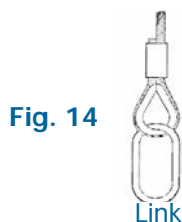
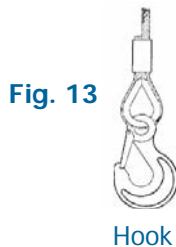
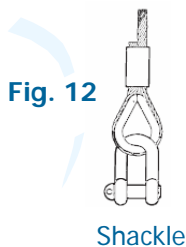
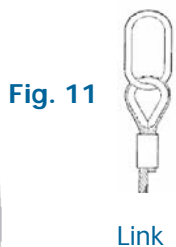

6. WIRE ROPE SLING

6.4. WIRE ROPE TYPES:

Independent Wire Rope Core (IWRC)

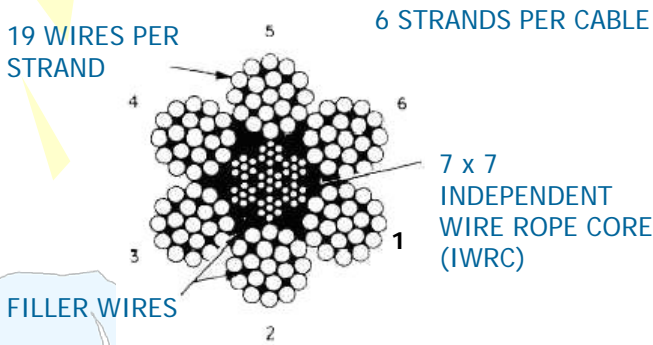

Fig. 16

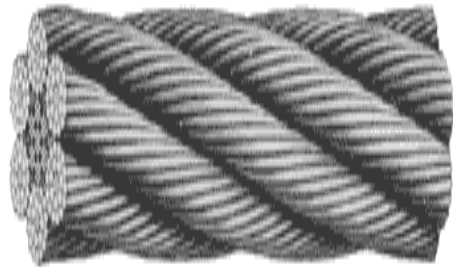

Fig. 17

6 x 19 (IWRC)

Fiber Core Wire Ropes (FC)

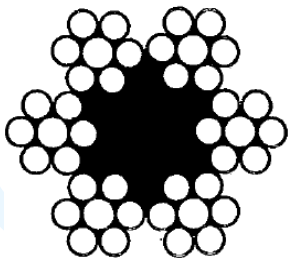

Fig. 18

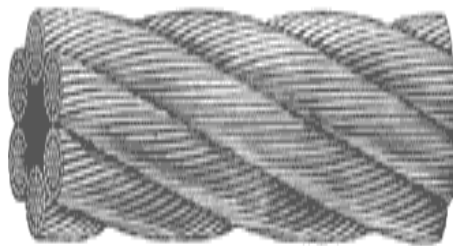

Fig. 19

6 x 7 (FC)

Composed with:

- Improved Plow Steel (IPS)
- Extra Improved Plow Steel (EIPS)
- Extra Extra Improved Plow Steel (EEIPS)

6. WIRE ROPE SLING

6.5. INSPECTION:

Check and Recommend for Replacement if found any one of the following:

- ≡ Heat damage, discoloration, loss of lubricant
- ≡ More than 10% reduction in rope original diameter
- ≡ High external corrosion, internal corrosion
- ≡ Severe distortion-kinks, crushes, knots, bird cages
- ≡ More than maximum allowed broken wires
- ≡ Exposure of core, internal damage
- ≡ Core protrusion as a result of torsional unbalance created by shock loading.
- ≡ Where the surface wires are worn by 1/3 or more of their diameter, the rope must be replaced.
- ≡ 6 or more randomly broken wires in one lay.
- ≡ 3 or more broken wires in one strand in one lay.
- ≡ 3 or more broken wires in one lay in standing ropes.

- 🕒 Estimate rope's condition at section showing maximum deterioration.

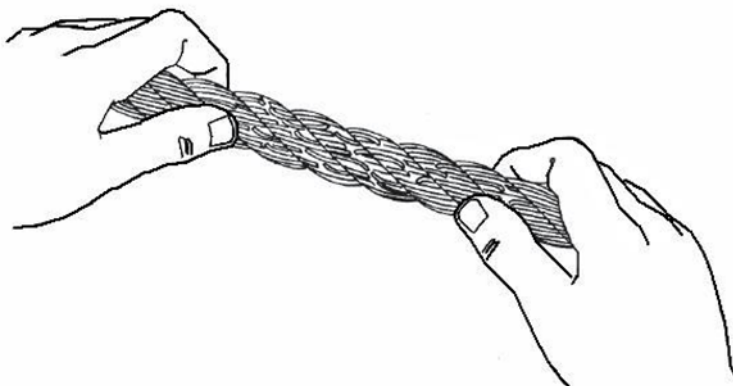

Fig. 26



Fig. 20
Core protrusion



Worn section

Fig. 21



Enlarged view of Single Strand

Fig. 22



Protrusion of core resulting from shock loading.

Fig. 23



Bird cages

Fig. 24



Multi-Strand rope
"Bird cages"

Fig. 25

6. WIRE ROPE SLING

6.5. INSPECTION: (cont.)

TERMINATIONS

1. Eyes

- ⌚ Distortion
- ⌚ Excessive wear, damage to thimble

2. Securing

- ⌚ Any broken wires near to the ferrules/splice
- ⌚ Broken/damaged ferrules or pulling out
- ⌚ Crushing, abrasion of splice, pulling out

3. Links (master & intermediate)

- ⌚ More than 5% stretch of original length of links
- ⌚ More than 8% wear in links
- ⌚ Bent or twisted links

③ Correct Way – this gives correct diameter.

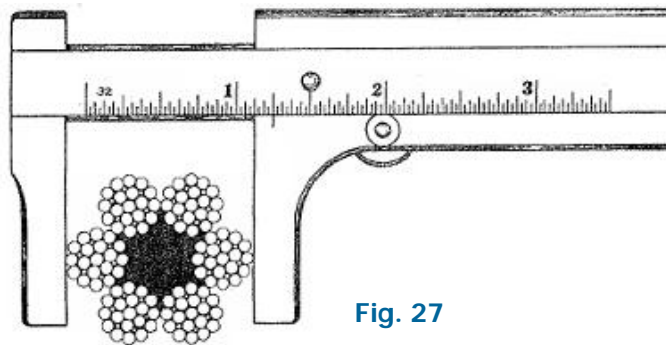

Fig. 27

③ Incorrect Way – this does NOT give correct diameter.

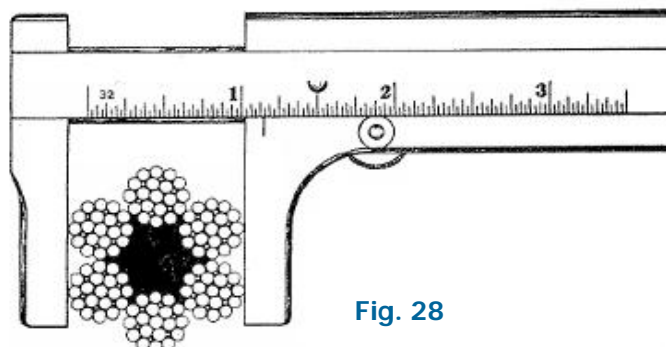
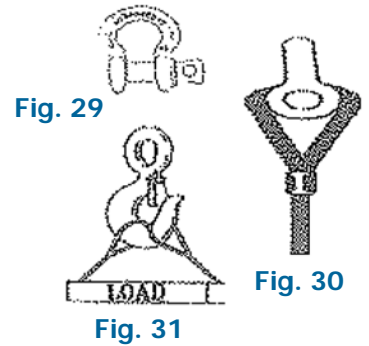

Fig. 28

6. WIRE ROPE SLING

6.6 APPLICATION/RIGGING METHOD:

- Use a thimble to protect sling and to increase D/d ratio.
- Never place sling eye over a fitting with a smaller diameter than the rope's diameter.
- Never place a sling eye greater than one half the natural length.



- A basket hitch has twice the capacity of a single leg only if the D/d ratio $\geq 25/1$ and legs of sling are vertical.

(at other angles, see Table)

ANGLE β	PERCENTAGE OF SINGLE LEG CAPACITY
0	200%
30	170%
45	140%
60	100%

- A choker hitch has 80% of the capacity of a single leg only if the corners are softened and the vertical sling angle β is smaller than 60° .

- Use blocks to prevent angles greater than 60° . (at other angles, see Table)

ANGLE OF CHOKE	SLING RATED LOAD PERCENTAGE OF SINGLE LEG SLING CAPACITY
$120^\circ - 180^\circ$	80%
$90^\circ - 119^\circ$	65%
$60^\circ - 89^\circ$	55%
$30^\circ - 59^\circ$	40%

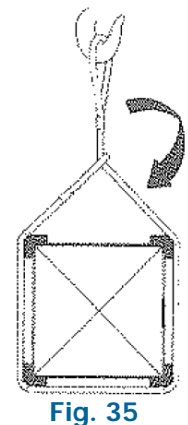
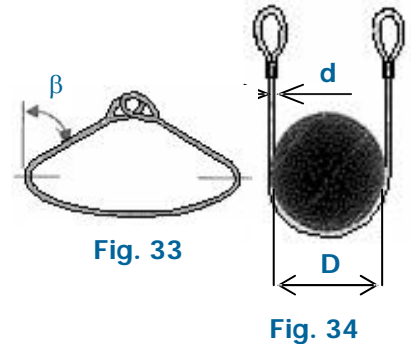

6. WIRE ROPE SLING

6.6. APPLICATION/RIGGING METHOD: (cont.)

1. Straight Vertical Hitch - The total weight of the load is carried by a single leg.

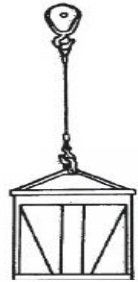

Fig. 36

2. Single-Leg Sling
Single Choke Hitch – This forms a noose in the rope and tightens as the load is lifted.



Fig. 37

3. Single-Leg Sling
Double Choke Hitch



Fig. 38

4. Endless-Leg Sling
Double Choke Hitch

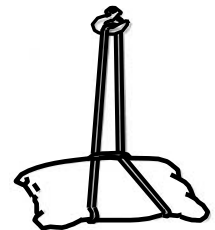

Fig. 39

5. Two-Leg Sling
Double Basket Hitch



Fig. 40

6. WIRE ROPE SLING

6.6. APPLICATION/RIGGING METHOD: (cont.)

6. **Bridle Hitch** – Two, Three, or Four Single leg slings can be used together to form a bridle hitch.

CAUTION:

- Load may be carried by only 2 legs while 3rd and 4th merely balance it. (Fig 42) Four Points Lift

7. **Single Basket Hitch** – This hitch is ideal for loads with inherent stabilizing characteristics. The load is automatically equalized.

8. **Double Basket Hitch** – Consists of two single basket hitches passed under the load. The legs of the hitches must be kept far enough apart to provide balance without opening excessive sling angles.

9. **Double Wrap Basket Hitch** – A basket hitch that is wrapped completely around the load. This method is excellent for handling loose materials, pipes, rods, or smooth cylindrical loads.

10. **Double Choker Hitch** – Consists of two single chokers attached to the load and spread to provide load stability.

11. **Double Wrap Choker Hitch** – The rope or chain is wrapped completely around the load before being hooked into the vertical part of the sling. Do not run the sling through the hook, permitting an unbalanced load to tip.

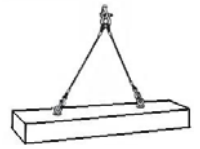

Fig. 41

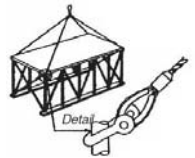

Fig. 42

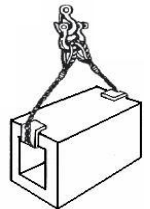
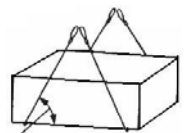

Fig. 43



60° or more

Fig. 44



Fig. 45

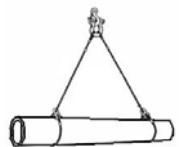

Fig. 46

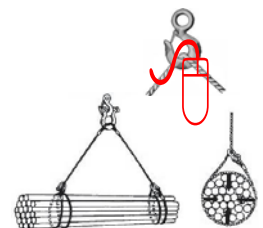

Fig. 47

6. WIRE ROPE SLING

6.6. APPLICATION/RIGGING METHOD: (cont.)

12. Three-Leg Slings Straight Lift, (SWL)

Capacity as per Rigging chart tables depending on included angle.

β = Beta Angle from the vertical.

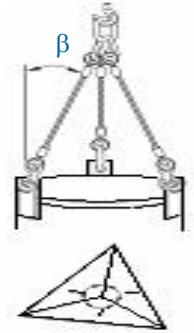

Fig. 48

13. Four-Leg Slings Straight Lift, (SWL)

Capacity as per Rigging chart tables depending on included angle.

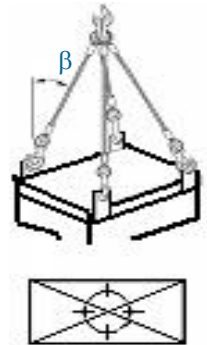

Fig. 49

WIRE ROPE SLING

NEVER:

- Overload a wire rope sling-allow for angles & mode of use
- Force or hammer into position
- Join wire ropes with opposite lay
- Use twisted or kinked ropes
- Attempt to shorten, knot or tie a wire rope sling

FIBRE ROPE SLING

NEVER:

- Overload a fiber rope sling allow for angles & mode of use
- Attempt to shorten, knot or tie a fiber rope sling
- Use around sharp edge without protection
- Expose to direct heat
- Wrap a rope around a hook.



NO HAMMERING
Fig. 50

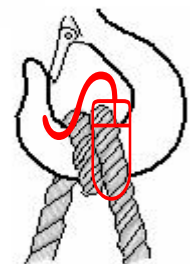

No Wrap Roping
Fig. 51

7. CHAIN SLING

7.1. TYPE:

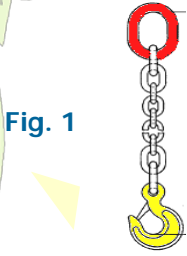

Fig. 1

SINGLE-
LEG SLING

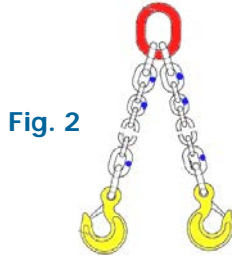

Fig. 2

TWO-LEG
SLING

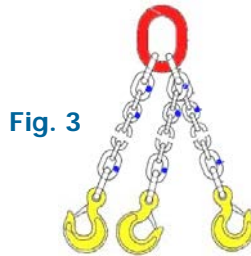

Fig. 3

THREE-LEG
SLING



Fig. 4

FOUR-LEG
SLING

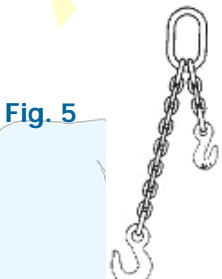

Fig. 5

SINGLE
ADJUSTABLE SLING

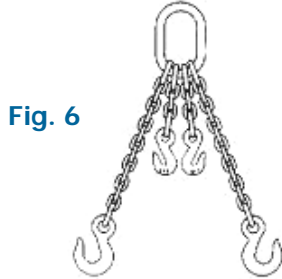

Fig. 6

DOUBLE
ADJUSTABLE SLING

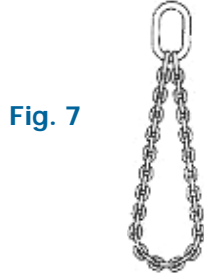

Fig. 7

SINGLE BASKET

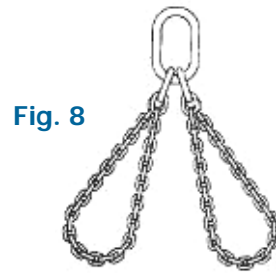

Fig. 8

DOUBLE BASKET

7.2. IDENTIFICATION:

IDENTIFICATION MARKING

Number of
chain legs

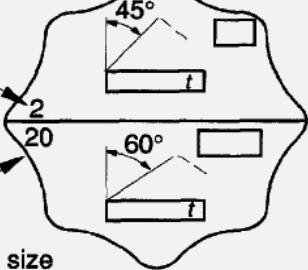

Code number
denoting nominal size
of chain, in mm

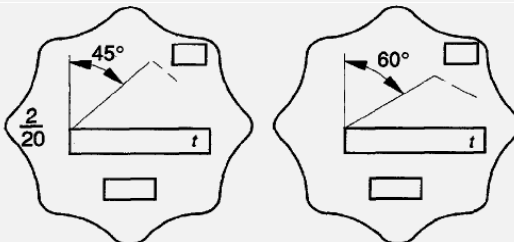

Fig. 10

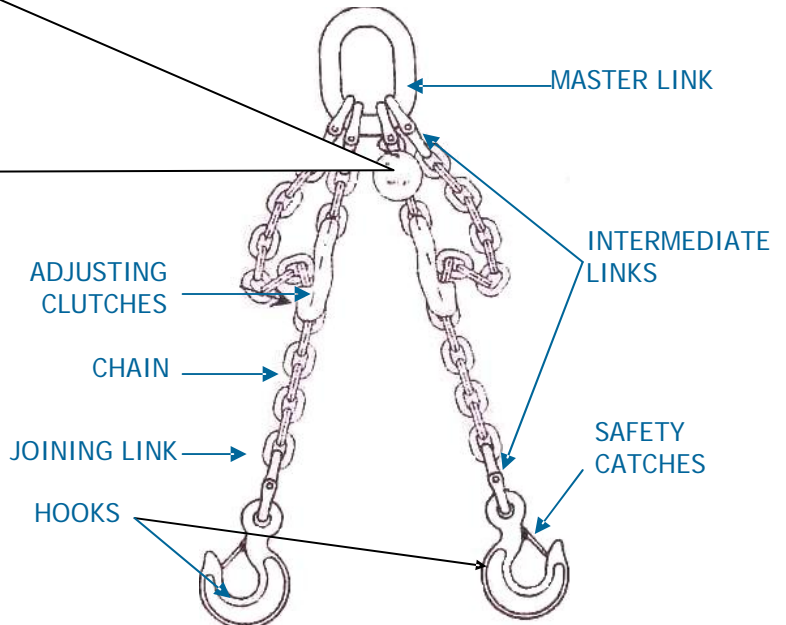

Fig. 9

7. CHAIN SLING

7.3. INSPECTION:

Mechanical Joined:

Check and Recommend for Replacement if found any one of the following:

- ☐ More than 5% stretch of original length (terminal, joining, intermediate links, chain and hooks)
- ☐ More than 8% diameter wear of terminal, joining, intermediate links, chain and hooks
- ☐ Existence of nicks, cracks and gouges in terminal, joining, intermediate links and chain
- ☐ Bent, elongated or twisted links, rings
- ☐ Lack of free articulation between links
- ☐ Distortion of terminal fittings
- ☐ Cracks and faults in welded areas
- ☐ Excessive corrosion
- ☐ Heat discoloration
- ☐ Broken, twisted chain
- ☐ Improper shortening devices
- ☐ Repairs by welding
- ☐ Rusty chain

Welded Chain:

Check For:

- ☐ More than 8% wear of terminal fittings, joining links
- ☐ Existence of nicks, cracks, gouges in terminal fittings, joining links
- ☐ Bent, elongated or twisted joining links
- ☐ Distortion of terminal fittings
- ☐ Replaced parts not manufacturer certified

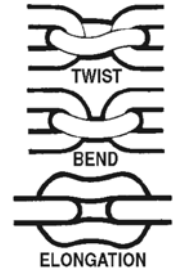
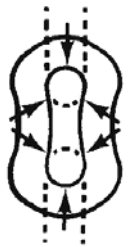

Fig. 11



MASTER LINK
WEAR POINTS

Fig. 12



FREEZE POINTS ON
DEFORMED LINK

Where worn chain deforms and binds.

Fig. 13



DRAG WEAR
Metal has been removed by abrasion.

Fig. 14

7. CHAIN SLING

7.4. APPLICATION/RIGGING METHOD:

SINGLE-LEG SLINGS

1. Straight Lift – Safe Working Load

- The SWL will be 100% SWL of a single-leg.
- A suitable method of lifting an a effectively balanced load from a single lifting point. (see Fig. 15)



Fig. 15

2. Choke Hitch

- The SWL must be reduced by 20% in this application. (80% SWL of a single leg)
- This method forms a loop which tightens as the load is lifted.
- Do not attempt to force the bight into closer contact with the load. Choker hitch is not suitable for lifting long loads which might tilt. (see Fig. 16)



Fig. 16

SINGLE-LEG SLINGS IN BASKET HITCH

3. Single leg in Basket Hitch (back hooked into top link)

- The SWL will be rated by that of a single-leg sling reduced by the included angle.
- A single-leg sling back hooked to form a basket hitch assumes the appearance of a two-leg sling but it should never be rated as such. It should be noted that the master link is only designed for single leg loading and therefore the single leg WLL should never be exceeded. (see Fig. 17)

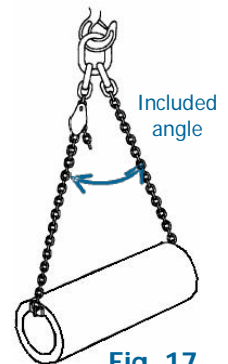

Fig. 17

4. Double Wrap Sling in Basket Hitch

- The SWL will be that for a two-leg sling reduced by the included angle. (see Fig. 18)

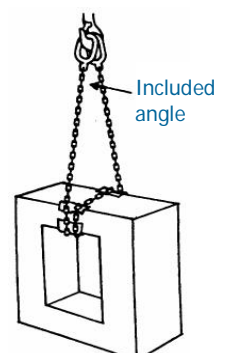

Fig. 18

7. CHAIN SLING

7.4. APPLICATION/RIGGING METHOD: (cont.)

5. Single Adjustable Basket Sling (see Fig. 19)

- The SWL will be that for a two-leg sling reduced by the included angle.
- A suitable master link must be fitted for two-leg rating. (see Fig. 19)

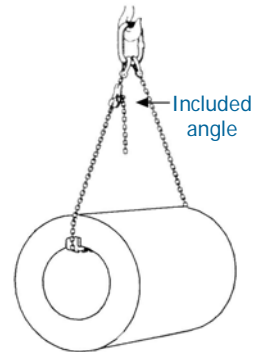

Fig. 19

TWO SINGLE-LEG SLINGS USED TOGETHER

6. Two Single Legs in Straight Lift (see Fig. 20)

- Rate as a two-leg sling.
- The SWL will therefore depend upon the included angle.

Two single-leg slings should not be used together to form a pair unless:

- They are of the same type, grade, size and length.
- They are both marked with the same SWL.
- The crane hook is large enough to comfortably accept both upper terminal fittings of the slings.

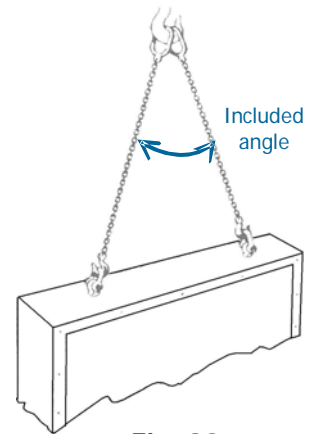

Fig. 20

7. Two Single-Leg in Choke Hitch (see Fig. 21)

- SWL calculated as per No.6 then reduced by 20% because it is choked, for loose items double wrap is recommended.
- The SWL will be reduced by 20% in the application.
- Choke hitch with included angle greater than 60° Included angle is not recommended as sideways shifting may occur.
- Two single-leg slings should not be used together to form a pair unless:
 1. They are of the same type, grade, size and length.
 2. They are both marked with the same SWL.
 3. The crane hook is large enough to comfortably accept both upper terminal fittings of the slings.

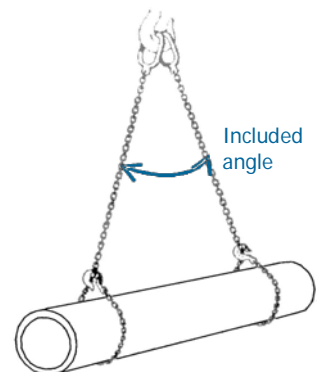

Fig. 21

7. CHAIN SLING

7.4. APPLICATION/RIGGING METHOD: (cont.)

8. Two Single Legs in Basket Hitch (see Fig. 22)

- Rate as a two-leg sling. The SWL should be no more than that applicable to an equivalent two-leg sling.
- Two single-leg slings should not be used together to form a pair unless:
 1. They are of the same type, grade, size and length.
 2. They are both marked with the same SWL.
 3. The crane hook is large enough to comfortably accept both upper terminal fittings of the slings.

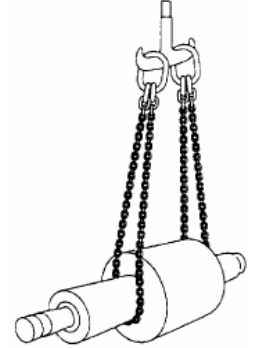

Fig. 22

DOUBLE-LEG SLINGS

1. BRIDLE HITCH (see Fig. 23)

- For two-legged slings, the angle between the legs of the sling will determine its safe working load (SWL).
- A two-legged sling will be marked with its SWL at 90° (45° with vertical), which will apply for all angles from $0^\circ - 90^\circ$ ($0^\circ - 45^\circ$ with vertical).
- It may also be marked with its SWL at 120° which will apply for angles between $90^\circ - 120^\circ$ ($45^\circ - 60^\circ$ with vertical).
- **Note** that the SWL for a two-legged sling assumes that both legs are equally loaded, and that each leg is straight.

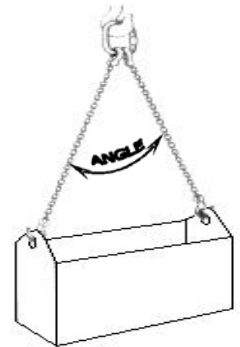

Fig. 23

2. Choke Hitch (see Fig. 24)

- When using slings in choke hitch multiply the marked SWL by 0.8 to obtain the reduced maximum load the sling may lift or the angle between the legs of the sling will determine its SWL
- For loose items or a better grip, double wrap is recommended.

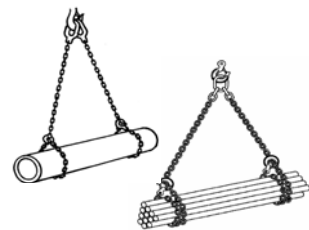

Fig. 24

3. Basket Hitch (see Fig. 25)

- Capacity as per Rigging chart table depending on included angle
- Be aware of minimum pin diameter for basket hitch.
- The sling assumes the appearance of a four-leg sling but it should be noted that the master link will be designed for two-legs load only and sling should therefore be rated as a two-leg sling.

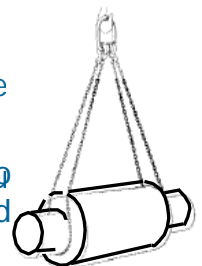

Fig. 25

7. CHAIN SLING

7.4. APPLICATION/RIGGING METHOD: (cont.)

THREE-LEG SLINGS (see Fig. 26 & 27)

Choke Hitch

When using slings in choke hitch multiply the marked SWL by 0.8 to obtain the reduced maximum load the sling may lift or reduce the safe working load by 20%. If three legs are obviously supporting most of the load, rate as a three-leg sling.

- For three-legged slings, the maximum angle between the legs of the sling and the vertical will determine its safe working load (SWL).
- A three-legged sling will be marked with its SWL at 45° , which will apply for all angles from 0° to 45° .
- Note** that the SWL for a three-legged sling assumes that all legs are equally loaded, and that each leg is at the same angle.

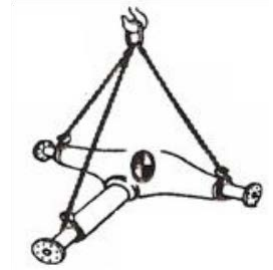

Fig. 26

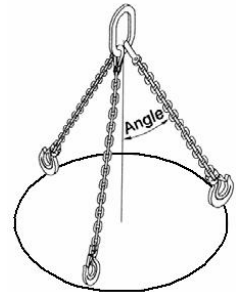

Fig. 27

FOUR-LEG SLINGS (see Fig. 28 & 29)

Straight Lift

- SWL as per Rigging load chart tables depending on the included angle.
- The included angle should be measured between diagonally opposite legs. SWL as indicated above only in cases where the load appears to be reasonably equally distributed between all four legs. If two legs are obviously supporting most of the load, rate as a two-leg sling. If three legs are obviously supporting most of the load, rate as a three-leg sling.
- For four-legged slings, the maximum angle between opposite legs of the will determine its safe working load (SWL).
- A four-legged sling will be marked with its SWL at 90° (45° with vertical), which will apply for all angles from 0° to check sling angle 90° ($0^\circ - 45^\circ$ with vertical).
- It may also be marked with its SWL at 120° which will apply for angles between 90° and 120° ($45^\circ - 60^\circ$ with vertical).
- Note** that the SWL for a four-legged sling assumes that all legs are equally loaded, and that each leg is straight.

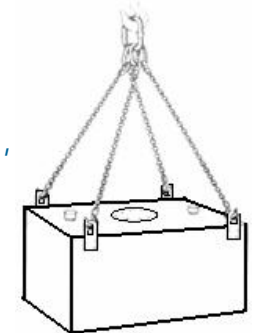

Fig. 28

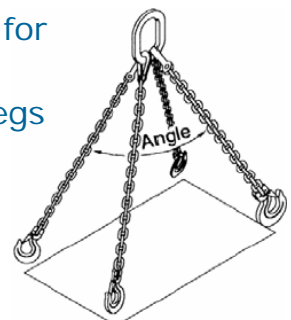

Fig. 29

8. SYNTHETIC FLAT WEBBING SLING

8.1. TYPE & IDENTIFICATION:



VIOLET
1 TONNE
Fig. 1

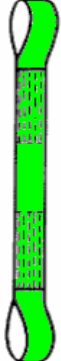

GREEN
2 TONNE
Fig. 2

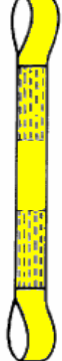

YELLOW
3 TONNE
Fig. 3



GREY
4 TONNE
Fig. 4



RED
5 TONNE
Fig. 5



BROWN
6 TONNE
Fig. 6



BLUE
8 TONNE
Fig. 7



ORANGE
10 TONNE
Fig. 8

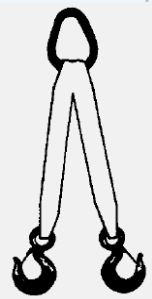

MULTI-LEG BRIDLE SLINGS
Fig. 9



Fig. 10

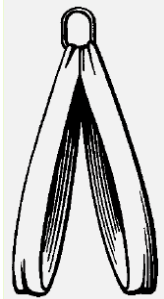
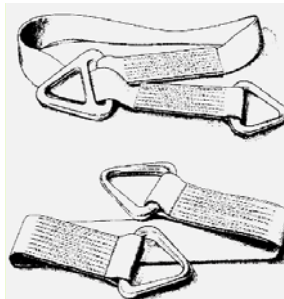

Fig. 11



TRIANGLE AND
CHOKER WEB SLINGS
Fig. 12



VERTICAL
SLING
Fig. 13



CHOKER SLING
Fig. 14



Fig. 15

GREEN

NYLON

Resists Alkalis



Fig. 16

BLUE

POLYESTER

Resists Acids

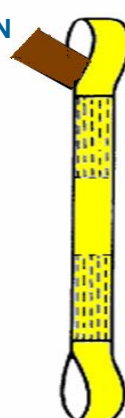

Fig. 17

BROWN

POLYPROPOLYNE

Resists Alkalis & Acids. Is suitable where the highest resistance to chemicals, other than solvents is required

8. SYNTHETIC FLAT WEBBING SLING

8.2. INSPECTION:

Eye to eye reinforcement damaged, chafed or cut

Marking illegible

Heat damage including hard shiny areas due to friction

Stitching damaged or loose

Webbing damaged, frayed, signs of chemical attack or solar degradation

Webbing cut

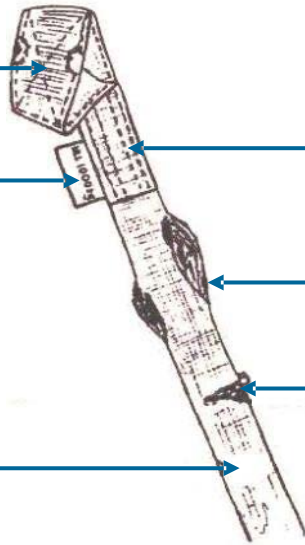

Fig. 18

Check and Recommend for Replacement if found

any one of the following:

- ☐ Acid or Caustic Burns
- ☐ Melting or charring
- ☐ Holes, cuts
- ☐ Tears, snags
- ☐ Broken stitches
- ☐ Worn stitches
- ☐ Excessive abrasion
- ☐ Knots
- ☐ Cut – a clean break in the webbing structure of fibers. This usually results when a sling contacts a sharp object or unprotected edge of a load. (see fig. 19)
- ☐ Tensile Break – a frayed close to the point of failure or damage. (see fig. 20)
- ☐ Cut and Tensile Damage – a cut by a sharp object along one edge of the sling body. (see fig. 21)



Fig. 19



Fig. 20

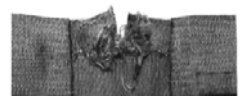

Fig. 21

8. SYNTHETIC FLAT WEBBING SLING

8.2. INSPECTION: (cont.)

- ⊞ Abrasion Damage – frayed fibers on the surface exposing the “picks” or cross fibers, of the webbing that hold the load-bearing (length wise) fibers in place. Occurs either when the sling slips while in contact with a load during a lift or when the sling is pulled from under a load. (see fig. 22)

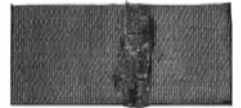

Fig. 22

- ⊞ Acid Damage – nylon and polyester webbing should never be exposed to any strong acids or corrosive liquids whenever possible. (see fig. 23 & 24)



DROPPED BY ACID

Fig. 23



IMMERSED IN ACID

Fig. 24

8.3. APPLICATION/RIGGING METHOD:

- 🕒 Material – polyester is resistant to moderate strength acids but is damaged by alkalis; polyamide (Nylon) is virtually immune to alkalis but is damaged by acids; and polypropylene is little affected by acids or alkalis but is damaged by some solvents, tars or paints.
- 🕒 Capacity – the sling must be both long enough and strong enough for the load and the slinging method.
- 🕒 Apply the mode factor for the slinging method.
- 🕒 If the slings are used in multi-leg arrangement the angle formed between the legs should not be less than 30° from Horizontal angle or greater than 90° from Included angle.



8. SYNTHETIC FLAT WEBBING SLING

8.3. APPLICATION/RIGGING METHOD: (cont.)

ALWAYS:

- 🕒 Store and handle slings correctly.
- 🕒 Inspect slings and accessories before use and before placing into storage.
- 🕒 Always follow safe slinging practices.
- 🕒 Connect the sling over 120° angle of choke

Never:

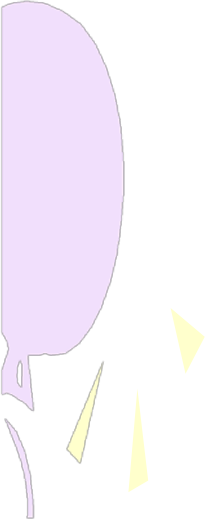
- 🕒 Attempt to shorten, knot or slings.
 - 🕒 Expose slings to direct heat or flames.
 - 🕒 Use slings at temperature above 80°C or below 0°C without consulting the supplier.
 - 🕒 Expose slings to chemicals without consulting the supplier.
 - 🕒 Shock load slings
 - 🕒 Use slings which are cut or which have loose or damaged stitching.
- 

9. SYNTHETIC ROUND SLING

9.1. TYPE:



Violet
1 TONNE
Fig. 25



Green
2 TONNE
Fig. 26



Yellow
3 TONNE
Fig. 27



Gray
4 TONNE
Fig. 28



Red
5 TONNE
Fig. 29



Brown
6 TONNE
Fig. 30



Blue
8 TONNE
Fig. 31



Orange
10 TONNE
Fig. 32

9.2. IDENTIFICATION:

Protective Sleeve

Identification
Marking

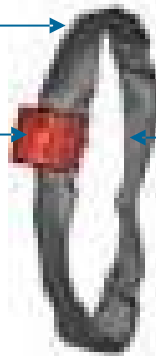

Inner core

Fig. 33

9.3. INSPECTION:

Initial Inspection – before any polyester round sling is placed into service it shall be inspected by a designated person to ensure that the correct polyester round sling is being used, as well as to determine that the polyester round sling meets the requirements of the manufacturer's specification.

Frequent Visual Inspection – This inspection shall be made by the person handling the polyester round sling each time the round sling is used.

Periodic Inspection – This inspection shall be conducted by a designated person.

Frequency of inspection should be based on:

1. Frequency of use.
2. Severity of service conditions.
3. Experience gained on service life of polyester round slings used in similar applications.
4. periodic inspections should be conducted at least monthly.

9. SYNTHETIC ROUND SLING

9.3. INSPECTION: (cont.)

- **Check and Recommend for Replacement if found any one of the following:**

1. If polyester round sling's identification tag is missing or unreadable.
2. Melting, charring or weld spatter on any part of the polyester round sling.
3. Holes, tears, cuts, embedded particles, abrasive wear, or snags that expose the core fibers of the polyester round sling.
4. Broken or worn stitching in the cover which exposes the core fibers.
5. Polyester round slings that are knotted.
6. Acid or Alkali burns on the polyester round sling.
7. Any conditions which cause doubt as to the strength of the polyester round sling.

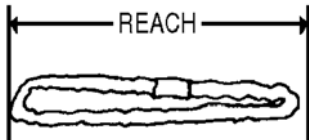

Fig. 34



Fig. 35



Fig. 36



Fig. 37

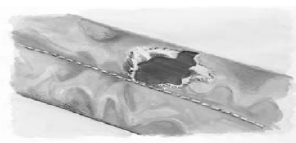

Fig. 38

9. SYNTHETIC ROUND SLING

9.4. APPLICATION/RIGGING METHOD:

ROUND SLING – are available in a range of materials and sizes in endless sling form. Select the slings to be used and plan the lift taking the following into account:

- ⌚ Material – polyester is resistant to moderate strength acids but is damaged by alkalis; polyamide (Nylon) is virtually immune to alkalis but is damaged by acids; polypropylene is affected by acids or alkalis but is damaged by some solvents, tars and paints.
- ⌚ Capacity – the sling must be both long enough and strong enough for the load and the slinging method.
- ⌚ Apply the mode factor for the slinging method.
If the slings are to be used in multi-leg arrangement the angle formed between the legs should not be less than 30° or greater than 90°.

ALWAYS:

- ⌚ Inspect carefully the round slings and accessories before use and before placing into storage.
- ⌚ Follow safe slinging practices, as given overleaf.
- ⌚ Position the bight for choke lift over 120° angle of choke.
- ⌚ Apply correct mode factor for the slinging arrangement.
- ⌚ Use protection (to avoid cutting, friction etc) and fittings which allow the sling to form smooth radii.

NEVER:

- ⌚ Attempt to shorten, knot or tie round slings.
- ⌚ Expose round slings to direct heat or flames.
- ⌚ Use round slings at temperatures above 80°C or below 0°C without consulting the supplier.
- ⌚ Expose round slings to chemicals without consulting the Manufacturer.
- ⌚ Shock load round slings.
- ⌚ Use round slings with cut or damaged outer covers.

9. SYNTHETIC ROUND SLING

9.4. APPLICATION/RIGGING METHOD: (cont.)

ROUND SLING – shall not be constricted or bunched between the ears of a clevis or shackle or in a hook.

- ⌚ The opening of fitting shall be proper shape and size to ensure that the fitting will seat properly on the round sling.

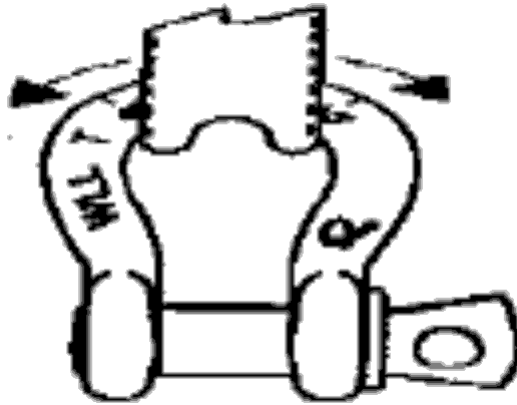

BUNCHING

Fig. 39

SYNTHETIC SLING RATED LOAD: (SWL)

- ⌚ Folding, bunching or pinching of synthetic slings, which occurs when used with shackles, hooks or other applications will reduce the rated load.



PINCHING

Fig. 40

10. SHACKLES

10.1. TYPE:

DEE SHACKLES			BOW SHACKLES		
					
Fig. 1 Safety Pin Dee	Fig. 2 Round Pin Dee	Fig. 3 Screw Pin Dee	Fig. 4 Safety Pin Bow	Fig. 5 Round Pin Bow	Fig. 6 Screw Pin Bow

10.2. IDENTIFICATION:

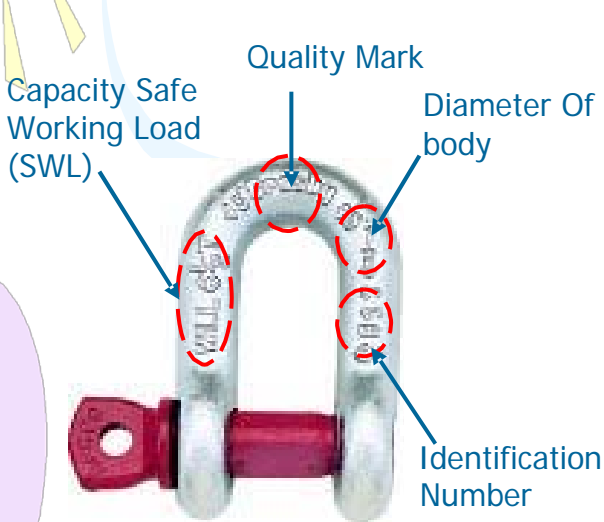

Fig. 7
DEE SHACKLE

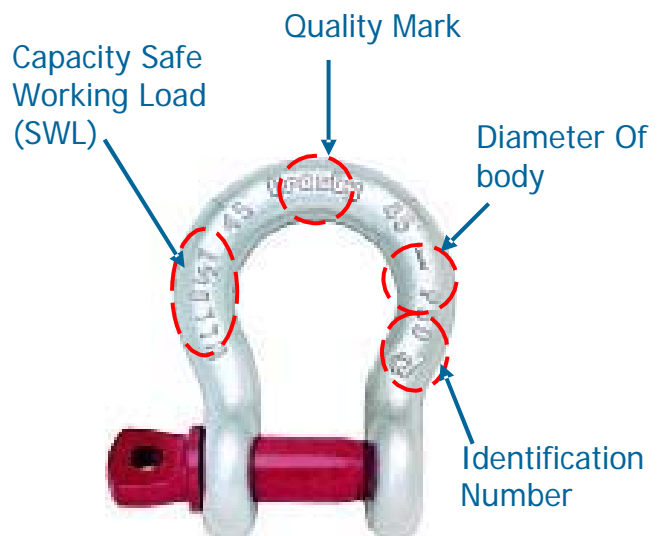

Fig. 8
BOW SHACKLE

10. SHACKLES

10.3. INSPECTION:

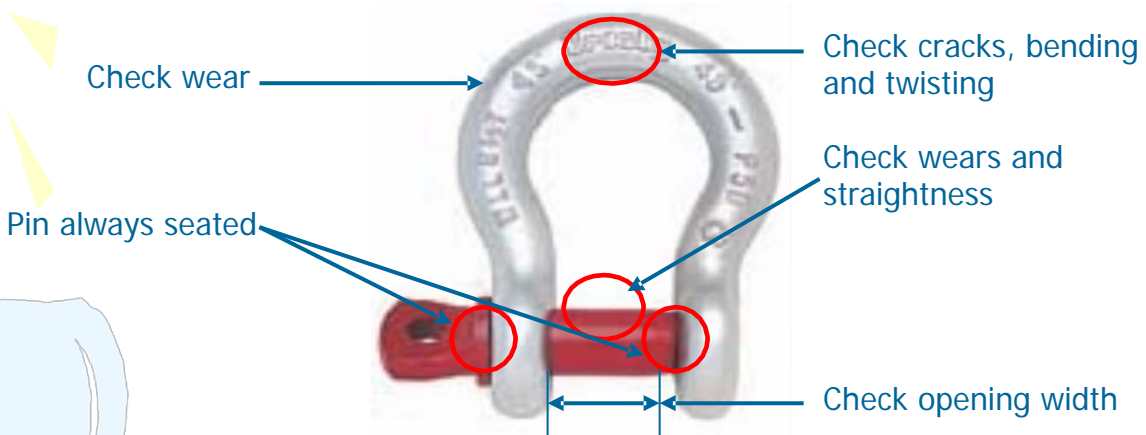

Fig. 9

- **Check and Recommend for Replacement if found any one of the following:**

- ☐ Wear of pin and body higher than 8% diameter
- ☐ Nicks, cracks and gouges in stressed areas
- ☐ Distortion in any axis
- ☐ Misalignment of untapped/tapped hole
- ☐ Excessive wear of untapped hole
- ☐ Incorrect pin inserted. Pin not running free
- ☐ Pin screwed, less than outside face flush
- ☐ Head of pin not bearing on shoulder of untapped hole
- ☐ Thread damage or excessive wear
- ☐ Excessive corrosion
- ☐ Repairs by welding
- ☐ Missing locking devices (cotter pin), if applicable

10. SHACKLES

10.4. APPLICATION/RIGGING METHOD:

- ⌚ Shackles symmetrically loaded with two leg slings having a maximum included angle of 120° can be loaded to Rated Capacity.
- ⌚ Use bolt-type and Screw Pin Bow Shackles only.
- ⌚ Riggers do not exceed 120° included angle. (see Fig. 10)

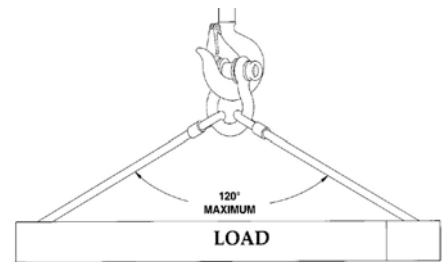

Fig. 10

- ⌚ Always put the pin on the top of the hook, otherwise Shackle spread and sling eyes can be damaged. (see fig. 11 & 12)

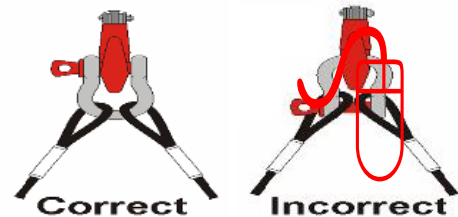

Fig. 11

Fig. 12

- ⌚ Shackle pin can not turn. (see correct Fig. 13)



Fig. 13
Correct

- ⌚ Shackle pin bearing on running line can work loose. If the load shifts, the sling will unscrew the shackle pin. (see Fig. 14 & 15)

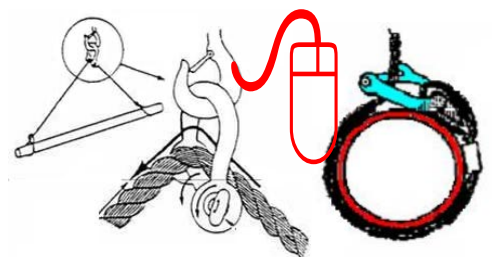

Fig. 14
Incorrect

Fig. 15

- ⌚ Never replace a shackle pin with ordinary bolt. The strength of an ordinary bolt is less than that of a shackle pin. (see Fig.16)

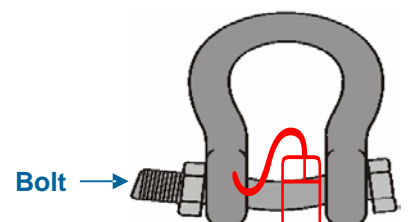

Fig. 16

10. SHACKLES

10.4. APPLICATION/RIGGING METHOD: (cont.)

Good Practice

- ⌚ Washers can be used to take up the space between the shackle and hook. (see Fig. 17)

Bad Practice

- ⌚ Never Allow shackle to be Pulled at an Angle, the legs will open up. (see Fig. 18)

ALWAYS:

- ⌚ Store and handle shackles correctly.
- ⌚ Inspect shackles before use and before placing into storage.
- ⌚ Select the correct pattern of shackle and pin for the application.
- ⌚ Allow for the full resultant imposed load.
- ⌚ Tighten the screw pin by hand only.
- ⌚ Ensure the load acts through the center line of the shackle using spacers if necessary to meet this requirement.

NEVER:

- ⌚ Use shackles with bent pins or deformed bodies.
- ⌚ Force, hammer or wedge shackles into position.
- ⌚ Eccentrically load shackles.
- ⌚ Replace the pin with a bolt.
- ⌚ Fit pins in contact with moving parts which may loosen or unscrew them.
- ⌚ Shock load shackles.
- ⌚ Use shackle across direction it will reduced 50% SWL

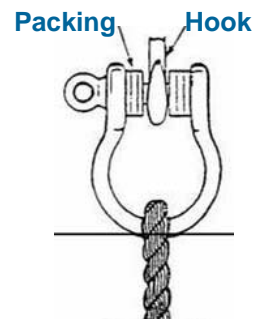

Fig. 17

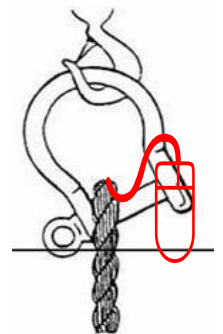





Fig. 18

11. PLATE CLAMPS

11.1. TYPE:

VERTICAL LIFTING LOCKING	HORIZONTAL LIFTING NON-LOCKING	LOCKING SCREW
 <p data-bbox="298 866 371 901">Fig. 1</p>	 <p data-bbox="706 866 778 901">Fig. 2</p>	 <p data-bbox="1084 866 1157 901">Fig. 3</p>

11.2. IDENTIFICATION:

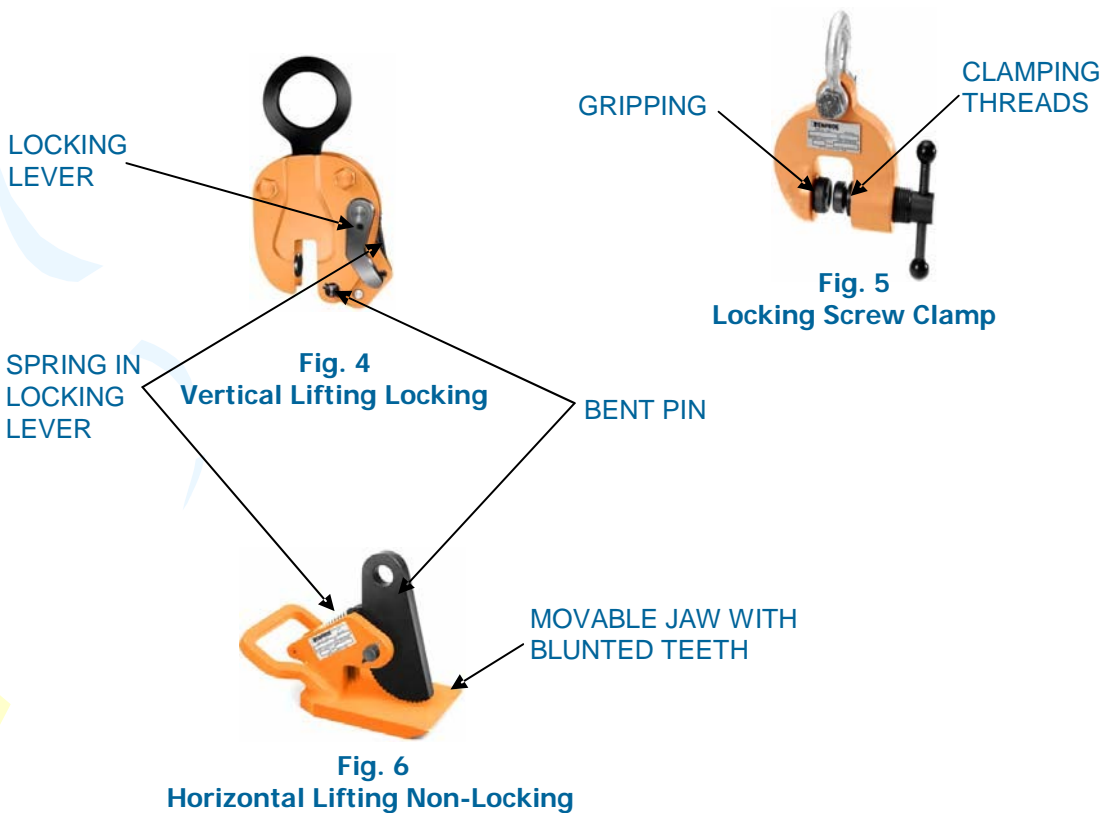

11. PLATE CLAMPS

11.3. INSPECTION:

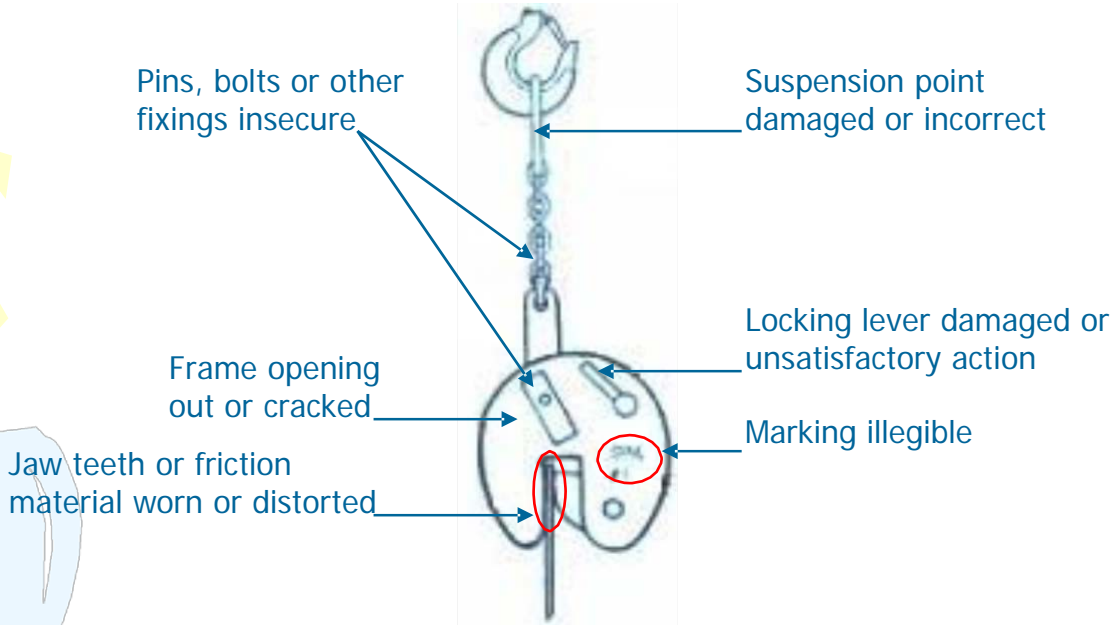

Fig. 7

Vertical and Universal Plate Clamp Inspection Points

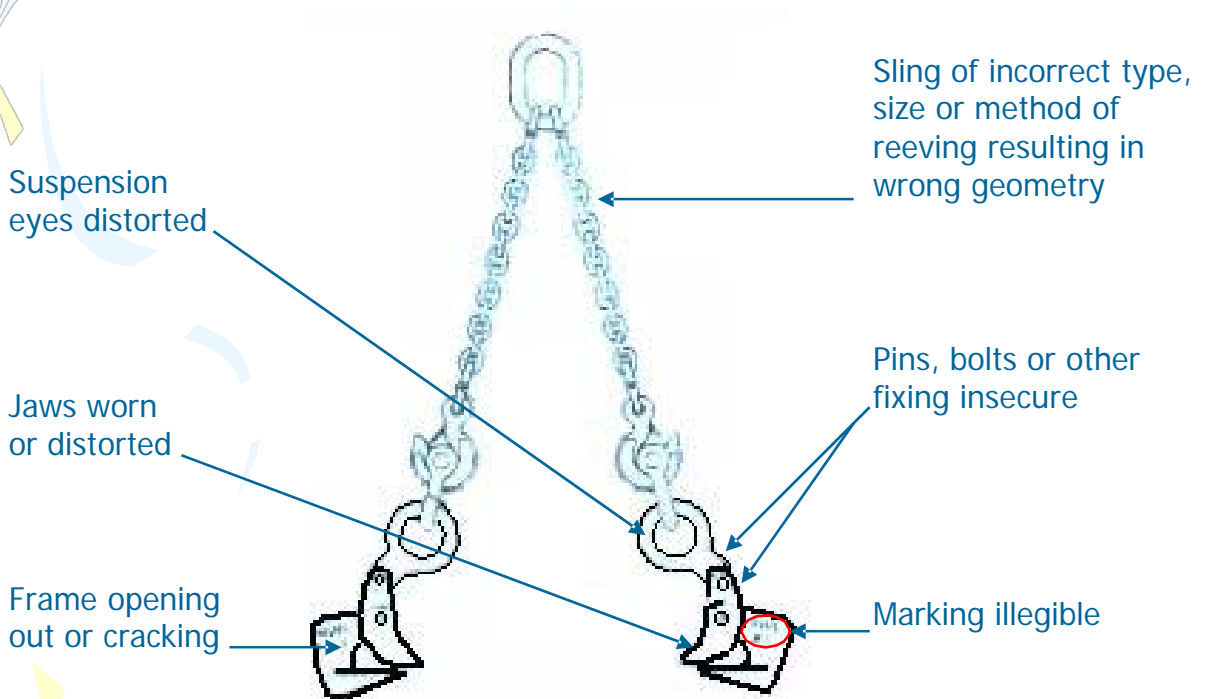

Fig. 8

Horizontal Plate Clamp Inspection Points

11. PLATE CLAMPS

11.3. INSPECTION: (cont.)

Friction Lifting Type

Remove from service if found any of the following conditions:

- Wear, damage or distortion to fixed and moving jaws
- Frame opening out or cracked
- Insecure, worn or bent pins, bolts etc.
- Worn friction grip material
- Nicks, cracks, gouges
- Excessive corrosion
- Damaged, bent or unsatisfactory acting locking lever
- Improper action of locking lever
- Tight, bent, damaged clamping threads
- Blunted teeth in fixed, movable jaws – see Manufacturer recommendations
- Worn out, bent pins

Horizontal Lifting Type

Remove from service if found any of the following conditions:

- Distortion of frame
- Wear on gripping surfaces
- Nicks, cracks, gouges
- Excessive corrosion
- Blunted teeth in fixed, movable jaws – see Manufacturer recommendations
- Worn out, bent pins

11. PLATE CLAMPS

11.4. APPLICATION/RIGGING METHOD:

Vertical plate Clamp (Universal Type)

⌚ Locked open for easy placement and removal



Fig. 9

⌚ Locked closed for lifting



Fig. 10

Horizontal Type

⌚ Plate Clamp in pairs





Fig. 11



Fig. 12

12. HOOKS

12.1. TYPE:

EYE SLING HOOK	CLEVIS SLING HOOK WITH LATCH	PIPE HOOK
 Fig. 1	 Fig. 2	 Fig. 3
Not to be used for pipe lifting		

12.2. IDENTIFICATION:

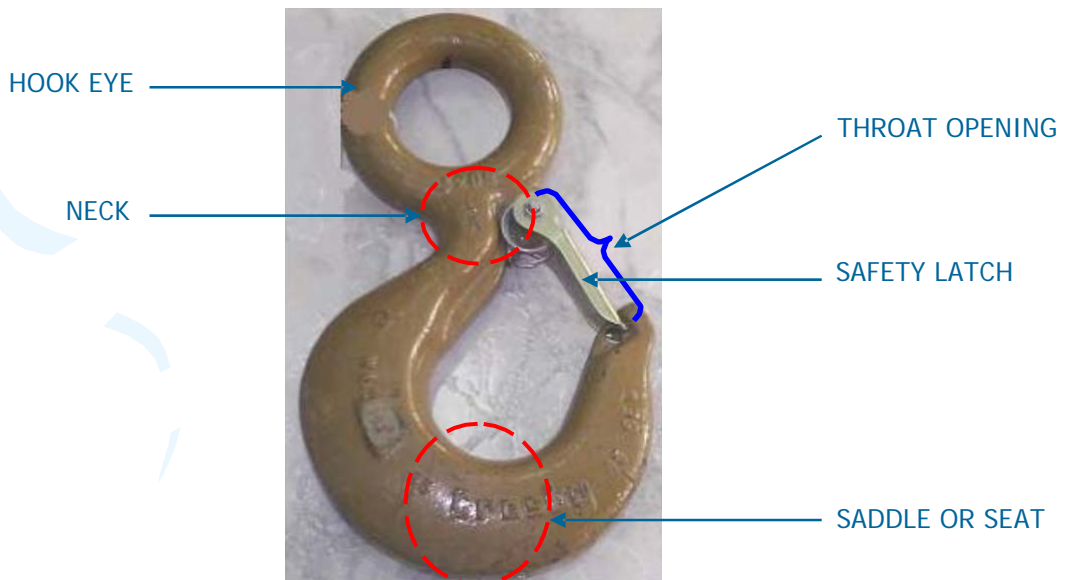

Fig. 4

12. HOOKS

12.3. INSPECTION:

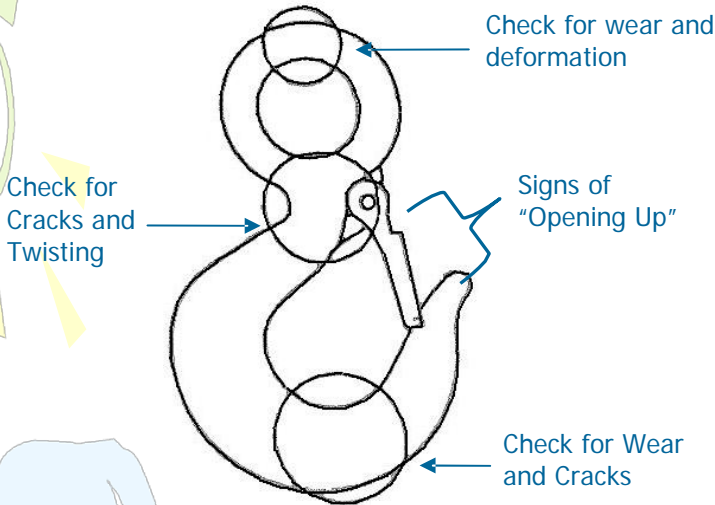

Fig. 5

Check the hook for the following:



10°
Eye
Twist

Fig. 6



10°
Eye
Bend

Fig. 7



10°
Hook
Twist

Fig. 8



10°
Hook
Bend

Fig. 9

Remove hook from service if any of the following conditions has been found:

- ③ Throat opening higher than 15% original throat
- ③ Lateral twist higher than 10 degrees
- ③ Wear in eye and saddle higher than 8% of original thickness
- ③ Cracks, nicks, scores, gall marks in body
- ③ Misalignment of shank, excessive wear
- ③ Thread damage or excessive wear
- ③ Repair by welding
- ③ Excessive wear, damage to cross head pin
- ③ Damaged or missing locking devices
- ③ No free running of swivel. Bearing damage, if applicable
- ③ Cracks, defects in trunnion weld joint, if applicable
- ③ Loose bolts, nuts, pins
- ③ Damaged or missing safety catches, if applicable
- ③ Lack of lubrication



Wear
HOOK EYE
DAMAGE

Fig. 10



Elongation

Fig. 11



MODIFICATION NOT
ALLOWED

Fig. 12

12. HOOKS

12.4. APPLICATION/RIGGING METHOD :

Correct Use of an Eye Hook:

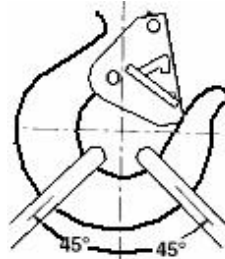

Fig. 13

When placing two slings on the hook, the sling angle measured from the horizontal shall be equal to or greater than 45°. For sling angles less than 45°, a master link, pear link, bolt-type shackle, or screw pin shackle should be used to attach the slings to the hook.

Note:

1. Forged swivels and swivel hooks with bronze bushings are to be used for positioning prior to lifting a load. DO NOT rotate under load.
2. DO NOT overcrowd the hook.
3. DO NOT swivel the hook while it is supporting a load.

Incorrect Use of an Eye Hook:

 Side Load.

 Back Load.

 Tip Load.

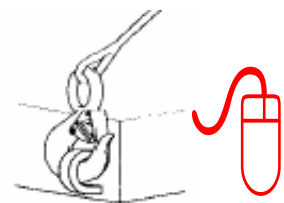

Fig. 16

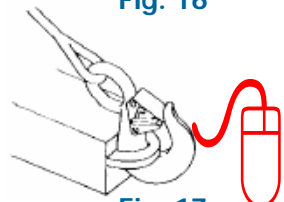

Fig. 17

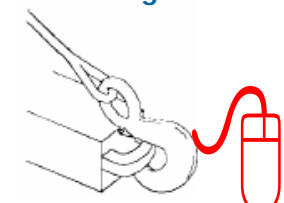

Fig. 18

13. EYEBOLTS

13.1. TYPE & IDENTIFICATION:

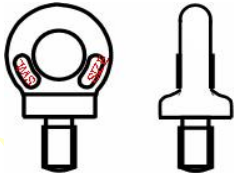

Fig. 1
COLLAR EYE BOLT

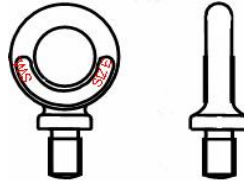

Fig. 2
DYNAMO EYE BOLT

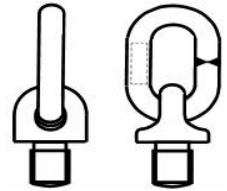

Fig. 3
EYE BOLT WITH LINK

13.2. INSPECTION:

Remove eyebolt from service if any of the following conditions has been found:

- ③ Wear in eye and link, if any, higher than 8% diameter
- ③ Nicks, cracks and gouges in shank and eye
- ③ Nicks, cracks and gouges in shank to collar junction
- ③ Distortion in any axis
- ③ Thread damage or excessive wear
- ③ Excessive corrosion
- ③ Any type of repair
- ③ Cleanliness of thread, underside of collar
- ③ Illegible markings

13.3. APPLICATION/RIGGING METHOD:

☞ Lifting With Eye Bolts (see fig. 4)

Never run a sling through a pair of eye bolts as shown:

- 🕒 The loads in this fitting result in an effective load at a much more severe angle.
- 🕒 The load P to Q and the loads in A and B combine to give C.
- 🕒 Use a pair of shackles instead.

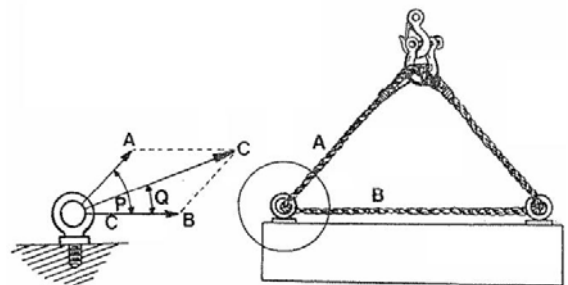

Fig. 4

13. EYEBOLTS

13.3. APPLICATION/RIGGING METHOD: (cont.)

Correct for shoulder Type Eye and Ring Bolts providing loads are reduced to account for angular loading.

More than one eye bolt diameter of threads, only (1) nut required. (see Fig. 5)

Tighten hexagonal nut securely against load. (see Fig. 6)

One eye bolt diameter of threads or less, use two (2) nuts. (see Fig. 7)

Tighten hexagon head nut securely against load. (see Fig. 8)

One eye bolt diameter or less. (see Fig. 9)

After slings have been properly attached to the eye bolts, apply force slowly. Watch the load carefully and be prepared to stop applying force if the load starts buckling.

Buckling may occur if the load is not stiff enough to resist the compressive forces which result from the angular loading. (see Fig. 10)

NOTE:

If used a dynamo eyebolt in pairs a lifting beam must be used to ensure a vertical lift.

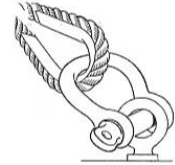

Fig.5

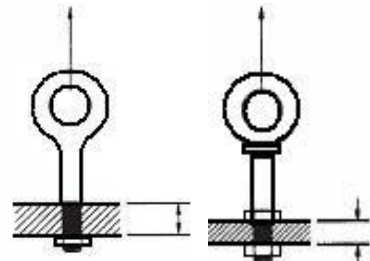

Fig.6
Correct

Fig.7
Correct

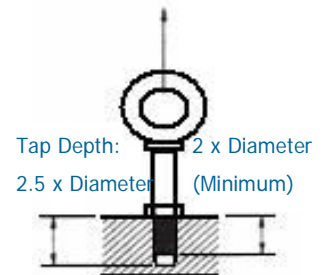

Fig.8
Correct

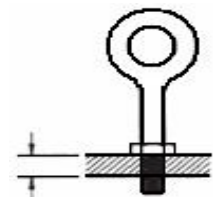

Fig. 9
Wrong

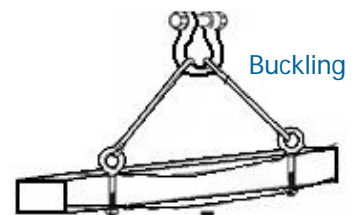

Fig. 10
Wrong

13. EYEBOLTS

13.3. APPLICATION/RIGGING METHOD: (cont.)

If the eye bolt protrudes so far through the load that the nut cannot be tightened securely against the load, use properly sized washers to take up the excess space between the Nut and the Load.

Thickness of spacers must exceed this distance between the bottom of the load and the last thread of the eye bolt.

Place washers or spacers between nut and load so that when the nut is tightened securely, the shoulder is secured flush against the load surface.

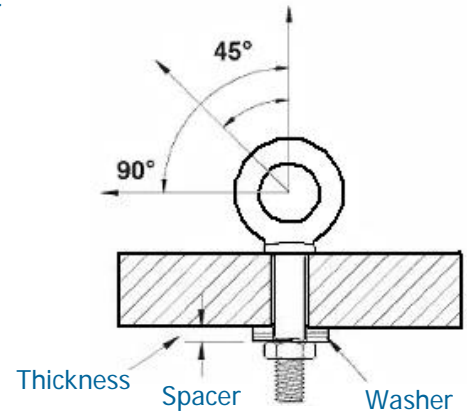

Fig. 11

ALWAYS:

- Store and handle eyebolts correctly.
- Inspect eyebolts before use and before placing into storage.
- Select the correct pattern eyebolt for the application.
- Ensure that the eyebolt and tapped hole threads are compatible and strong enough for the load.
- Correctly align the plane of the eye using shims where necessary.
- Ensure that the collar is fully seated when hand tight.

NEVER:

- Use Tommy bars, grips or wrenches to tighten eyebolts.
- Use dynamo eyebolts for angular loading.
- Use a single eyebolt to lift a load that is free to rotate.
- Reeve slings through the eyes, links or shackles fitted to pairs of eyebolts.
- Force hooks or other fittings into the eye; they must fit freely.
- Shock load eyebolts.

14. TURNBUCKLES

14.1. TYPES OF RIGGING SCREW:



Fig. 1
Hook to Hook Type



Fig. 2
Hook to Eye Type



Fig. 3
Eye to Eye Type



Fig. 4
Jaw to Eye Type



Fig. 5
Jaw to Jaw Type

14.2. INSPECTION:

Check and Recommend for Replacement if Found any one of the following:

- ☐ Cracks and bends.
- ☐ Damage and bent rods
- ☐ Check thread damage and thread engaged to full length of threaded body.
- ☐ Deformation
- ☐ Severe Corrosion

14.3. APPLICATION/METHOD:

- 🕒 Only rigging screws and turnbuckles that are marked with the appropriate safe working load after proof loading shall be used for lifting applications.
- 🕒 Securing Turnbuckles – twisting of the turnbuckle might occur, use a lock wire to prevent rotation of the turnbuckle. (see fig. 6)
- 🕒 The use of locknuts or mousing is an effective method of preventing turnbuckles from rotating.

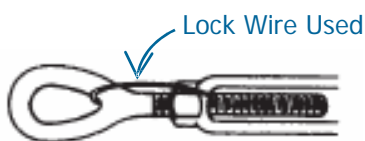

Fig. 6
Correct



Fig. 7
Incorrect
(No Lock Wire)

15. LIFTING BEAM

15.1. APPLICATION REQUIREMENTS TO:

- ⌚ Reduce headroom
- ⌚ Provide multiple lift points
- ⌚ Provide adjustable lifting centers
- ⌚ Handle out of balance loads
- ⌚ Remove or control inward or crushing forces
- ⌚ Allow for special load attachments

15.2. ACCESSORIES AND ATTACHMENTS:

- ⌚ Slings
- ⌚ Grabs
- ⌚ Shackles
- ⌚ Hooks
- ⌚ Etc.

15.3. THOROUGH EXAMINATION:

- ⌚ Beam distorted
- ⌚ Damaged or corroded
- ⌚ Worn, loose or missing bolts
- ⌚ Cracked welds
- ⌚ Attachment points worn, damaged or distorted, holes and eyes worn or elongated
- ⌚ Any other visible defects.

15.4. APPLICATION/METHOD:

- ⌚ The weight of the beam, together with its attachments, must be added to the weight of the load when calculating that total load that will be imposed on the crane hook.
- ⌚ Use tag lines to control long loads.

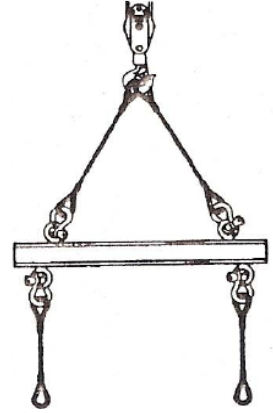

Fig 1
Lifting Beam

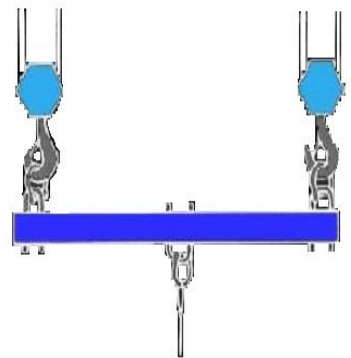

Fig. 2
Equalizer Beam

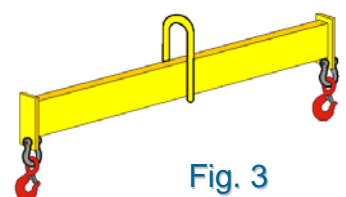

Fig. 3
Rigid Beam



15. LIFTING BEAM

15.4. APPLICATION/METHOD: (cont.)

ALWAYS:

- 🕒 Store and handle lifting beam correctly.
- 🕒 Refer to the safe use instructions for slings and attachments used with the beam.
- 🕒 Include the self weight of the beam and attachments when calculating the load imposed on the crane hook.
- 🕒 Ensure the load will remain stable when lifted.
- 🕒 Ensure that no one lifting point becomes overloaded by the slinging or handling methods.
- 🕒 Use tag lines to control long loads.

NEVER:

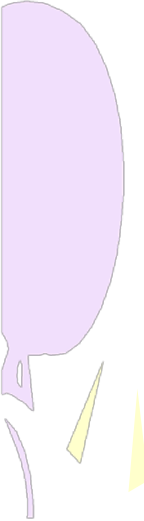
- 🕒 Use lifting beams to handle Loads other than those for which they are designed.
 - 🕒 Fit lifting beams to a hook other than those for which they are designed.
 - 🕒 Use damaged or distorted lifting beams and attachments.
 - 🕒 Unevenly load lifting beams.
 - 🕒 Allow lifting beams to foul any part of the crane or any other obstructions in the area.
- 
- 

16. BEAM CLAMP

16.1. TYPE:

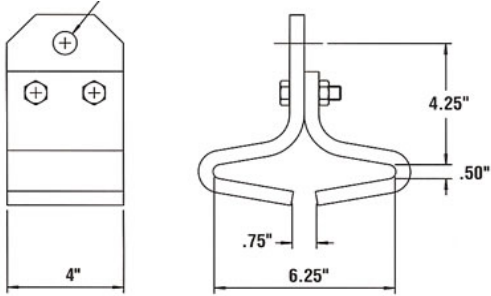

Fig. 1

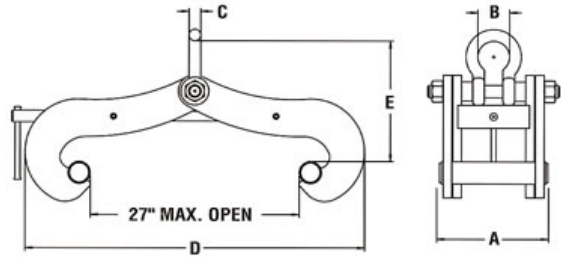

Fig. 2

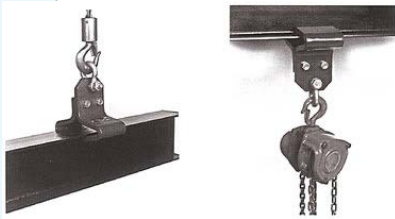

Fig. 3
FIXED BEAM CLAMP

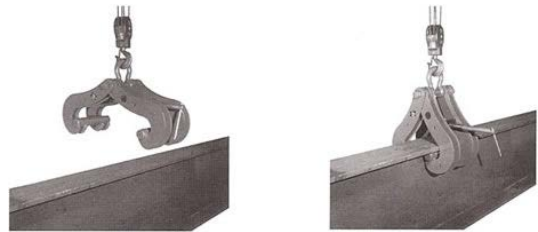

Fig. 4
ADJUSTABLE BEAM CLAMP

16.2. IDENTIFICATION:

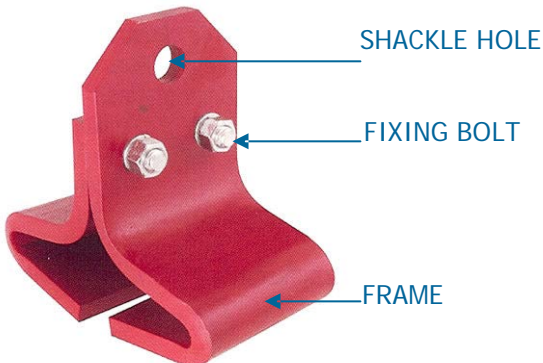

Fig. 5
FIXED BEAM CLAMP

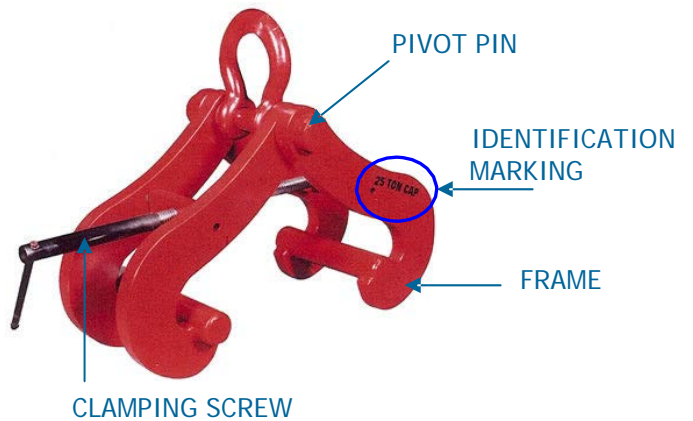

Fig. 6
ADJUSTABLE BEAM CLAMP

16. BEAM CLAMP

16.3. INSPECTION:

- ☐ Check identification/location and SWL is clearly marked. Then compare these markings against the current certificate.
- ☐ Check all moving parts against seizure, e.g. pivots, pins and load bar. Where swivel jaws are fitted, ensure that they are free to rotate.
- ☐ Check operation of unit and alignment of frame.
- ☐ Check bar handle is not dangerous to the operator's hand.
- ☐ Examine stress points for cracks, distortion, nicks, gouging and corrosion.
- ☐ Examine load bearing parts for signs of wear. Maximum permissible wear must not exceed 8% of bearing cross-section.
- ☐ Check the suspension points, shackle, pivot/pins, bolts & nuts, threads, load bar, jaws/grips and surfaces.
- ☐ Check the beam size.

16.4. APPLICATION:

ALWAYS:

- 🕒 Store and handle beam clamps correctly.
- 🕒 Inspect beam clamps and accessories before use and before placing into storage.
- 🕒 Ensure the supporting structure is adequate for the full load that will be imposed and suitable for the application.
- 🕒 Check the clamp is of the correct profile and size, or correctly adjusted, for the beam width and that it seats correctly on the beam flange.
- 🕒 Ensure the beam clamp is strong enough for the full load that will be imposed.
- 🕒 Check that the clamp is directly over the center of gravity of the load.



16. BEAM CLAMP

16.4. APPLICATION: (cont.)

NEVER:

- 🕒 Use beam clamps which are unidentified or uncertified for lifting applications.
- 🕒 Replace bolts, shackles etc without consulting the supplier.
- 🕒 Throw or drop beam clamps
- 🕒 Use beam clamps on damaged or distorted beams.
- 🕒 Force or wedge hooks of lifting appliances into the attachment eye or lifting (e.g. Shackle)
- 🕒 Obliquely load beam clamps without the authority of the supplier.

STORING AND HANDLING BEAM CLAMPS:

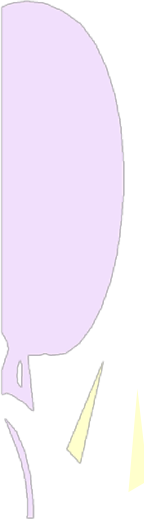
- 🕒 Never return damaged beam clamps to storage. They should be dry, clean and protected from corrosion. Where necessary fasteners should be reassembled immediately after removal from the beam.
- 
- 

17. LIFTING APPLIANCE

17.1. HAND-OPERATED CHAIN BLOCK

17.1.1. TYPES:



Fig. 1
HEAVY DUTY



Fig. 2
STANDARD DUTY

17.1.2. IDENTIFICATION:



Fig. 3

17. LIFTING APPLIANCE

17.1. HAND-OPERATED CHAIN BLOCK (cont.)

17.1.3. INSPECTION:

- ⇒ Keep the chain block clean and regularly lubricate the load chain and both hook shanks.
- ⇒ Carry out a visual inspection every time the chain block is used and listen for any unusual sounds during operation.
- ⇒ Depending upon the frequency of use and local conditions the load chain will eventually show signs of wear, at which point it should be replaced.
- ⇒ Overloading or incorrect hooking may distort the hook and increase the hook opening. If this occurs replace the hook immediately.
- ⇒ The components shall be free from deformation, cracks, flaws or other defects and there shall be no loosening of connections.
- ⇒ When the hand chain is released at any point during raising and lowering, the brake shall hold the weight of the load
- ⇒ The block shall be free from deformation, cracks, flaws or other defects, there shall be no loosening of connections and the block shall operate satisfactorily.
- ⇒ On removal of the restraining pin, the brake shall immediately engage and prevent the load from descending.

SPROCKET
DAMAGED



Fig. 4

SAFETY LATCH
DAMAGED



Fig. 5

SAFETY LATCH
MISSING



NO NAME
PLATE DETAILS

Fig. 6

WARNING!

- ③ The chain block should be disassembled, cleaned, inspected, reassembled and tested by an Authorized Service Agent annually, or more frequently if used outside, exposed to the weather.
- ③ The load chain and the hooks are manufactured from special alloy steels and precisely heat treated. DO NOT weld or re-heat treat.

17. LIFTING APPLIANCE

17.1. HAND-OPERATED CHAIN BLOCK (cont.)

17.1.4. APPLICATION/METHOD:

Hand Chain Blocks – are available in range capacity and with various types of suspension. Select the block to be used and plan the lift taking the following into account:

- ⌚ Type of suspension – hook, trolley etc.
- ⌚ Capacity, class of use and range of lift.
- ⌚ Chain blocks are designed for vertical lifting only.

ALWAYS:

- ⌚ Store and handle chain blocks correctly.
- ⌚ Inspect chain blocks and accessories before use and before placing into storage.
- ⌚ For top hook suspension, use hooks that are fitted with safety catches, or mouse the hook, ensuring the support fits freely into the seat of the hook.
- ⌚ For trolley suspension ensure the trolley is correctly set for the beam width.
- ⌚ Check that the bottom hook will reach its lowest point without running the chain fully out.
- ⌚ Adopt safe slinging practices and follow the instructions for the safe use of the equipment used.

NEVER:

- ⌚ Expose chain blocks to chemicals, particularly acids, without consulting the manufacturer.
- ⌚ Replace the load chain with a longer one without consulting the manufacturer.
- ⌚ Use undue effort to force the block to operate.
- ⌚ Throw, drop or drag a chain block.
- ⌚ Allow oil or grease to come into contact with the brake.
- ⌚ Expose a chain block directly to the elements, water spray, steam etc without consulting the manufacturer.

17. LIFTING APPLIANCE

17.1. HAND-OPERATED CHAIN BLOCK (cont.)

17.1.5. SAFETY INSTRUCTION:

ENSURE

- ⌚ That the chain block is in sound condition and good working order. Take action for immediate repair or replacement of damaged parts.
- ⌚ The support for the chain block is capable of withstanding a load of at least 1½ times the chain block safe working load.
- ⌚ All non-essential persons keep a safe distance whilst the chain block is in use.
- ⌚ Load slings are fully engaged in load hook and that hook safety latch is in the closed position.

KEEP

- ⌚ The chain block clean for the best and safest performance.
- ⌚ Work area clean and tidy and free from unrelated materials.

LOCATE the chain block in a suitable, well lit work area.

RAISE AND LOWER in a smooth, controlled manner and DO NOT shock load the chain block by allowing the attached load to fall freely, even for very short distances.

CHECK the brake operation by stopping when the load has been raised a short distance (100mm) and ensuring that it is held with no downward creep.

USE a qualified person to lubricate and maintain the chain block.

STORE chain block in a dry, cool area when not in use.

DO NOT

- ⌚ Operate the chain block if damaged.
- ⌚ Allow untrained persons to operate the chain block.
- ⌚ Exceed the rated capacity (safe working load) of the chain block.
- ⌚ Raise or lower the load with jerky or abrupt movements of the hand chain.
- ⌚ Attempt to lift a load if the load chain is kinked or knotted.
- ⌚ Try to raise a load with two, or more, chain blocks - use a single block of adequate capacity.
- ⌚ Use the chain block to drag the load across the floor. Always position the load directly below the block.
- ⌚ Wrap the load chain around the load - always use separate, suitable, slings/chains/ropes of the correct capacity.
- ⌚ Allow anyone to stand or pass beneath the raised load.
- ⌚ Use the chain block for purposes other than that for which it is intended.



DANGER! Use the chain block for lifting only, NOT for supporting the lifted load.

17. LIFTING APPLIANCE

17.1.6. INSPECTION:

☞ Hand Chain

Check For:

- ☐ Cracks, distortion, wear or corrosion.
- ☐ Cracks, distortion, wear of hand chain wheel.
- ☐ Incorrect seating in hand chain wheel.
- ☐ Rusty chain.

☞ Load chain:

Check For:

- ☐ Cracks, distortion, wear of blocks, wear, slackness of sheave wheel
- ☐ Incorrect seating in sprocket wheel.
- ☐ Damage to slack end or load end anchor
- ☐ Rusty chain
- ☐ Twisted chain in multiple fall

17.2. CHAIN LEVER HOIST

17.2.1. IDENTIFICATION:

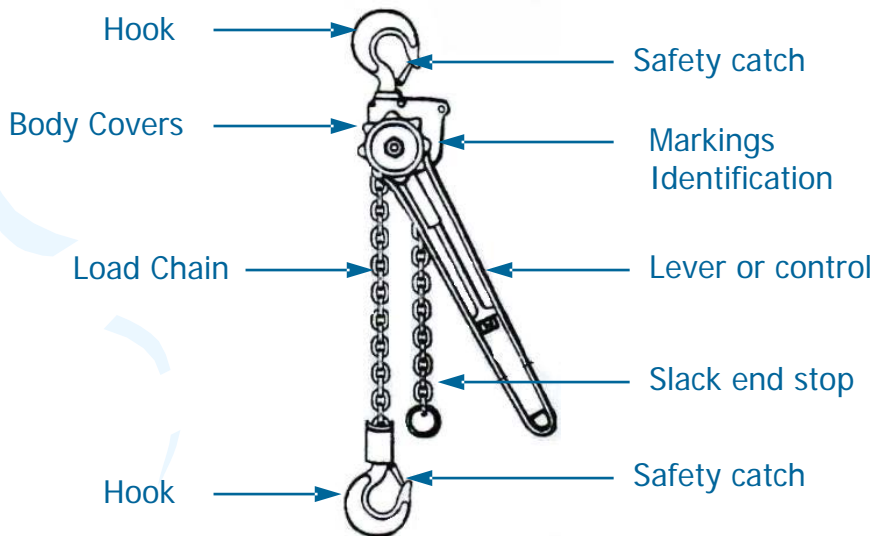

Fig. 7

☞ HOOKS, TERMINAL FITTINGS

Check for:

- ☐ Cracks, distortion or wear of blocks. Wear, slackness of sheave wheel

17. LIFTING APPLIANCE

17.2.2. INSPECTION: (cont.)

MAIN FRAME

Check For:

- ☐ Cracks, distortion or worn in body, gear covers or chain guides.
- ☐ Loose nuts, bolts, rivets, or pins. Thread damage or wear. Missing locking devices.
- ☐ Corrosion, wear or damage to pawl, ratchet or spring.
- ☐ Cracks or uneven wear of pinions, gear wheels or bearings.
- ☐ Wear, damage to brakes, chain stripper.
- ☐ Improper electrical condition, if applicable.

REPAIR:

Check For:

- ☐ Repair not in accordance with manufacturers recommendations.
- ☐ Replaced parts incorrectly assembled.
- ☐ Replaced parts not manufacturer certified.

OPERATIONAL TEST:

Check For:

- ☐ Undue effort, excessive noise or jumping of chains during hoisting/lowering.
- ☐ Malfunction of pawl, operating spring and ratchet.
- ☐ Incorrect action of chain guides.
- ☐ Brake operation. Must be kept free of oil, grease etc.

17. LIFTING APPLIANCE

17.2.3. APPLICATION/METHOD:

ALWAYS:

- ⌚ Store and handle lever hoist correctly.
- ⌚ Inspect lever hoists and accessories before use and before placing into storage.
- ⌚ Ensure any support fits freely into the seat of the hook and does not exert a side thrust on the point.
- ⌚ Check the operation of the brake.
- ⌚ Check that the bottom hook will reach its lowest point without running the chain against the stop.
- ⌚ Adopt safe slinging practices and follow the instructions for the safe use of the equipment used.

NEVER:

- ⌚ Expose lever hoists to chemicals, particularly acids, without consulting the manufacturer.
- ⌚ Replace the load chain with a longer one without consulting the manufacturer.
- ⌚ Extend the lever or use undue effort to force the lever hoists to operate.
- ⌚ Throw, drop or drag a lever hoist.
- ⌚ Allow oil or grease to come into contact with the brake.
- ⌚ Expose a lever hoist directly to the elements, water spray, steam etc without consulting the manufacturer.

17. LIFTING APPLIANCE

17.3. WIRE ROPE GRIP/PULL LIFTING MACHINE

17.3.1. TYPE:

MATERIAL HOISTING CAPACITY

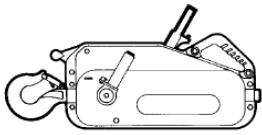

Fig. 8



Fig. 9

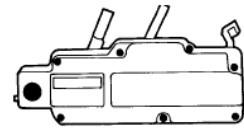

Fig. 10

17.3.2. IDENTIFICATION:

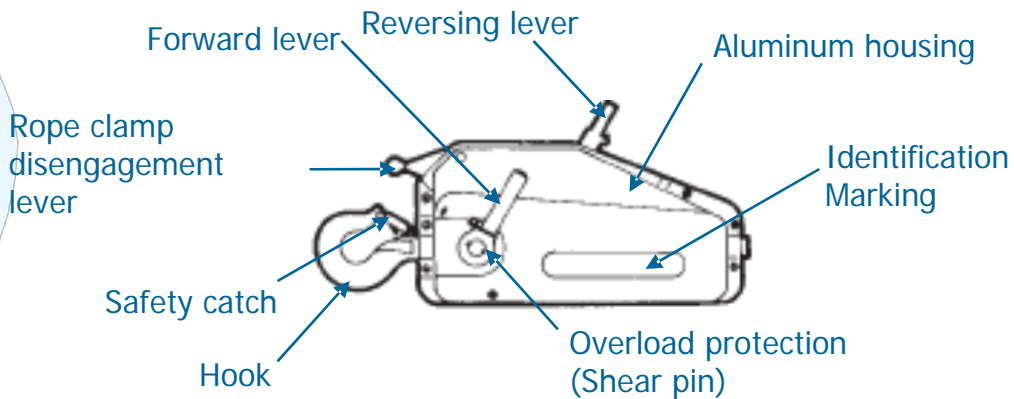

Fig. 11

17.3.3. APPLICATION/METHOD:

Rigging Arrangement

- ⌚ Diverters
- ⌚ Pulley Blocks
- ⌚ Anchorage and suspension points
- ⌚ Imposed loads

Storing and Handling

- ⌚ Never return damaged grip/ pull machines, ropes etc. to storage.
- ⌚ Grip/Pull machines should be dry, clean and protected from corrosion.
- ⌚ Rope should be carefully coiled onto a suitable drum or frame for storage, taking care to avoid any twists
- ⌚ Store machines and ropes on a suitable rack, not on the floor where they may be damaged.



17. LIFTING APPLIANCE

17.3. WIRE ROPE GRIP/PULL LIFTING MACHINE

17.3.3. APPLICATION/METHOD: (cont.)

ALWAYS:

- 
- ⌚ Store and handle grip/pull machine correctly.
 - ⌚ Inspect the machine, rope and accessories before use and before placing into storage.
 - ⌚ Ensure mounting and suspension points are secure and suitable for the full loads that will be imposed.
 - ⌚ Ensure the machine is free to align correctly with the rope and the rope is free of any obstructions.
 - ⌚ Use only the correct rope supplied for the machine.

NEVER:

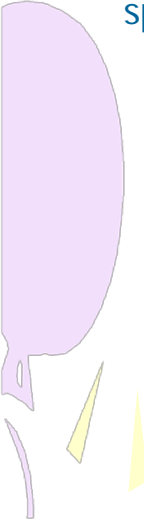
- 
- ⌚ Use kinked, damaged ropes or ropes with broken wires.
 - ⌚ Extend or force operating levers.
 - ⌚ Operate raising and lowering levers at the same time.
 - ⌚ Use grip/pull machines if the rope is twisted or trapped.
 - ⌚ Use grip/pull machine for man-riding applications unless they are specifically designed/adapted for that purpose.
- 

17. LIFTING APPLIANCE

17.4. FAMILIARIZATION OF CRANE OPERATION:

17.4.1. Basic Crane Configuration

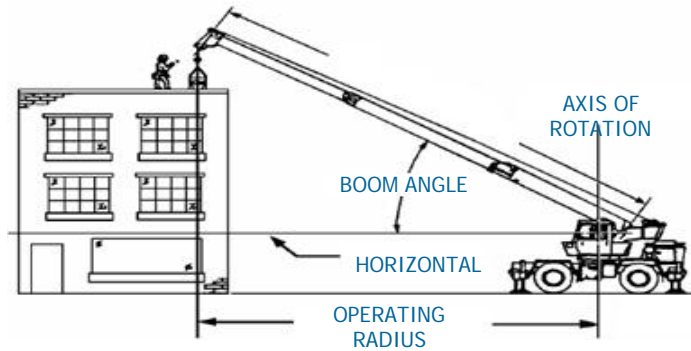

Fig. 12
Onshore Crane (Rough Terrain)

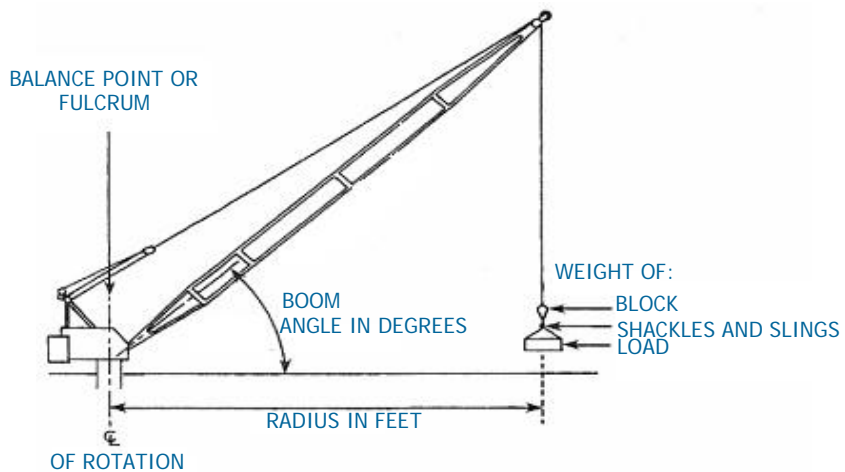

Fig. 13
Offshore Crane (Pedestal)

17.4.2. Basic Crane Functions: Lifting, Booming & Swinging

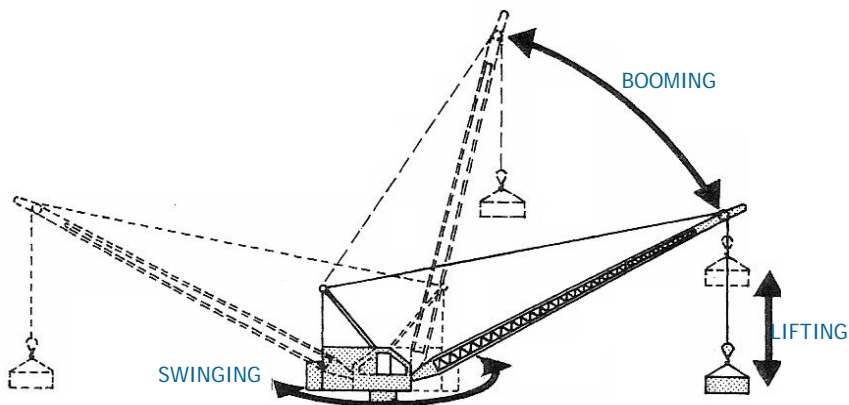

Fig. 14

17. LIFTING APPLIANCE

17.5. FAMILIARIZATION OF CRANE TYPES:

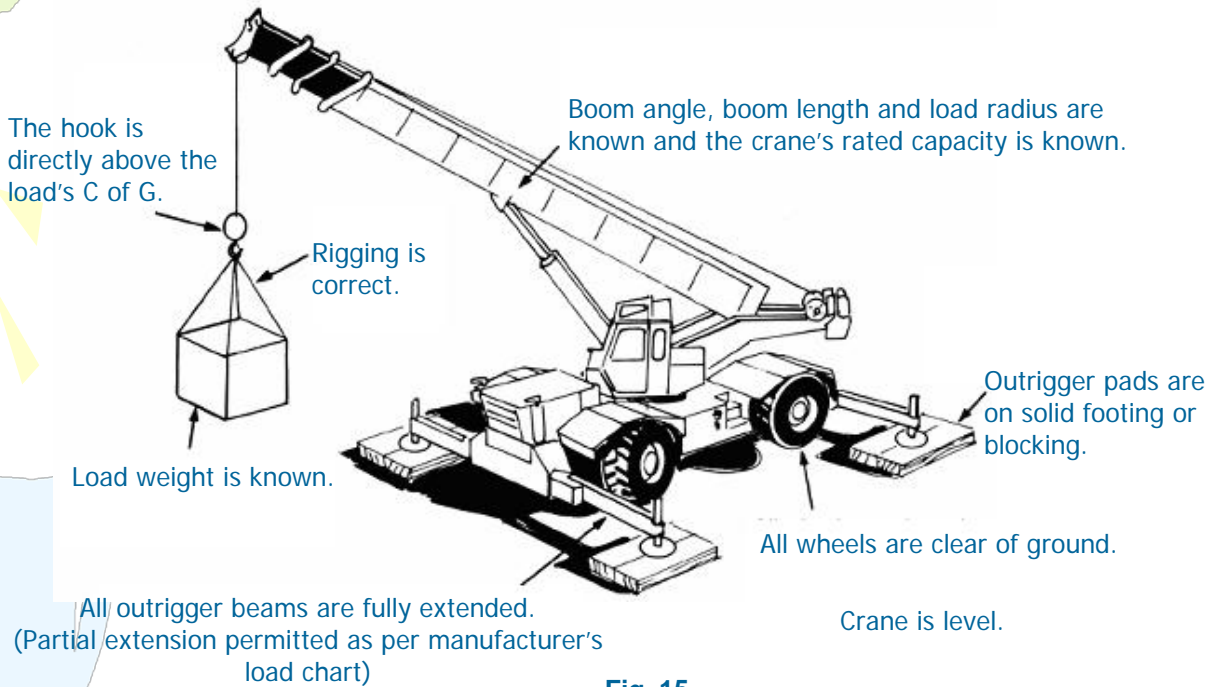

Fig. 15

17.5.1. Rough Terrain Crane

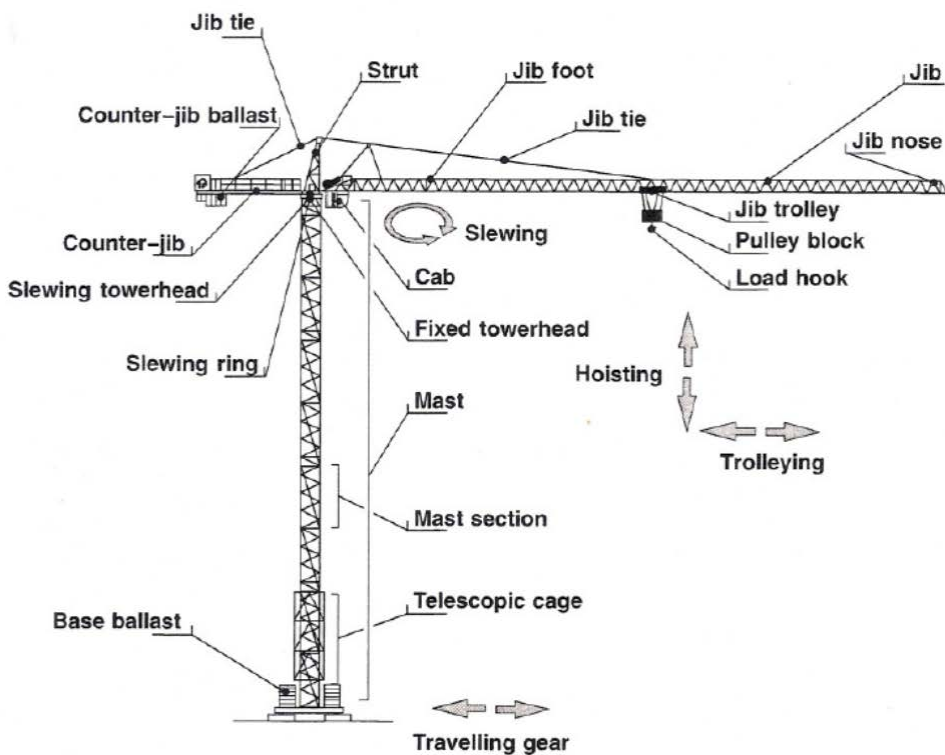

Fig. 17

17.5.2. Tower Crane

17. LIFTING APPLIANCE

17.5. FAMILIARIZATION OF CRANE TYPES: (Cont.)

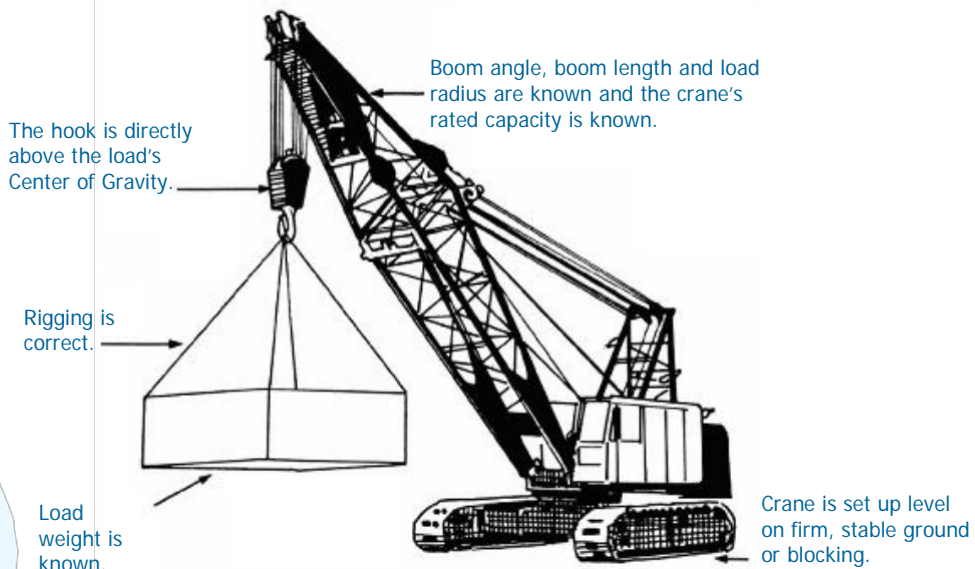

Fig. 18

17.5.3. Crawler Crane

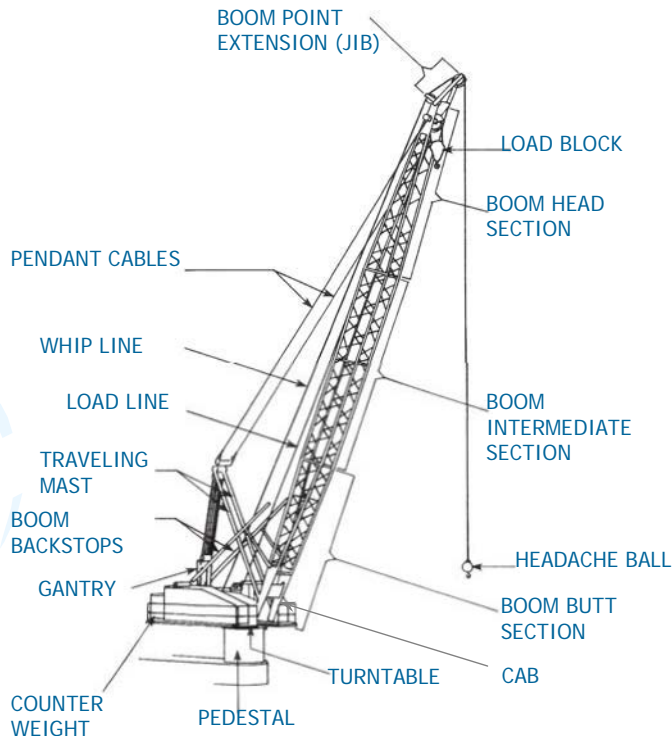

Fig. 19

17.5.4. Offshore Crane

18. LOAD

18.1. STANDARD SIGNS IDENTIFICATION

THIS SIDE UP

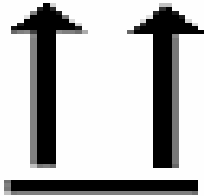

Fig. 1

AWAY FROM HEAT

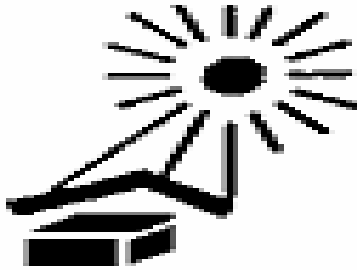

Fig. 2

THIS SIDE UP

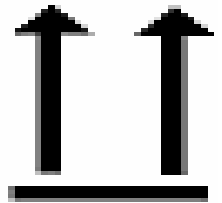

Fig. 3

AWAY FROM WATER



Fig. 4

CENTER OF GRAVITY

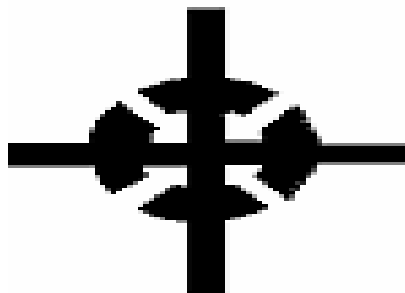

Fig. 5

NO HOOKS



Fig. 6

SLING HERE



Fig. 7

FRAGILE HANDLE WITH CARE



Fig. 8

SLING HERE



Fig. 9

18. LOAD

INSPECTION:

Check For:

- ☐ Data plate for standard of manufacture
- ☐ Certification date and make sure that there is at least 1 month certification remaining or to local regulation
- ☐ Capacity of the Cargo Carrying Units (CCU) and ensure its not overloaded
- ☐ Structure and general condition of CCU
- ☐ Condition of door locks and seals
- ☐ Heavier cargo is at the bottom
- ☐ Cargo is lashed down or wedged in place
- ☐ Door safety nets are fitted where possible
- ☐ Condition of slings and shackles
- ☐ Weight as manifested
- ☐ Drainage holes are clear, In open top units

ENSURE

- 🕒 Correct hazard labels are affixed if applicable
- 🕒 Old hazard labels are removed
- 🕒 Adequate packing between the items of freight
- 🕒 There are loose items on the roof of the CCU

MAKE sure there are no sharp items next to soft skinned drums

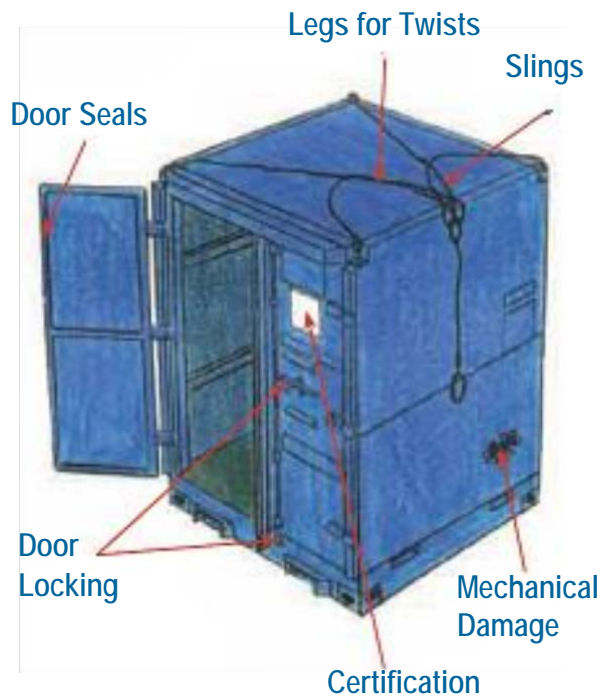

Fig. 10

18.2. CONTAINERS / CARGO BOXES

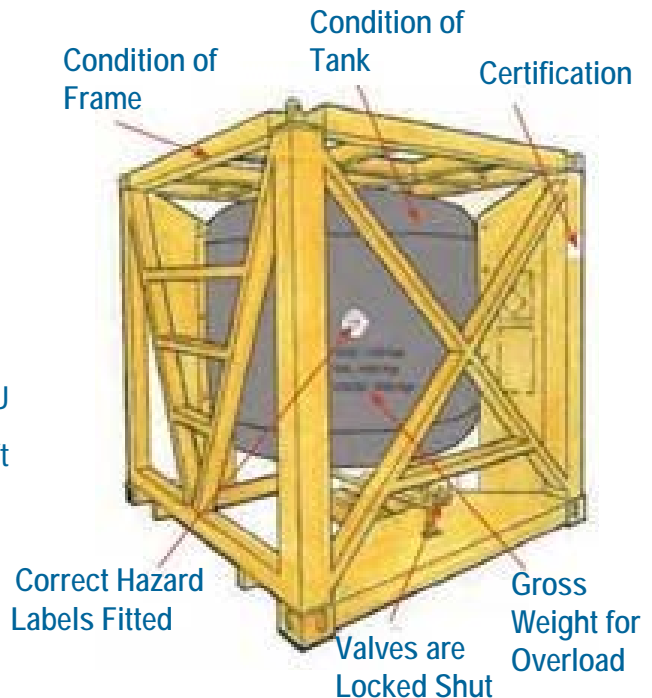

Fig. 11

18.3. FUEL / CHEMICAL TANKS

18. LOAD

18.4. GAS CYLINDER RACK

18.4.1. INSPECTION:

Securing

- ⌚ all Gas Cylinder racks should have a primary and secondary method of securing the cylinders for transit. (see Fig. 12)

Advisable

- ⌚ To have an increased factor of safety.



Fig. 12

18.5. MAN BASKETS

18.5.1. INSPECTION:

18.5.2. PERSONNEL:

- ⌚ In suspended baskets a distribution as symmetrical as possible of the load should be achieved.
- ⌚ Persons in suspended baskets should fasten their safety harness onto the anchorages provided.
- ⌚ The basket rated capacity should not be exceeded.
- ⌚ Tools and material carried by personnel should be secured, in particular against displacement, tipping, and falling out.
- ⌚ Occupants shall not stand on or work from the handrail or side protection of the suspended basket or anything in it.
- ⌚ The basket shall be positioned on a firm surface during access and egress.
- ⌚ Any power cables or hoses provided to the basket should be connected in such a way that they will not interfere with the safe operation of the basket.
- ⌚ Power cables or hoses shall not be used as guide ropes.
- ⌚ When electric welding from the basket, special care shall be taken to earth the basket in order to protect the crane and/or its ropes from becoming conductors of electricity.
- ⌚ All movements should proceed gently with low speeds.

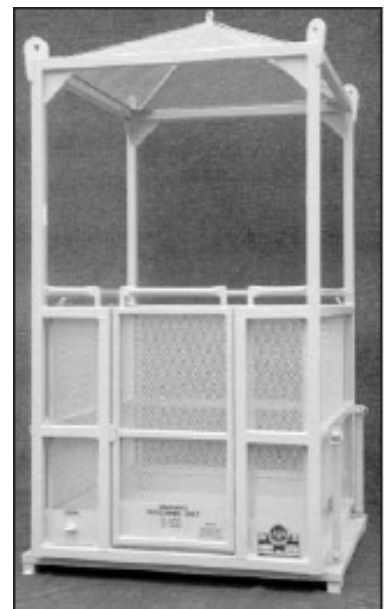

Fig. 13

18. LOAD

18.6. COMMON LOADS:

18.6.1. Concrete and Muck Skips

Concrete and muck skips should not be lifted directly by the crane hook. A single-leg sling (commonly known as a drop or skip chain) should be used, as moving a heavy crane hook precisely into place can be difficult. (see Fig. 14)



Fig. 14

18.6.2. Scaffold Tubes

When lifting bundles of tubes, bars or other loose materials, whether banded or not, slings should be double wrap choke hitch. SWL factor for slings used thus is 0.8 of SWL. (see Fig.15)

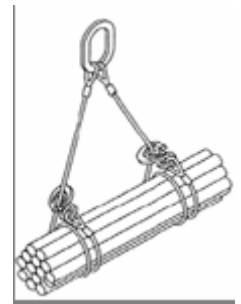

Fig. 15

18.6.3. Palletized loads

An example of a frequently lifted load that requires special equipment is a pallet of bricks, blocks etc requiring crane forks with safety netting. Note that the mesh size should be smaller than the smallest item to be lifted. (see Fig. 16)

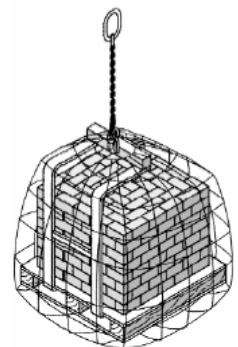

Fig. 16

18.6.4. Beams

Use double wrapped slings when sling legs can slide together. SWL factor for slings used thus is 0.8 of SWL. (see Fig. 17)

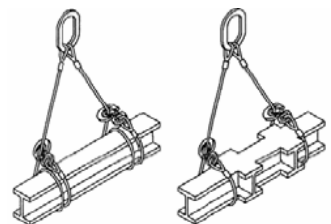

Fig. 17

18. LOAD

18.6.5. Stillages

Wrap slings round corner posts. Do not attempt to lift double stacked stillages. Beware of overloading scaffold boards if landing loaded stillages on a scaffold. SWL factor for chain slings used thus is 0.8 of SWL. (see Fig. 18)

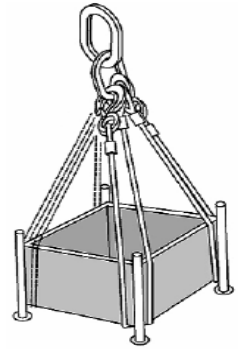

Fig. 18

18.6.6. Rubbish Skips

Typical arrangement of special sling, with steel box sections under skip, and steel tube spreaders to keep sling legs vertical. Keyhole plates on skip lugs are for location purposes, not for lifting. Skips with specially adapted lifting points are acceptable providing thorough examination is undertaken at 6 month intervals. Beware of rusted floors, they can fall out when the skip is lifted. (see Fig. 19)

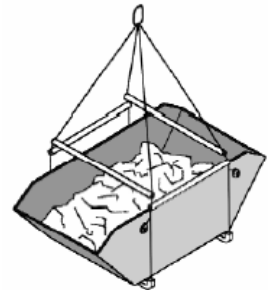

Fig. 19

18.6.7. Pipes

For short pipes, pass sling through pipe. SWL factor for webbing slings used thus is 1.4. (see Fig. 20)

For long pipes, use two slings in choke hitch, double wrapping if slings are likely to slide together. Provided that no angle exceeds 90° at Included angle, then use the SWL for one sling for the SWL of this arrangement. (see Fig. 21)



Fig. 20

③ **Note** that a shackle is required to connect the slings at the top.

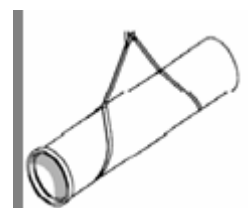

Fig. 21

18. LOAD

18.6.8. Mesh

Pass each hook of a four-legged chain through the mesh and return to form a choke hitch. Lifting points to be positioned evenly to prevent undue bending on the mesh bundle. Tighten bite as necessary. (see Fig. 22)

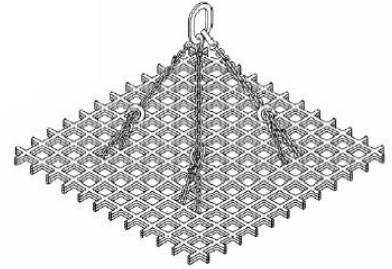

Fig. 22

18.6.9. Prefabricated Rebar Assemblies

These assemblies rely on tying wire to hold them together. Attachment points **MUST** be agreed (formally) with your Appointed Person and Temporary Works Coordinator.

18.6.10. ISO Containers and Portable Offices

⌚ Special lifting gear must be used to lift containers. This gear will be fitted with ISO Twist locks which are designed to fit the sockets in the corners of the container. Never use any type of hook, shackle or other device fitted directly into these sockets. (see Fig. 23)

⌚ Refer to the portable office manufacturers literature for maximum weight (office and contents), and for minimum sling leg length. Consider carefully for both offices and containers, secure jack legs. (see Fig. 24)

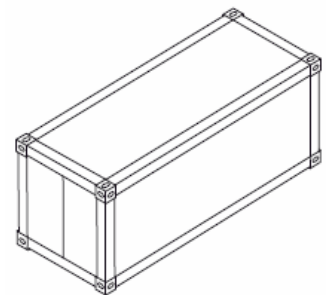

Fig. 23
CONTAINER

⌚ **To prevent them falling out check for:**

- Weight of contents
- Loose items that may slide during lifting
- Condition of floor of containers
- Access to attach and detach slings

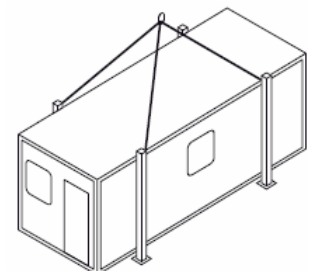

Fig. 24
PORTABLE OFFICE

18. LOAD

18.7. CENTRE OF GRAVITY AND SLING LOADING:

Centre of Gravity – is a point which, if the load could be suspended from it, the load would be in perfect balance.

The crane hook needs to be directly over the centre of gravity, for the load to be stable.

Fig.25 - This load is not stable. The hook is over the centre of gravity, but the centre of gravity is above the crane hook. This hook is top-heavy, and could overturn while being craned.

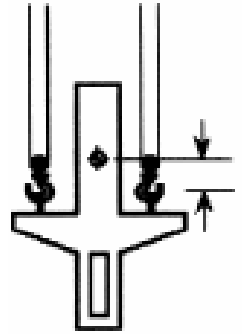

Fig. 25

Fig.26 & 27 - This load is not stable. The hook is not over the load's centre of gravity. Lifting a load with the centre of gravity offset will cause the load to shift until a balance is restored. The load will shift until the centre of gravity is under the hook. this will make landing the load very difficult, and could cause major problems in crainage.

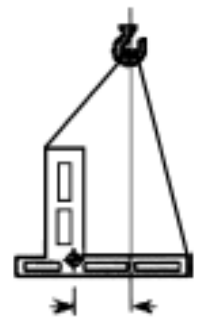

Fig. 26



Fig. 27

Fig. 28 – Start like this...

The hook is over the centre of gravity.

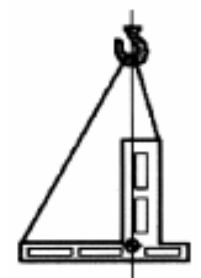

Fig. 28

19. TABLE/CHART

19.1. SHACKLE ANGULAR LOADING CAPACITY:

Side Loading Reduction and Strength Efficiency Values (For Screw Pin and Bolt-Type Shackles Only)

Angles From Horizontal	Reductions in Rated Capacity	Shackle Rated Capacity Multiplier
0° to 19°	50%	.50
20° to 34°	45%	.55
35° to 44°	40%	.60
45° to 59°	35%	.65
60° to 69°	25%	.75
70° to 79°	15%	.85
80° to 90°	0%	1.00

NOTE: Do not side load round pin shackles.

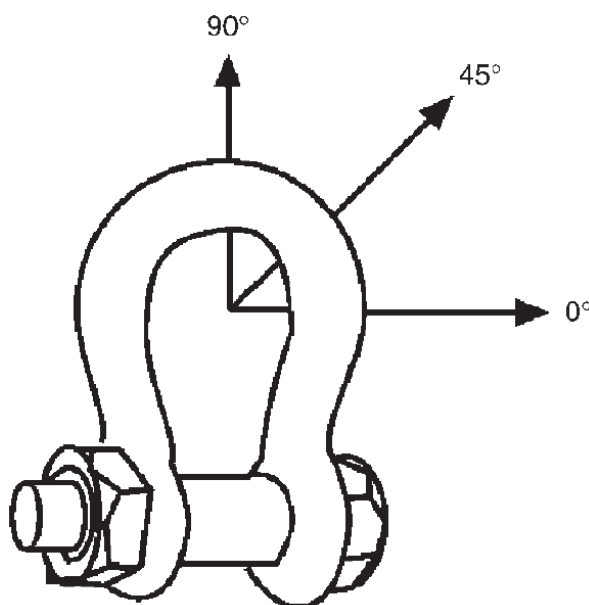

Fig. 1

19. TABLE/CHART

19.2. CONVERSION TABLE:

LENGTH

MULTIPLY		BY		TO OBTAIN
inches (in)	x	25.4	=	millimeters (mm)
	x	2.54	=	centimeters (cm)
feet (ft)	x	0.304 8	=	meters (m)
miles (mi)	x	1.609 344	=	kilometers (km)
millimeters	x	0.039 370 1	=	inches
	x	0.003 380 839	=	feet
meters	x	3.280 839 895	=	feet
	x	1 000.000	=	millimeters
kilometers	x	0.621 371 192	=	miles
	x	1 000.000	=	meters

MASS

MULTIPLY		BY		TO OBTAIN
ounces (oz) (avdp)	x	28.349 523 125	=	grams (g)
pounds (lbs) (avdp)	x	0.453 592 37	=	kilograms (kg)
tons (short)	x	0.907 184 74	=	metric tons (t)
grams	x	0.035 273 961	=	ounces
kilograms	x	2.204 622 622	=	pounds
metric ton	x	1.102 311 311	=	tons

VOLUME

MULTIPLY		BY		TO OBTAIN
cubic inches (in ³)	x	16.387 064	=	cubic centimeters (cm ³)
cubic feet (ft ³)	x	0.028 316 846	=	cubic meters (m ³)
cubic centimeters (cc, ml)	x	0.61 023 744	=	cubic inches
cubic meters	x	35.314 666 72	=	cubic feet
liters (L)	x	1.056 688 209	=	quarts (qt)
	x	33.814 022 70	=	fluid ounces (fl oz)
fluid ounces	x	29.573 529 562	=	cubic centimeters
quarts	x	0.946 352 946	=	liters
gallons (gal) (US)	x	3.785 411 784	=	liters

VELOCITY

MULTIPLY		BY		TO OBTAIN
miles per hour (mph)	x	1.609 344	=	kilometers per hour (kph)
kilometers per hour	x	0.621 371 192	=	miles per hour

19. TABLE/CHART

19.3. FORMULA-VOLUMES OF COMMON SHAPES:

PYRAMID $V = \frac{1}{4} L \times B \times H$

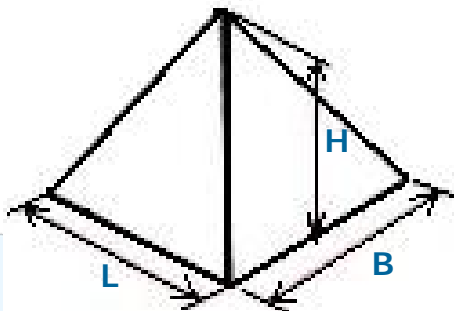

Fig. 3

SOLID CYLINDER $V = \pi \times r^2 \times L$

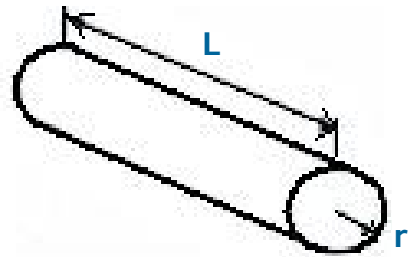

Fig. 4

RECTANGULAR SOLID $V = L \times B \times H$

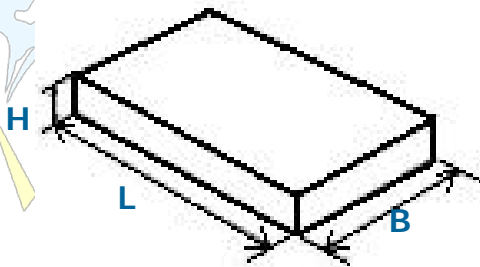

Fig. 5

THIN WALLED PIPE $V = \pi \times d \times L \times t$

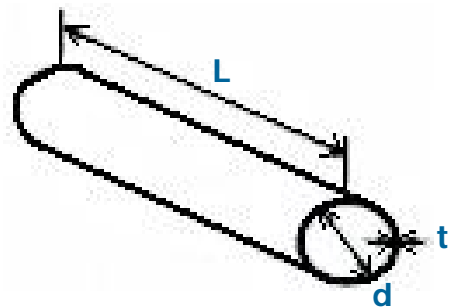

Fig. 6

SPHERE $V = \frac{4\pi \times r^3}{3}$

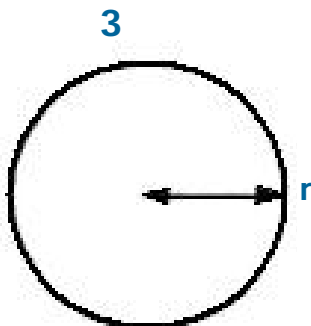
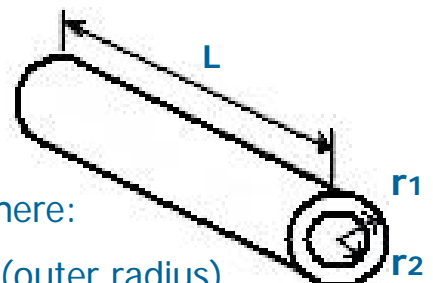

Fig. 7

THICK WALLED PIPE $V = \pi(r_1^2 - r_2^2) \times L$



Where:

r1 (outer radius)

r2 (inner radius)

Fig. 8

19. TABLE/CHART

19.4. APPROXIMATE DENSITY OF COMMON MATERIALS:

(All Weights in metric Tonnes)

Materials	Density kg/m ³	Density lbs/ft ³
Acetylene	1170	73
Aluminum	2725	170
Argon	1780	111
Brass	8350	520
Concrete	2250	140
Copper	8820	550
Iron	7690	480
Lead	11350	708
Oil	810	50
Paper	1130	70
Propane	2010	125
Rubber (Raw)	950	59
Sand (Dry)	1500	94
Sandstone	2500	156
Steel	7850	490
Water	1025	64
Wood (Average)	800	50

20. CALCULATION

20.1. EXAMPLES OF CALCULATING SLING LOADING:

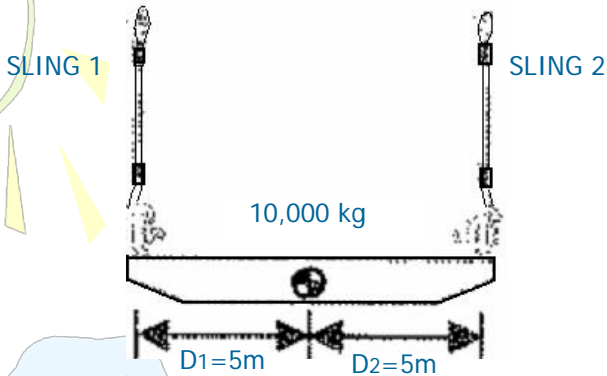

Fig. 1

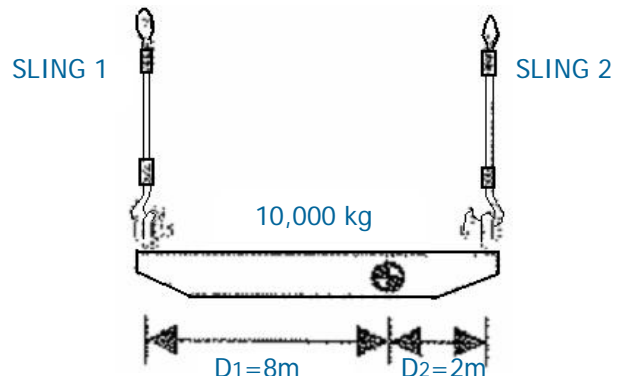

Fig. 2

$$\text{SLING 2 : } 10,000 \times 8 / (8+2) = 8,000 \text{ kg}$$

$$\text{SLING 1 : } 10,000 \times 2 / (8+2) = 2,000 \text{ KG}$$

Steps:

1. Determine the Horizontal sling angles. (45°)
2. Select corresponding Load Angle Factor. (1.414)
3. Multiply Load Weight by Load Angle Factor to get total load on sling legs. ($2000 \text{ kg} \times 1.414 = 2828 \text{ kg}$) **(Fig.3)**
4. Divide total load by the number of sling legs. ($2828 \text{ kg} \div 2 = 1414 \text{ kg}$ per sling leg)
5. Select slings from the single vertical leg column within the sling capacity table.

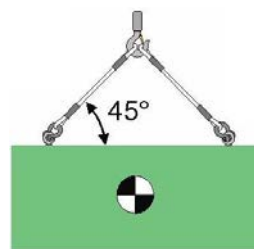

2000 kg
Fig. 3

Sling Angle (degrees)	Load Angle Factor
65°	1.104
60°	1.155
55°	1.221
50°	1.305
45°	1.414
40°	1.555
35°	1.742
30°	2.000

Note:

- When sling angles are between those listed in chart, use the next lower sling angle and corresponding load angle factor.
- When using 3 or 4 sling legs equal in length, divide the total load by 2.
- When the load is not distributed uniformly (equally) on sling legs, the tension on each leg must be calculated individually.

20. CALCULATION

20.2. EXAMPLES OF CALCULATING SLING LOADING:

Select slings to pick up the load shown below.

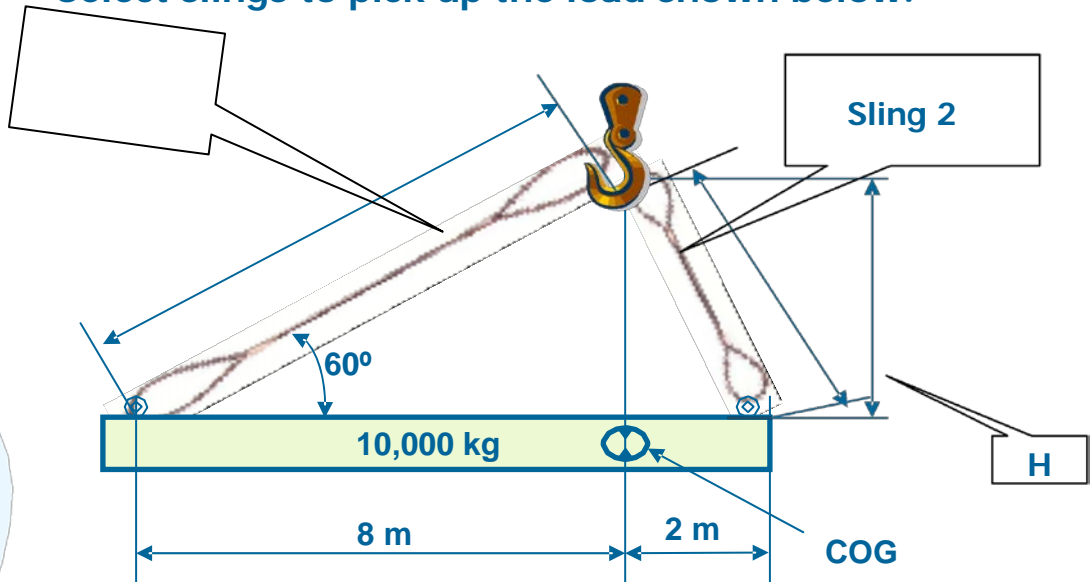

STEPS:

- Assume the position of hook directly over the center of gravity of load
- Consider an optimal angle of 60° to the horizontal of load
- Since the angle is 60°, the height of the hook is now fixed as is the sling length. Because the angle is 60°
- **Sling 1 length** at 60° = Base/cosine 60° = 8m/0.5 = 16m
- Knowing the L/H = 1.2 for 60° sling angle, the height of the hook is
 $L/H = 1.2$
 $H = 16/1.2$
 $H = 13.3 \text{ m}$
- Additionally, knowing that L/H = 1.2 for 60° sling angle, the load on sling 1
Force acting on sling 1 is 2000kg, Refer page no: 83, fig 2
- **Sling 1's SWL (minimum) calculation:**
Sling 1 = 1.2 x Force A or 1.2 x 2,000 kg = **2,400 kg**.
- Sling 2's length can now be calculated to an exact number
- **Length of sling 2** = $\sqrt{(13.3)^2 + (2)^2} = 13.44 \text{ m}$
- **Sling 2's SWL (minimum) calculation:**
- Force acting on sling 2 is 8000kg, Refer page no: 83, fig 2
 $L/H = 13.44/13.3 = 1.01$
Sling 2 = 1.01 x 8,000 kg = **8,084 kg**
- Using wire rope slings, 6 x 19 class rope
- With a ferrule secured wire rope slings, Use velosi Rigging chart no:12.1.1

20. CALCULATION

20.3. SLING ANGLES:

VERTICAL SLING ANGLE β	LOAD ANGLE FACTOR = L/H
0°	1.000
30°	1.155
45°	1.414
60°	2.000

LOAD ON EACH LEG OF SLING =
VERTICAL LOAD X LOAD ANGLE FACTOR

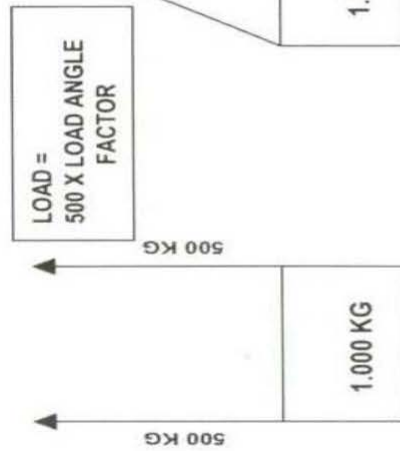
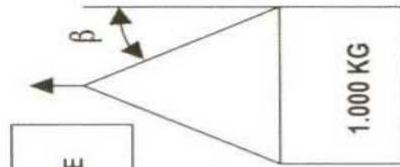
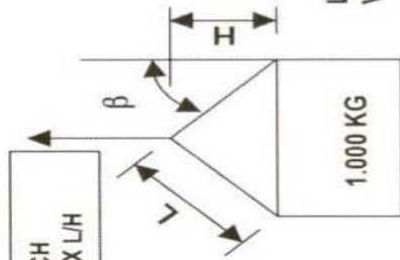

VERTICAL SLING ANGLE =
1/2 INCLUDED ANGLE

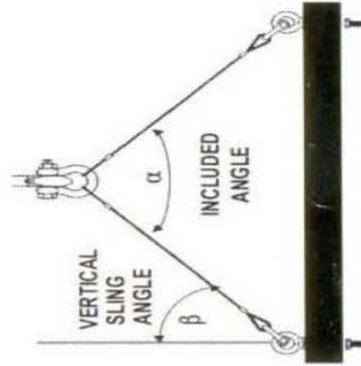

THE TOTAL OF ALL ANGLES
IN A BRIDLE = 180°

SLING LENGTH FOR DESIRED ANGLE

VERTICAL ANGLE	LENGTH FACTOR	L/H
60 DEGREES	1.15	2
50 DEGREES	1.31	1.55
45 DEGREES	1.41	1.4
40 DEGREES	1.55	1.3
35 DEGREES	1.74	1.21
30 DEGREES	2	1.16

LENGTH S = D X (LENGTH FACTOR)

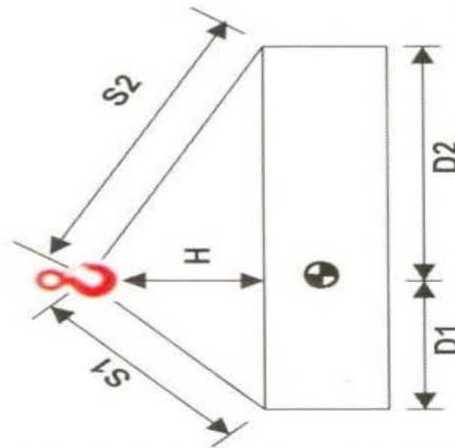

UNEQUAL LEGS



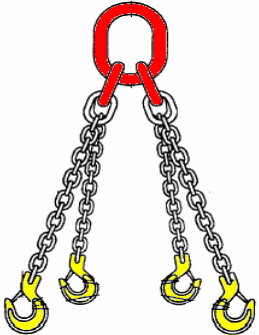

LOAD ON SLING CALCULATED

TENSION 1 = $\text{LOAD} \times D_2 \times S_1 / H(D_1 + D_2)$
TENSION 2 = $\text{LOAD} \times D_1 \times S_2 / H(D_1 + D_2)$



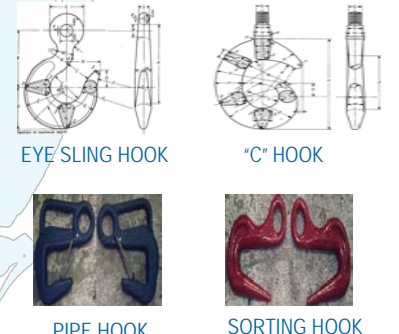
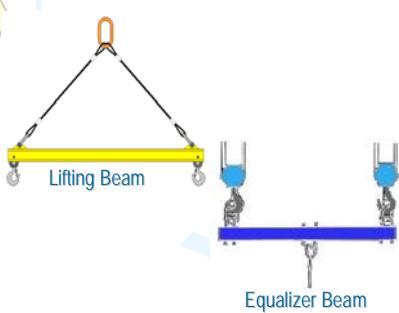

21. GLOSSARY

No.	PICTURE	DESIGNATION	DESCRIPTION	STANDARD/ REFERENCE
1		Steel Wire Rope Slings and their components	Assembly of one or more steel wire rope legs or an endless sling for attaching loads to the hook of a crane on other lifting machine	BS EN 13414- 1 other ASME B30.9
2		Chain Slings and their components	Assembly of one or more chains for attaching loads to the hooks of a crane or other lifting machine	BS EN 818-4,5,6 other ASME B30.9, ISO 7593
3	 <p>FLAT WEBBING SLING</p> <p>ROUND WEBBING SLING</p>	Textile Slings and their components	Assembly of one or more sewn webbing components for attaching loads to the hook of a crane or other lifting machine.	BS EN 1492- 1 and 2 other ASME B30.9
4	 <p>DEE SHACKLE</p> <p>BOW SHACKLE</p>	Shackles (Dee & Bow type shackle)	Suitable for use with the eyes and bodies of hooks, eyebolts, egg links, wire rope thimbles, and for the head fittings of blocks, etc.	BS 3551 other US-FED. SPEC-RR-C-271D

21. GLOSSARY

No.	PICTURE	DESIGNATION	DESCRIPTION	STANDARD/ REFERENCE
5	 <p>VERTICAL LIFTING LOCKING</p> <p>HORIZONTAL LIFTING NON-LOCKING</p> <p>LOCKING SCREW</p>	Clamps (Vertical, Horizontal lifting & Locking Screw types)	<p>Plate clamps are used to lift and transfer metal plates during rigging applications.</p> <p>Horizontal Clamps- lift of non-sagging plates or bundles.</p> <p>Vertical Clamps- are used for turning, lifting, or moving of sheets, plates or fabrications.</p>	BS 13155 other LOLER, ASME B30.20
6	 <p>EYE SLING HOOK</p> <p>"C" HOOK</p> <p>PIPE HOOK</p> <p>SORTING HOOK</p>	Hook (Eye Sling, "C" Hook, Sorting & Pipe Hook types)	Is a device for lifting loads by means of a device such as a hoist or crane.	BS EN 1677-1, 2, 3, 5 other ASME B30.10, ISO 7597, ISO 8539
7	 <p>Lifting Beam</p> <p>Equalizer Beam</p>	Lifting Beams (Spreader & Equalizer Beam types) and their components	A crosspiece for spacing the chains or cables hanging from the hook of a crane.	LOLER / QP REG. REV.03
8		Hand-Operated Chain Block and their components	A device for lifting and lowering a load suspended from one chain (the load chain) by means of human effort applied to another chain (the hand chain) and for holding the load.	BS EN 13157: 2004

21. GLOSSARY

No.	PICTURE	DESIGNATION	DESCRIPTION	STANDARD/ REFERENCE
9		Chain Lever Hoist and their components.	A portable tool reeved with a load chain, and operated by a lever so as to give a mechanical advantage.	BS EN 13157 other ASME B30.21
10		Wire rope grip/pull lifting machine (Tirfor)	A diverters, pulley blocks- anchorage and suspension points – imposed loads.	BS EN 13157
11	 <p>Hook & Eye Eye & Eye Hook & Hook Jaw & Eye Jaw & Jaw</p>	Turnbuckles with different types	Rigging screw- a tubular body internally threaded at each end, with one right-hand & one left-hand thread. Turnbuckles- an open body consisting of reins, with bosses at each end & internally threaded at each end, with one right-hand & one left-hand thread.	BS 4429: 1987
12	 <p>FIXED CLAMP</p> <p>ADJUSTABLE CLAMP</p>	Beam Clamps with two types Fixed & Adjustable.		BS 13155 other LOLER, ASME B30.20

Lifting Plan

Lift Description: _____

Lift Supervisor: _____

Lift Date: _____

Lift Criteria	Notes/Comments
1. What item(s) will be lifted?	
2. Are there any special precautions (such as mats for mobile cranes)?	
3. What is the weight of each item and total weight of the load? (For mobile cranes, see the manufacturer's instructions about components and attachments that must be considered as part of the load.)	
4. Where is the center of gravity located? Note: The center of gravity of an object is that point at which the object will balance. A stable load is one in which the center of gravity of the load is directly below the main hook and below the lowest point of attachment of the slings.	
5. List each piece of equipment, accessory, and rigging component, by type and rated capacity, that will be used during the lift.	
a. Crane	
b. Hoist	
c. Fork Truck	
d. Slings (identify the configuration used: choker, basket, or vertical, and angle (see Figure 1 below))	
e. Shackles	
f. Eye Bolts/Swivel Eyes	
g. Turnbuckles	
h. Spreader Bars	
i. Hook (Type and WLL)	
j. Other (Special Lifting Fixture, Below the Hook Lifting Devices, Multi Leg Bridle, etc)	
6. Are there designated checkpoints or hold points?	
7. If yes, list them and their estimated instrument readings, as relevant, so that job progress can be checked against the plan.	
8. How will you rig the load?	
9. Will tag lines be needed to control the load?	
10. What personnel will you need to assist with the lift?	
a. Crane operator	
b. Riggers	

c. Spotters	
d. Tag Line Handlers	
e. Fork truck driver	
f. Other	
11. Safety equipment (hard hats, safety shoes, gloves)	
12. Mobile Crane location	
a. Will crane be set up on concrete? If yes, can concrete support the weight of the crane and the load?	
b. Will crane be set up on asphalt? If yes, will cribbing be needed (for asphalt temp > 90° F)?	
c. Will crane be set up on gravel or rough ground? If yes, cribbing will be required.	
13. Are any of the structures listed below located in the area of the crane set up? If yes, indicate their location on the Load Path Sketch.	
a. Manholes	
b. Underground voids	
c. Pipe chases	
d. Overhead obstructions or power lines	
14. Additional information	

The chart in the middle offers a handy guide for assessing the effective angle of the sling to the relative weight. It is always better to limit the angle of the sling. Further, such changes in sling angle must be accounted for in lifts that are close to the sling weight limit and/or for critical lifts (greater than 90% of the crane limit).

Rigging Sketch



Identify the following on your sketch:

- a. Lift point identification
- b. Method(s) of attachment
- c. Load angle factors (e.g., vertical and horizontal vectors of sling loads)
- d. Sling angles
- e. Accessories used
- f. Other factors affecting the equipment capacity
- g. Rated capacity of equipment in the configuration(s) in which it will be used. (For mobile cranes, many factors affect rated capacity, including boom length, boom angle, and work area.)

Load Path Sketch

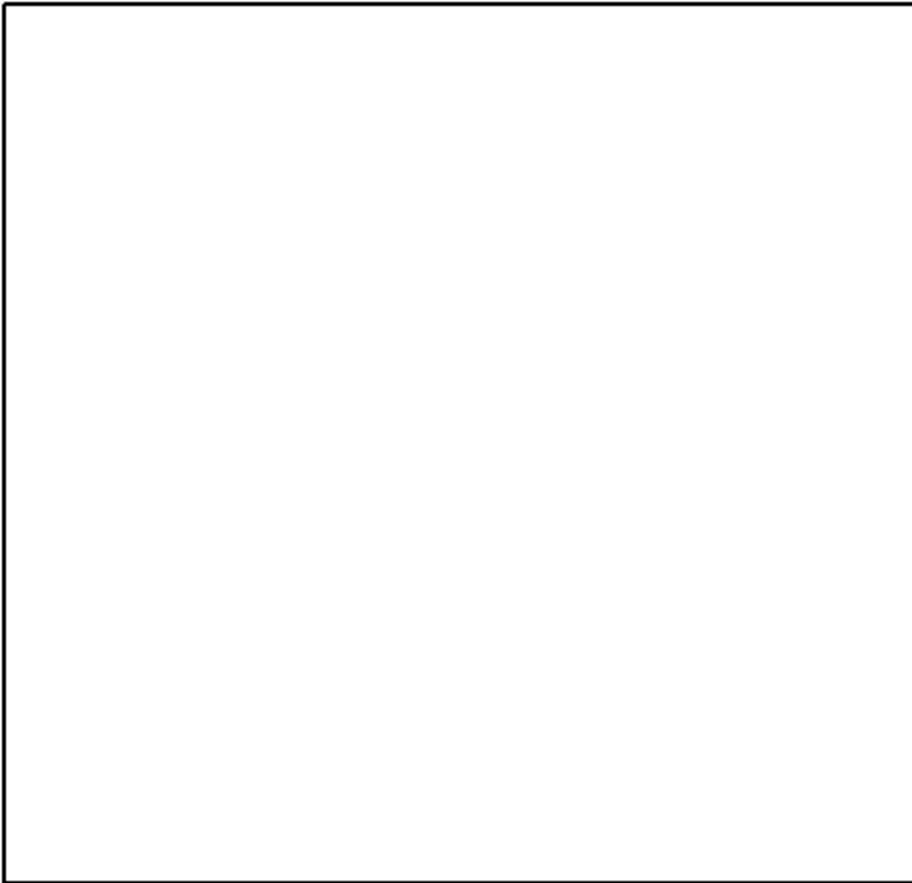

A load-path sketch shows the load path and height at key points in the job. For lifts with mobile cranes, include the crane position(s) relative to the load and relative to surrounding obstructions. Where appropriate, include floor or soil-loading diagrams. Indicate lifting and travel speed limitations if applicable.

Ashraf Al Mghrbl

E H S C o n s u l t a n t

petro.hse@gmail.com

whatsapp : 002 0100 10 378 39

Lifting Equipment and the Law

The Detail Of The Legislation

THE ACTS & REGULATIONS IN DETAIL

- The Lifting Operations and Lifting Equipment Regulations 1998
- The Management of Health and Safety at Work Reg's 1999
- The Provision and Use of Work Equipment Regulations 1998
- The Supply of Machinery (Safety) (Amendment) Regulations 1994
- The Health and Safety at Work Act 1974

Where Does the Law Come From?

There are currently five pieces of legislation which affect people whose work brings them into contact with lifting equipment. These Acts and Regulations are -

- The Lifting Operations and Lifting Equipment Regulations 1998
- The Management of Health and Safety at Work Regulations 1999
- The Provision and Use of Work Equipment Regulations 1998
- The Supply of Machinery (Safety) (Amendments) Regulations 1994 and the EC Machinery Directive 98/37/EC.
- The Health and Safety at Work Act 1974

Who has responsibilities?

More or less everyone who has any contact or dealing with lifting equipment.

Specific responsibilities are given to -

- The employer of a person who uses lifting equipment at work. All responsibilities ascribed to an employer apply to any person who has control over or supervises the use of lifting equipment.
- The self-employed who uses lifting equipment.
- The equipment user.
- The equipment examiner.
- The designer, supplier and manufacturer of lifting equipment.

What particular responsibilities do these people have?

The employer must -

Under LOLER Reg.4	Ensure that lifting equipment used in his workplace is of adequate strength and stability for each load.
Under LOLER Reg.5	Make special provisions for lifting equipment that carries people.
Under LOLER Reg.6	Ensure that lifting equipment is installed in such a way as to minimise the risk of a person being struck by a load, and is otherwise safe.
Under LOLER Reg.7	Ensure that lifting equipment is marked with its Safe Working Load.
Under LOLER Reg.8	Ensure that every lifting operation involving lifting equipment is (a) properly planned by a competent person; (b) appropriately supervised; and (c) carried out in a safe manner.
Under LOLER Reg.9	Have in his possession before the first use of any equipment - (a) a Report of Thorough Examination of Lifting Equipment; or (b) an EC Declaration of Conformity if the equipment has not been used before.
Under LOLER Reg.9	(a) Examine "below the hook" items every 6 months. (b) Examine "above the hook" items every 12 months. (c) Examine more frequently if circumstances require. (d) Routine inspect between examinations, where safety requires.
Under LOLER Reg.10	Ensure that equipment is not used until a notified defect is rectified.
Under LOLER Reg.11	Keep the following documents - (a) EC Declaration of Conformity as long as he keeps the equipment (b) Report of Thorough Examination for "below the hook" items when examined before first use, for 2 years. (c) Report of Thorough Examination for "above the hook" items when examined before first use, as long as he keeps the equipment. (d) Report of Thorough Examination for all periodic examinations, for 2 years.

What particular responsibilities do these people have? cont..

Under MHSWR Reg.13	Ensure that his employees are provided with adequate training on their being exposed to new or increased risks because of the introduction of new work equipment or a change of work equipment already in use.
Under PUWER Reg.4	Ensure that work equipment is maintained in an efficient state, in efficient working order and in good repair.
Under PUWER Reg.9	Ensure that all employees who use, or supervise or manage the use of work equipment, have received adequate training in safety, methods, risks and precautions.
Under HSWA s.2	<ul style="list-style-type: none"> (a) Provide a safe place of work. (b) Provide safe handling systems. (c) Maintain equipment at work. (d) Provide adequate training.

The self-employed have the same responsibilities as the employer above.

The equipment user must -

Under HSWA s.7	Take care of himself and others whom his acts or omissions at work might affect.
----------------	--

The examiner must -

Under LOLER Reg.10	<ul style="list-style-type: none"> (a) Immediately notify the employer of any defect he finds. (b) Give to the employer a written "Report of Thorough Examination of Lifting Equipment". (c) Notify the Health & Safety Executive of any imminent risk of serious personal injury.
--------------------	---

The designer, supplier and manufacturer must -

Under HSWA s.6	<ul style="list-style-type: none"> (a) Ensure that the equipment he designs and makes is safe. (b) Ensure it is installed safely. (c) Carry out necessary tests and examinations to ensure safety. (d) Provide adequate "Safe Use" information.
Under SMR Reg 12	<ul style="list-style-type: none"> (a) Issue an EC Declaration of Conformity (b) Fix a CE mark to the equipment (c) Ensure that his machinery complies with the essential health and safety requirements to offset the particular hazards due to a lifting operation.



Petro HSE

@petro.hse

CALL NOW

SEND...



Like



Follow



Send Email



Save



The Details of the Legislation

The Lifting Operations and Lifting Equipment Regulations 1998

Referred to below as "LOLER".

Came into force 5th December 1998.

A Regulation under the Health and Safety at Work etc. Act 1974.

Wording lifted direct from LOLER in Italics.

Definitions (LOLER Regulation 2)

- *"accessory for lifting" means work equipment for attaching loads to machinery for lifting.* It can be assumed that an "accessory for lifting" is what used to be described as "lifting tackle" and includes slings, shackles, eyebolts, lifting beams and all "below the hook" items of lifting equipment.
- *"examination scheme" means a suitable scheme drawn up by a competent person for such thorough examinations of lifting equipment at such intervals as may be appropriate for the purpose described in LOLER.*

The definition of a "competent person" is conspicuous by its absence.

- *"the Executive" means the Health and Safety Executive.*
- *"lifting equipment" means work equipment for lifting or lowering loads and includes its attachments used for anchoring, fixing or supporting it.* This definition of lifting equipment goes beyond the pre-LOLER definition in that supporting stools, guys and other such supports are included.
- *"lifting operation" means an operation concerned with the lifting or lowering of a load.*
- *"load" includes a person.*
- *"thorough examination"*
 - (a) *means a thorough examination by a competent person;*
 - (b) *where it is appropriate to carry out testing for the purpose described in [LOLER], includes such testing by a competent person as is appropriate for the purpose.*
- *"work equipment" means any machinery, appliance, apparatus, tool or installation for use at work.*

Application (LOLER Regulation 3)

(1) LOLER shall apply -

- (a) *in Great Britain...*

(2) LOLER shall apply to *an employer in respect of lifting equipment.....provided for use or used by an employee of his at work.*

(3) LOLER shall also apply -

- (a) *to a self-employed person in respect of lifting equipment he uses at work.*
- (b) *to a person who has control to any extent of -*
 - (i) *lifting equipment;*
 - (ii) *a person at work who uses or supervises or manages the use of lifting equipment; or*
 - (iii) *the way in which lifting equipment is used.*

LOLER specifically excludes some, but not all, shipping operations.

The Lifting Operations and Lifting Equipment Regulations 1998 cont..

Strength and stability (LOLER Regulation 4) -

Every employer shall ensure that

- (a) lifting equipment is of adequate strength and stability for each load, having regard in particular to the stress induced at its mounting or fixing point;
- (b) every part of a load and anything attached to it and used in lifting it is of adequate strength.

Lifting equipment for lifting persons (LOLER Regulation 5)

(1) Every employer shall ensure that lifting equipment for lifting persons -

- (a) is such as to prevent a person using it being crushed, trapped or struck or falling from the carrier;
- (b) is such as to prevent as far as is reasonably practicable a person using it, while carrying out activities from the carrier, being crushed, trapped or struck or falling from the carrier;
- (c) has suitable devices to prevent the risk of a carrier falling;
- (d) is such that a person trapped in any carrier is not thereby exposed to danger and can be freed.

(2) Every employer shall ensure that if the risk described in paragraph (1) (c) [above] cannot be prevented for reasons inherent in the site and height differences -

- (a) the carrier has an enhanced safety coefficient suspension rope or chain; and
- (b) the rope or chain is inspected by a competent person every working day.

Positioning and installing (LOLER Regulation 6)

(1) Every employer shall ensure that lifting equipment is positioned or installed in such a way as to reduce to as low as is reasonably practicable the risk -

- (a) of the lifting equipment or load striking a person; or
 - (b) from a load -
 - (i) drifting;
 - (ii) falling freely; or
 - (iii) being released unintentionally; and is otherwise safe.
- "and is otherwise safe" is a significant catch-all. Lifting installations must be safe!

(2) Every employer shall ensure that there are suitable devices to prevent a person from falling down a shaft or hoistway.

Marking of lifting equipment (LOLER Regulation 7)

Every employer shall ensure that

- (a) machinery and accessories for lifting loads are clearly marked to indicate their safe working loads;
- (b) where the safe working load of machinery for lifting loads depends on its configuration -
 - (i) the machinery is clearly marked to indicate its safe working load for each configuration; or
 - (ii) information which clearly indicates its safe working load for each configuration is kept with the machinery;
- (c) accessories for lifting are also marked in such a way that it is possible to identify the characteristics for their safe use;
- (d) lifting equipment which is designed for lifting persons is appropriately and clearly marked to this effect; and
- (e) lifting equipment which is not designed for lifting persons but which might be so used in error is appropriately and clearly marked to the effect that it is not designed for lifting persons.

The Lifting Operations and Lifting Equipment Regulations 1998 cont...

Organisation of lifting operations (LOLER Regulation 8)

- (1) Every employer shall ensure that every lifting operation involving lifting equipment is
- (d) properly planned by a competent person;
 - (e) appropriately supervised; and
 - (f) carried out in a safe manner.

This is a new concept to lifting equipment legislation. It is the "operation" not just the equipment that must be safe.

Thorough examination and inspection (LOLER Regulation 9)

- (1) Every employer shall ensure that before lifting equipment is put into service for the first time by him it is thoroughly examined for any defect unless either -
- (a) the lifting equipment has not been used before; and
 - (b) the employer has an EC declaration of conformity made not more than 12 months before the equipment is put into service.
- (2) Every employer shall ensure that, where the safety of lifting equipment depends on the installation conditions, it is thoroughly examined
- (a) after installation and before being put into service for the first time; and
 - (b) after assembly and before being put into service at a new site or a new location, to ensure that it has been installed correctly and is safe to operate.
- (3) Every employer shall ensure that lifting equipment which is exposed to conditions causing deterioration which is liable to result in dangerous situations is
- (a) thoroughly examined -
 - (i) in the case of lifting equipment for lifting persons or an accessory for lifting, at least every 6 months;
 - (ii) in the case of other lifting equipment, at least every 12 months; or
 - (iii) in either case, in accordance with an examination scheme; and
 - (iv) each time that exceptional circumstances which are liable to jeopardise the safety of the lifting equipment have occurred; and
 - (b) if appropriate for the purpose, is inspected by a competent person at suitable intervals between thorough examinations, to ensure that health and safety conditions are maintained and that any deterioration can be detected and remedied in good time.

Reports and defects (LOLER Regulation 10)

- (1) A person making a thorough examination for an employer under regulation 9 [of LOLER] shall-
- (a) notify the employer forthwith of any defect in the lifting equipment which in his opinion is or could become a danger to persons;
 - (b) as soon as is practicable make a report of the thorough examination in writing signed by him or on his behalf.....and containing the information specified in Schedule 1 to -
 - (i) the employer; and
 - (ii) any person from whom the lifting equipment has been hired or leased;
 - (c) where there is in his opinion a defect in the lifting equipment involving an existing or imminent risk of serious personal injury send a copy of the report as soon as is practicable to the relevant enforcing authority.
- (2) A person making an inspection for an employer under regulation 9 [of LOLER] shall -
- (a) notify the employer forthwith of any defect in the lifting equipment which in his opinion is or

The Lifting Operations and Lifting Equipment Regulations 1998 cont...

- could become a danger to persons;
- (b) as soon as is practicable make a record of the inspection in writing.

- (3) Every employer who has been notified [of a defect] shall ensure that lifting equipment is not used -
- (a) before the defect is rectified; or
 - (b) after a time specified [in the defect report] and before the defect is rectified.

Keeping information (LOLER Regulation 11)

- (1) an EC declaration of conformity [shall be kept by an employer] so long as he operates the lifting equipment.
- (2) The employer shall ensure that the information contained in -
- (a) every report of thorough examination is kept available for inspection -
 - (i) ...for a "prior to first use thorough examination of equipment" (i.e. under Regulation 9 (1)) lifting equipment other than an accessory for lifting (i.e. for "above the hook" equipment) until he ceases to use the lifting equipment;
 - (ii) ...for a "prior to first use thorough examination of equipment" (i.e. under Regulation 9 (1)) an accessory for lifting, (i.e. for "below the hook" equipment) for two years after the report is made.
 - (iii) ...for a "prior to first use thorough examination of installation" (i.e. under Regulation 9 (2)) until he ceases to use the lifting equipment it was installed or assembled.
 - (iv) ...for a "periodic examination of equipment" (i.e. under Regulation 9 (3)) until the next report is made.....or the expiration of two years whichever is later.
 - (b) every [inspection record] is kept available until the next such record is made.

Repeal of provisions of the Factories Act 1961 (LOLER Regulation 15)

Sections 22,23 and 25 to 27 of the Factories Act 1961 (d) are repealed.

Information to be contained in a report of a thorough examination (Schedule 1)

- 1 The name and address of the employer for whom the thorough examination was made.
- 2 The address of the premises at which the thorough examination was made.
- 3 Particulars sufficient to identify the lifting equipment including where known its date of manufacture.
- 4 The date of the last thorough examination.
- 5 The safe working load of the lifting equipment or (where its safe working load depends on the configuration of the lifting equipment) its safe working load for the last configuration in which it was thoroughly examined.
- 6 In relation to the first thorough examination of lifting equipment after installation or after assembly at a new site or in a new location -
 - (a) that it is such a thorough examination;
 - (b) (if such be the case) that it has been installed correctly and would be safe to operate.
- 7 In relation to a thorough examination of lifting equipment other than a thorough examination to which paragraph 6 relates -
 - (a) whether it is a thorough examination -
 - (i) within an interval of 6 months under regulation 9(3)(a)(i);
 - (ii) within an interval of 12 months under regulation 9(3)(a)(ii);
 - (iii) in accordance with an examination scheme under regulation 9(3)(a)(iii); or
 - (iv) after the occurrence of exceptional circumstances under regulation 9(3)(a)(iv);
 - (v) (if such be the case) that the lifting equipment would be safe to operate.
- 8 In relation to every thorough examination of lifting equipment -
 - (a) identification of any part found to have a defect which is or could become a danger to persons, and a description of the defect;
 - (b) particulars or any repair, renewal or alteration required to remedy a defect found to be a danger to persons;

The Lifting Operations and Lifting Equipment Regulations 1998 cont...

- (c) *in the case of a defect which is not yet but could become a danger to persons -*
 - (i) *the time by which it could become such a danger;*
 - (ii) *particulars of any repair, renewal or alteration required to remedy it;*
 - (d) *the latest date by which the next thorough examination must be carried out;*
 - (e) *where the thorough examination included testing, particulars of any test;*
 - (f) *the date of thorough examination.*
9. *The name, address and qualifications of the person making the report; that he is self-employed or, if employed, the name and address of his employer.*
- 10 *The name and address of a person signing or authenticating the report on behalf of its author.*
11. *The date of the report.*

The Management of Health and Safety at Work Reg's 1999

Referred to below as "MHSWR".

Came into force 29th December 1999.

A Regulation under the Health and Safety at Work etc. Act 1974.

Wording lifted direct from MHSWR in Italics

Capabilities and training (MHSWR Regulation 13)

- (2) *Every employer shall ensure that his employees are provided with adequate health and safety training -*
- (b) *on their being exposed to new or increased risks because of -*
 - (iii) *the introduction of new work equipment or a change respecting work equipment already in use within the employer's undertaking.*

The Provision and Use of Work Equipment Regulations 1998

Referred to below as "PUWER".

Came into force 5th December 1998.

A Regulation under the Health and Safety at Work etc. Act 1974.

Wording lifted direct from PUWER in Italics

Interpretation (PUWER Regulation 2)

- (1) *... "work equipment" means machinery, appliance, apparatus, tool or installation for use at work...*

Application (PUWER Regulation 3)

- (1) PUWER shall apply in Great Britain.

Suitability of work equipment (PUWER Regulation 4)

- (1) *Every employer shall ensure that work equipment is maintained in an efficient state, in efficient working order and in good repair.*

The Lifting Operations and Lifting Equipment Regulations 1998

Training (PUWER Regulation 9)

- (1) *Every employer shall ensure that all persons who use work equipment have received adequate training for purposes of health and safety, including training in the methods which may be adopted when using the work equipment, any risks which such use may entail and precautions to be taken.*
- (2) *Every employer shall ensure that any of his employees who supervises or manages the use of work equipment has received adequate training for purposes of health and safety, including training in the methods which may be adopted when using the work equipment, any risks which such use may entail and precautions to be taken.*

The Supply of Machinery (Safety) (Amendment) Regulations 1994

Referred to below as "SMR".

Came into force 1st January 1993.

Requirements for Supply of Relevant Machinery (Regulation 12)

The manufacturer (or original importer into the EC) of a lifting machine (the definition of machine includes all useable equipment, e.g. shackles, chain slings) must

- (a) Satisfy the relevant health and safety requirements detailed in the SMR (see below).
- (b) Carry out an appropriate test and assessment procedures.
- (c) Issue an EC Declaration of Conformity.
- (d) Fix a CE mark.
- (e) Ensure the machinery is in fact safe.

Essential Health and Safety Requirements to Offset the Particular Hazards Due to a Lifting Operation (Schedule 4)

The SMR places requirements on the designer and manufacturer of machinery. These requirements cover -

- (a) Stability.
- (b) Guide rails and rail tracks.
- (c) Mechanical strength.
- (d) Pulleys, drums, chains or ropes.
- (e) Separate lifting accessories.
- (f) Control of movements.
- (g) Handling of loads.
- (h) Control devices.
- (i) Loading control.
- (j) Risks to exposed persons.
- (k) Fitness for purpose.
- (l) Marking.
- (m) Instruction handbook.

The requirements are detailed, but it is the responsibility of the Rossendale Group to ensure that they are complied with when it manufactures and supplies or installs lifting equipment.

When the Rossendale Group supplies equipment manufactured by others, it is the responsibility of the manufacturer (or supplier) to ensure compliance with the essential health and safety requirements.

Under SMR a 'machine' is much more broadly defined than our traditional understanding. If it is a piece of lifting equipment capable of being used on its own, it is a 'machine' under SMR. This would include a shackle or a sling.

The Health and Safety at Work Act 1974

Referred to below as "HSWA".

Wording lifted direct from HSWA in Italics

General Duties of Employers to their Employees (HSWA Section 2)

(1) *It shall be the duty of every employer to ensure, so far as is reasonably practicable, the health, safety and welfare at work of all his employees.*

(2) *...the matters to which that duty extends in particular -*

- (a) *the provision and maintenance of plant and systems of work that are, so far as is reasonably practicable, safe and without risks to health;*
- (b) *arrangements for ensuring, so far as is reasonably practicable, safety and absence of risks to health in connection with the use, handling, storage and transport of articles and substances;*
- (c) *the provision of such information, instruction, training and supervision as is necessary to ensure, so far as is reasonably practicable, the health and safety at work of his employees.*
- (d) *so far as is reasonably practicable as regards any place of work under the employer's control, the maintenance of it in a condition that is safe and without risks to health...*
- (e) *The provision and maintenance of a work environment for his employees that is, so far as is reasonably practicable, safe...*

General Duties of Manufacturers (HSWA Section 6)

(1) *It shall be the duty of any person who designs, manufactures, imports or supplies [lifting equipment] -*

- (a) *to ensure, so far as is reasonably practicable, that the [equipment] is designed and constructed as*

to be safe and to be without risks to health when properly used;

(2) *"When properly used" is a significant caveat.*

- (b) *to carry out.....such testing and examination as may be necessary [to ensure that it is safe];*

- (c) *to make available adequate information about the use for which [the equipment] is designed.....and about any conditions necessary to ensure that, when put to that use, it will be safe and without risks to health.*

(3) *It shall be the duty of any person who erects or installs any article for use at work, so far as is reasonably practicable, that nothing about the way in which it is erected or installed makes it unsafe.....when properly used.*

General Duties of Employees at Work (HSWA Section 7)

It shall be the duty of every employee, while at work -

- (a) *to take reasonable care for the health and safety of himself and of other persons who may be affected by his acts or omissions at work.*

American Institute of Steel Construction

AISC Specifications for the design, fabrication, and erection of structural steel for buildings.

American Iron and Steel Institute

AISI Standards for Type-302 or Type-304 stainless steel.

**American National Standards Institute
and
American Society of Mechanical
Engineers**

ANSI A10.28, Work Platforms Suspended From Cranes or Derricks.

ANSI A10.18, Floor and Wall Openings, Railings and Toe Boards.

ASME B30.2, Overhead and Gantry Cranes (Top-Running Bridge, Single or Multiple Girder, Top-Running Trolley Hoist).

ASME B30.5, Mobile and Locomotive Cranes.

ASME B30.6, Derricks.

ASME B30.7, Base-Mounted Drum Hoists.

ASME B30.9, Slings.

ASME B30.10, Hooks.

ASME B30.11, Monorail Systems and Underhung Cranes.

ASME B30.12, Handling Loads Suspended from Rotorcraft.

ASME B30.14, Side Boom Tractors.

ASME B30.16, Overhead Hoists (Underhung).

ASME B30.17, Overhead and Gantry Cranes (Top Running Bridge, Single Girder, Underhung Hoist).

ASME B30.20, Below-The-Hook Lifting Devices.

ASME B30.21, Manually Lever Operated Hoists.

ASME B30.22, Articulating Boom Cranes.

ASME B30.23, Personnel Lifting Systems.

ASME B56.1, Safety Standard for Powered Industrial Trucks – Low Lift and High Lift Trucks.

ASME B56.5, Guided Industrial Vehicles.

ASME B56.6, Rough Terrain Fork Lift Trucks.

ASME B56.7, Industrial Crane Trucks.
Special Notice 6-88.

ASME B56.11.4, Forks and Fork Carriers for Powered Industrial Fork Lift Trucks, Hook Type.

ASME PALD, Portable Automotive Lifting Devices.

ANSI/ASTM Specification A391, Specification for Alloy Steel Chain.

ANSI/ASTM Specification E-165, Standard Practice for Liquid Penetrant Inspection Method.

ANSI/ASTM Specification E-709, Standard Practice for Magnetic Particle Examination.

ANSI/AWS D14.1, Specification for Welding of Industrial and Mill Cranes and Other Material Handling Equipment.

ASME HST-1M, Performance Standard for Electric Chain Hoists.

ASME HST-2M, Performance Standard for Hand Chain Manually Operated Chain Hoists.

ANSI/ASME HST-3M, Performance Standard for Manually Lever Operated Chain Hoists.

ANSI/ASME HST-4M, Performance Standard for Electric Wire Rope Hoists.

ANSI/ASME HST-5M, Performance Standard for Air Chain Hoists.

ANSI/ASME HST-6M, Performance Standard for Air Wire Rope Hoists.

ANSI MH 27.1, Specifications for Underhung Cranes and Monorail Systems.

ANSI N14.6, Standard for Special Lifting Devices for shipping Containers Weighing 10,000 Pounds (4500 kg) or More for Nuclear Materials.

ASME NQA-1, Quality Assurance Program Requirements for Nuclear Facilities.

ASME Cranes for Nuclear Facilities:

ASME NUM-1, Rules for Construction of Cranes, Monorails, and Hoists (With Bridge or Trolley or Hoist of the Underhung Type).

ASME NOG-1, Rule for Construction of Overhead and Gantry Cranes (Toprunning Bridge, Multiple Girder).

American Society for Nondestructive Testing

Recommended Practice No. ASNT-TC-1A.

American Welding Society

ANSI/AWS D1.1 Structural Welding Code – Steel.

Crane Manufacturers' Association of America

CMAA No. 70, Specification for Electric Overhead Traveling Cranes.

CMAA No. 74, Specification for Top Running and Under Running, Single Girder, Electric Overhead Traveling Cranes.

Department of Energy

DOE 440.1A, Worker Protection Management for Federal and Contractor Employees.

DOE 440.1-6, Suspect Counterfeit Items Guide.

Department of Labor

29 CFR 1910, Occupational Safety and Health Standards for General Industry.

29 CFR 1926, Occupational Safety and Health Regulations for Construction.

Department of Transportation

49 CFR 391.41, physical Qualification for Drivers.

National Fire Protection Association

ANSI/NFPA 505, Powered Industrial Trucks, Type Designation and Areas of Use.

NFPA 70, National Electrical Code.

Power Crane and Shovel Association

PCSA-4, Mobile Power Crane and Excavator Standards and Hydraulic Crane Standards.

Society of Automotive Engineers

SAE J376-85, Load-Indicating Devices in Lifting Crane Service.

Code.SAE J765, Crane Load Stability Test

SAE J874, Center of Gravity Test Code.

SAE J987, Crane Structure, Method of test.

Underwriters' Laboratories

UL 558, Internal-Combustion-Engine-Powered Industrial Trucks.

UL 583, Electric-Battery-Powered Industrial Truck

PREPARED BY: ASHRF AL MGHRBL
EHS CONSULTANT



Petro HSE

@petro.hse

CALL NOW



SEND...



Like



Follow



Send Email



Save