



LEEA Academy

Developing Professionals for the Lifting Equipment Industry

Lifting Equipment General (LEG)

Training Course Step Notes

1



LEEA Learning and Development Agreement

In the interests of all parties and to support the successful achievement of the LEEA Lifting Equipment General Diploma, the following arrangements are to be confirmed:

Student:

I agree to:

- Follow the instructions of my LEEA training facilitator at all times
- Follow all rules and procedures regarding health and safety matters whilst on site
- Respect the tidiness and cleanliness of training areas and rest area facilities
- Notify my LEEA training facilitator immediately if I have any concerns
- Inform my LEEA training facilitator of any learning difficulties at the soonest opportunity (this may be done privately between you and your LEEA training facilitator)
- Keep to agreed session times and return from rest breaks and lunchtime periods in a timely fashion
- Keep my mobile phone on “silent” for the duration all training sessions and to leave the class if I have to make or receive an urgent call, for the benefit of my fellow students
- Provide feedback to the LEEA facilitator regarding the training I have received
- Respect the opinions of my fellow students and to actively engage in group discussion
- Strictly adhere to the rules regarding LEEA Examinations.

Signed _____

2

Date _____

LEEA Training Facilitator

I agree to:

- Safeguard the health, safety and welfare of my students throughout the training programme
- Provide my students with quality training, maintaining the highest of professional standards throughout
- Maintain confidentiality for all students at all times
- Provide regular feedback to students on their progress, identifying areas which may need additional study
- Keep appropriate records of any assessments conducted
- Ensure that all students are able to discuss any issues or concerns which may arise during the training course

Signed _____

Date _____

Disclaimer

These Step Notes are a useful and authoritative source of information for the lifting accessories (LEG) examiner.

Whilst every effort has been made to achieve the highest degree of accuracy in the generation of the data and information supplied, ultimate responsibility remains with the person and their organisation to ensure that current legal requirements are followed.

All stated legislative documents, regulations and standards are representative of the currently available version. Particular versions are stated with their respective release dates where necessary.

First EditionSeptember 2015

All rights reserved. No part of this publication may be reproduced, stored in a retrieval system or transmitted in any form or by any means, without the prior written permission of the Lifting Equipment Engineers Association.

Contents:

- | | |
|--|------------------------------------|
| 1. Legislation | 10. Textile Roundslings |
| 2. Heat Treatment | 11. Shackles and Eyebolts |
| 3. Stress and Strain | 12. Rigging Screws and Turnbuckles |
| 4. Verification of Lifting Equipment | 13. Plate Clamps |
| 5. Components for slings | 14. Clamps |
| 6. Chain and Chain Slings | 15. Lifting Beams |
| 7. Wire Rope and Wire Rope Slings | 16. Lifting Magnets |
| 8. Textiles Slings – Fibre Rope Slings | 17. Vacuum Lifters |
| 9. Textile Webbing Slings | 18. Crane Forks and 'C' Hooks |
| ** Revision Test 2 ** | ** Revision Test 2 ** |

Legislation



Moral, Legal and Financial reasons for Health and Safety Legislation

- Employers have a moral responsibility to ensure appropriate working conditions are provided
 - This is known as a common law duty of care
- Unsafe working conditions are likely to have an impact on production
 - Loss of output leading to lowering of morale and motivation
 - Loss of sales turnover and profitability
- Society and customer expectations of a company's approach to managing safety – health and safety culture
 - Negative PR would have a damaging effect on any business
- Financial cost from loss of output
 - Fines, damages, legal costs, insurance etc.

4

Legislation

- Satisfy the need for common requirements throughout Europe
- To ensure that European Directives are implemented
- Main European Directives are already regulations in the UK
- Most countries in the European Free Trade Area have similar laws
- There are 2 types of Directives:
 - Those that remove barriers to trade
 - Those that concern health and safety
- Lifting equipment legislation calls for:
 - Requirements for design
 - Condition of the equipment
 - The manner in which it is used

- Health and Safety at Work etc. Act introduced in 1974:
 - Covers all work situations
 - Ensure safety of people at work
 - Goal setting: aims and achievements to be met are given
 - Does not specify how to achieve aims and achievements

Legislative Structure of Health and Safety

- Primary legislation sets out governing principles
- Establishes an agency to enforce them, e.g. the HSE in the UK
- Subordinate legislation or regulations deal with particular industries and associated codes of practice - clarifying the standards to which entities must work



In the UK the Health and Safety at Work etc. Act 1974 is supported by LOLER and PUWER Regulations 1998 and their respective Approved Codes of Practice (L113 LOLER, L22 PUWER)

What is the main purpose of the Health and Safety at Work etc. Act?

The Health and Safety at Work Act covers nearly all occupations. It is designed to protect people at work including staff, visitors, contractors and members of the public. The HSWA supersedes nearly all of the previous health and safety laws in the UK.

The main purposes of the Act are set out in section 1 as follows:

- To secure the health, safety and welfare of persons at work
- To protect other people from hazards arising from work
- To control the keeping and use of dangerous substances and materials, including explosives and highly flammable materials
- To control the emission of noxious substances from certain premises
- It sets out a framework of general duties, primarily on employers, but also on employees and the controllers of premises, and on designers, manufacturers, importers and suppliers in relation to articles and substances used at work

Regulations from the Act

Regulations are one form of delegated legislation made possible by Section 15 of HSWA which gives powers to the Secretary of State (UK) to make regulations for matters concerned with health and safety at work.

Regulations are not Acts of Parliament but do have the support of the law and therefore must be complied with.

Regulations are increasingly drafted by reference to European Directives (these will be discussed at a later stage in this module).

There are many sets of regulations applying to health and safety. Some apply to all places of work and others are specific to particular industries, operations, substances, materials or premises. Here are some examples of such Regulations:

- The Manual Handling Operations Regulations
- The Control of Substances Hazardous to Health Regulations

Duty of Care

Employer and employee have a common law duty of care to each other and to other employees.

Health and Safety at Work Act Section 2

Employers' General Duty:

"Duty to ensure so far as is reasonably practicable, the health, safety and welfare at work of all his employees"

- Safe plant and systems of work
- Safe use, handling, storage and transportation of articles and substances
- Information, instruction, training and adequate supervision (I.I.T.S.)
- Safe place of work and a safe means of access and egress
- Safe working environment and adequate welfare facilities

Notes:

Health and Safety at Work Act Section 6

Specific duties on designers, manufacturers, importers and suppliers:

- Ensure that articles they design, construct, make, import, supply etc. are safe and without risk to health at all times
- Carry out or arrange such testing and examination necessary
- Ensure end users have adequate information about its designed and tested use including essential conditions for dismantling and disposal
- Ensure that customers are given updated information where it becomes known that the item gives rise to serious risk to health and safety

Health and Safety at Work Act Section 7

Duty of Employees at Work:

- Must not endanger themselves, or others, by their acts or omissions
- Must co-operate with their employers

7

Management of Health and Safety at Work Regulations

In addition to Section 2 (2) c of the HSWA, The Management of Health and Safety at Work Regulations require employers to ensure the effective planning, organisation, control, monitoring and review of preventive and protective measures. All these arrangements must be recorded and made known to employees. This is usually accomplished by the design of a company health and safety policy.

MHSWR underlines the requirements for employers to provide instruction and training.

Employers must ensure that their personnel are properly trained to use any equipment necessary in the course of their work, but the regulations also place an obligation on employees to undergo such training and follow the instructions given by their employer.

Operatives are required to only use equipment for which they are trained and to use it in the manner and for the purpose for which they have been trained.

The Competent Person (LEEA Definition)

The term 'Competent Person' has long been used in legislation. Current legislation uses it for a variety of duties to describe a person with the necessary knowledge, experience, training, skill and ability to perform the specific duty to which the requirement refers. There can therefore be several 'Competent Persons', each with their own duties and responsibilities, i.e. competent for the purpose.

The term has never been fully defined in law but, for the purpose of thoroughly examining lifting equipment, the LEEA definition of a Competent Person is a person having such practical and theoretical knowledge and experience of the equipment which is to be thoroughly examined that will enable him/her to detect defects or weaknesses which it is the purpose of the examination to discover and assess their importance to the safety of the equipment. The Competent Person should have the maturity to seek such specialist advice and assistance as may be required to enable him/her to make necessary judgements and be a sound judge of the extent to which he/she can accept the supporting opinions of other specialists. He/she must be able to certify with confidence whether it is free from patent defect and suitable in every way for the duty for which the equipment is required. It is the view of LEEA that competency can be a corporate responsibility.

Primary Elements of Competency

I – Information

I – Instruction

T – Training

S – Supervision

Important Note:

LEEA training course certificates and diploma qualifications are not evidence, declaration or proof of competency.

Only use equipment in the way you have been trained to use it!

Risk Assessment

The 3 main reasons to assess and manage risk:

- Human harm
 - Injury and illness
- Legal Effects
 - Duty of care and consequences of unsuitable or insufficient risk management
- Economic effects
 - Substantial financial costs are related to accidents at work

Firstly, we have to consider the factors that contribute to accidents / ill-health in the workplace:

HAZARD, DANGER, LIKELIHOOD, SEVERITY, RISK

- Hazard?
 - A hazard is something (object or situation) that has the potential to cause harm
- Danger?
 - A liability or exposure to harm; something that causes peril
- Likelihood?
 - How likely it is that someone could be harmed by the hazard
- Severity?
 - If the potential for harm was to occur, how severe would the accident be?
- Risk? (a combination of likelihood and severity)
 - Risk is the likelihood that the harm from the hazard is realised

NET RESULT (Risk) = Likelihood x Severity, i.e. how likely x how severe the consequence.

5 Steps to Risk Assessment

- Identify the hazards
- Decide who might be harmed and how
- Evaluate the risks and decide on **control measures**
- Record your findings and implement them
- Review your assessment and update if necessary

Control Measures

- Eliminate
- Reduce
- Isolate
- Control
- PPE
- Discipline

Monitor and Review

Ensure control measure compliance (discipline).

Be vigilant - note changes: additional hazards presented? Example: traffic, pedestrians etc., changes in production activity.

Record your findings and change the risk assessment as necessary. This may result in the requirement for additional control measures

Are you following a Safe System of Work?

- ✓ You have evaluated the hazards
- ✓ You have identified who may be harmed
- ✓ You have decided upon and implemented control measures
- ✓ You have recorded your findings
- ✓ You will review and monitor the situation

Notes:

The European Machinery Directive

A European Directive is a Directive to the member states of the European Community, which has been adopted by the Council of Ministers, to introduce legislation with common requirements throughout the Community. The Directives are used to remove barriers to trade and introduce common safety requirements.

The Machinery Directive is largely based on Risk Assessment and use of EU Standards for critical features such as guards and emergency stops. Machinery Directive - provides the harmonisation of the **Essential Health and Safety Requirements (EHSRs)** for machinery.

It applies only to products that are intended to be placed on or put into service in the market for the first time.

Machinery: *"an assembly, fitted with or intended to be fitted with a drive system other than directly applied human or animal effort, consisting of linked parts or components, at least one of which moves, and which are joined together for a specific application".*

Manufacturer is responsible for verifying whether a particular product falls within the scope of the Machinery Directive.

Note: The definition here is for 'Machinery' within the scope of the directive in the 'strict' sense, but the directive also has other definitions covering machinery in the 'broader' sense. The strict sense definition excludes manual lifting machines, accessories, ropes, chains and webbing. All of which are covered by the broader sense definitions.

11

Machinery Directive is implemented in the United Kingdom under the Supply of Machinery (Safety) Regulations:

The Supply of Machinery (Safety) Regulations 2008, SI No 1597 implement the Machinery Directive and contain essential safety requirements which the machinery, including lifting machines and lifting accessories, must meet.

Manufacturers, importers (into the European Union) and suppliers placing such equipment on the market for service in the community have a duty to:

- Design, build and supply equipment that is safe and meets the Essential Safety Requirements
- To carry out such tests as may be necessary to ensure the requirements of above are met
- To maintain records of all calculations, tests and other relevant information that go to make up a **Technical File** which may be called upon by the enforcing authorities and which must demonstrate that the Essential Safety Requirements have been met
- Issue with each item of equipment information on the installation, maintenance, care and safe use, and:
- Issue a Declaration of Conformity and affix the CE mark, or issue a Declaration of Incorporation depending on its nature and intended use. In this context, if you manufacture or import (from outside the European Union) an item for your own use, you assume the full responsibilities of the manufacturer and must therefore meet all of the requirements of the Regulations

To support the Machinery Directive, the Joint European Standards Organisation, CEN/CENELEC, has been producing Harmonised European Standards.

Most of these standards have been published but there are still some left in the pipeline. As and when they are published, they will supersede any existing British Standards or other European national standards covering the same products.

These Harmonised Standards have a special status in that products made to the standard are deemed to meet the essential health and safety requirements of the relevant Directives, and therefore the UK Regulations, in so far as the standard addresses such essential requirements.

They therefore provide a relatively easy way for manufacturers to know that their products meet the legal requirements and equally a convenient way for purchasers to specify their needs.

Following the publication of the new Machinery Directive 2006/42/EC in 2006, all the relevant Harmonised Standards have been amended to make reference to it.

The Technical File

A list of the Essential Health and Safety Requirements that apply to the lifting equipment; a description of the methods used to eliminate these hazards or reduce risks; the standards used in the design; information from the user; design information (calculations, drawings, procedures, etc.); material traceability; tests reports and instructions for use for use.

What is a machine?

"An assembly, fitted with or intended to be fitted with a drive system other than directly applied human or animal effort, consisting of linked parts or components, at least one of which moves, and which are joined together for a specific application".

Note: As an example, a manual slew jib without hoist would not be within the scope of the Directive.

Aligned to the requirements of the Machinery Directive, the Supply of Machinery (Safety) Regulations state that lifting equipment must be designed and built to sustain a static overload of:

Manually operated machines	1.5 x WLL
Other machines	1.25 x WLL
Lifting accessories	1.5 x WLL

Machinery must be capable of sustaining a dynamic overload of:-

$$1.1 \times WLL$$

Previous standards and directives have used different values therefore it is important to always consult manufacturers' documentation for specific requirements.

- Lifting machines must also be supplied with instructions for:-
- Care and safe use
- Installation, commissioning and testing

- Maintenance and adjustments
- Limitations of use and possible misuse
- Noise and vibration emissions
- Training

PUWER and LOLER

PUWER: Provision and Use of Work Equipment Regulations
(Applies to all work equipment)

LOLER: Lifting Operations and Lifting Equipment Regulations
(Applies to lifting equipment in addition to PUWER)

These are **legal requirements** in the UK.

Internationally these are **good practice** demanded by customers and local authorities and are integral to the **LEEA Code of Practice**.

The Essentials of PUWER

PUWER places duties on the employer to ensure that:

- It is the duty that the employer to ensure that work equipment coming into his undertaking meets with any EHSRs and in the case of lifting equipment this would be of directive 2006/42/EC.
- Work equipment is suitable for the purpose for which it is to be used
- The working conditions and risk to health and safety of personnel in which the work equipment is used is to be considered
- Equipment is suitably maintained and a log kept up to date
- Equipment is inspected on a regular basis (ref. LOLER)
- All inspection and maintenance records are kept and recorded
- All persons using work equipment have sufficient information pertaining to its use, e.g. operating manuals and guides to safe use

PUWER requires employer to address risks or hazards of equipment from all dates of manufacture and supply.

Equipment first provided for use after 31st December 1992 must comply with any '**essential requirements**'

Equipment may still present a hazard or risk if:

- Application different from that originally envisaged
- Safety depends upon the way it is installed
- Technical mismatch between the supply side and user side legislation

Employers can ensure compliance by checking:

- CE marking
- EC declaration of conformity

PUWER requires that, when providing equipment for use at work:

The purchaser obtains equipment complying with the relevant European Directives.

E.g. In the case of grade 8 mechanically assembled chain slings, specifying BS EN 818-4 and requesting the EC Declaration of Conformity will ensure that the slings meet this requirement.

PUWER Key Regulations

- Regulation 4: Suitability of work equipment
- Regulation 5: Maintenance
- Regulation 6: Inspection
- Regulation 7: Specific risks
- Regulation 8: Information and instructions
- Regulation 9: Training

Notes:

Lifting Operations and Lifting Equipment Regulations (1998)

Applicable to all areas of industry within GB including offshore installations.

Covers existing used leased and new equipment.

Lifting Operation:

An operation that includes lifting and lowering of a load. The 'load' includes people.

Lifting Equipment:

Any work equipment used for lifting or lowering loads and includes attachments used for anchoring, fixing or supporting it.

LOLER Key Regulations

- Regulation 4: Strength and stability
- Regulation 5: Lifting equipment for lifting persons
- Regulation 6: Positioning and installation
- Regulation 7: Marking of lifting equipment
- Regulation 8: Organisation of lifting operations
- Regulation 9: Thorough examination and inspection
- Regulation 10: Reports and defects
- Regulation 11: Keeping of information

15

Regulation 4: Strength and stability

Employers must ensure that:

- Lifting equipment is of adequate strength and stability for each load, particularly when stress may be induced at mounting or fixing points
- Every part of a load and anything attached to it and used in lifting is of adequate strength

Regulation 5: Lifting Equipment for Lifting Persons

- Details the additional safeguards that must be considered when using lifting equipment to lift people

Regulation 6: Positioning and Installation

- Details the considerations on where lifting equipment, both fixed and mobile equipment, should be sited

Regulation 7: Marking of lifting equipment

- All lifting equipment to be marked with its SWL and information that gives the items characteristics, e.g. boom length, radius, capacity (load charts) etc.

Regulation 8: Organisation of Lifting Operations (Refer to Standard BS 7121)

- Must be planned by a competent person
- Must be supervised
- Must be carried out in a safe manner

Regulation 9: Thorough Examination and Inspection

Before lifting equipment is put into service for the first time it is thoroughly examined for any defect unless the lifting equipment:

- Is less than 12 months old
- Owner holds the original DOC
- Equipment that has not been used before will require thorough examination when entering service if the DOC is older than 12 months. Equipment can be damaged during long periods within the supply chain.

Maximum fixed periods for thorough examinations and inspection of lifting equipment are: -

- **Lifting accessories 6 months**
- **Lifting equipment..... 12 months**
- **People Carrying Equipment 6 months**

The information to be contained in the report of thorough examination is given in schedule 1 of LOLER.

Written Scheme of Examination

The Lifting Operations and Lifting Equipment Regulations 1998 permits a scheme of examination, drawn up by a competent person, as an alternative to the fixed maximum periods.

The benefit of an examination scheme is that, by focusing on the most safety critical areas, the examinations can be carried out the most cost effective way. This may provide a means of reducing examination costs, however it may also provide a means of enhancing safety without increasing costs.

The written scheme of examination should contain at least the following information:

- The name and address of the owner of the lifting equipment
- The name and contact details of the person responsible for the equipment. If responsibility is divided, e.g. between maintenance and operations, there may be more than one name. However it should be clear who should be notified in the event of a dangerous or potentially dangerous defect and to whom reports should be sent
- The name, qualifications and address of the person drawing up the scheme. If the competent person is not working on their own account, the name of their employing organisation and their position in that organisation should be given
- The identity of the equipment, i.e. a description including the make, model and unique identity number
- The location of the equipment if it is a fixed installation or the location where it is based for portable and mobile equipment
- Details of any information or references used in drawing up the scheme. For example the manufacturer's manual, expected component life, or specific information on the design life of the crane structure and mechanisms as detailed in clause 7 of ISO 12482-1
- The basis for the scheme. For example, is it based on hours of service, duty monitoring, examining certain parts or components at different intervals to other parts?
- Details of any data logging system fitted, including a list of the parameters monitored and the means of data retrieval, monitoring and storage
- What determines when the thorough examination shall take place and who is responsible for monitoring that and instigating the examination?
- Identification of the safety critical parts requiring thorough examination
- A risk assessment. This should take account of:
 - The condition of the equipment
 - The environment in which it is to be used
 - The number and nature of lifting operations and the loads lifted
 - It should include details of any assumptions about usage, expected component life etc.

- The frequency of thorough examination of those parts identified as safety critical taking into account the degree of risk associated with each part. This may include time or loading or duty cycle limits and vary for different parts of the equipment. Where the scheme is based on such criteria, we recommend that a maximum period between thorough examinations is always specified as equipment can deteriorate whether used or not
- The method of examination of those safety critical parts, which may include the degree of dismantling required and the techniques employed e.g. visual examination, measurement, NDT, operational test, load test
- The rejection criteria or a reference to where this information may be found
- An indication of the resources required to prepare the equipment and carry out the thorough examination. This may include qualified personnel, workshop facilities, specialist NDT and metallurgical facilities
- Any changes to equipment condition, operational or environmental parameters that will require a review of the scheme by the competent person. These may include damage to the equipment, change of use from general duty to heavy duty or moving from an inland location to a marine environment
- A requirement for the person responsible for the equipment to monitor its circumstances of use and inform the competent person who drafted the scheme of any changes
- The date of drawing up the scheme and the date at which any routine review is required

Further information on written schemes of examination can be found in the LEEA COPSULE Edition 8 Appendix 1.8

Regulation 10: Reports and defects

A person making a thorough examination for an employer under regulation 9 shall:

- Notify the employer immediately of any defect in the lifting equipment which in his opinion is or could become a danger to persons
- As soon as is possible, make an examination report in writing authenticated by him or on his behalf by signature or equally secure means and containing the information specified in Schedule 1 to the employer
- Where there is in his opinion a defect in the lifting equipment involving an existing or imminent risk of serious personal injury, send a copy of the report as soon as is possible to the relevant enforcing authority. In this case, an employer who has been notified of an imminent risk shall ensure that the lifting equipment is not used before the defect is rectified

Regulation 11: Keeping of information

An employer obtaining lifting equipment shall:

- Keep the EC declaration of Conformity for so long as they operate the lifting equipment
- Ensure that the information contained in every report is kept available for inspection

In the case of a thorough examination for lifting equipment:

- Until he ceases to use the lifting equipment

In the case of a thorough examination for lifting accessories:

- For two years after the report is made

LOLER and the Tester/Examiner

LOLER refers to 'Thorough Examination and Inspection' – of which a test may be part.

A Report of Thorough Examination to include details of any tests carried out.

The duties of the Competent Person include ensuring that:

- Lifting equipment has been thoroughly examined before it enters service
- Second-hand, hired or borrowed equipment has a current examination report before it is used
- And, where safety of equipment depends upon installation:
 - That it has a thorough examination after it has been installed
 - That it has a thorough Examination after it has been assembled

Notes:

Manual Handling Operations Regulations

These refer directly to lifting operations and add to the employers duties in Section 2 of the HSWA.

Requires an assessment to be made of any operation where loads are handled manually, or where manual effort is necessary, with a view to reducing the number of injuries that result from such operations:

- Task
- Individual
- Load
- Environment

Requires the introduction of lifting appliances where the risks are high or if the operation can be made safer by their introduction.

Working at Height

The danger of people and materials falling affects not only those working at height, but also, and sometimes to a greater degree, those underneath.

Working at height is one of the biggest causes of fatalities and major injuries. Commonly, accidents are caused from falls from ladders and through fragile surfaces.

Work at height means work in any place where, if there were no precautions in place, a person could fall a distance that could cause personal injury (for example a fall through a fragile roof).

Employers and those in control of work at height must first assess the risks.

Before working at height you must follow these simple steps:

- Avoid work at height where it is reasonably practicable to do so
- Where work at height cannot be easily avoided, prevent falls using either an existing place of work that is already safe or the right type of equipment
- Minimise the distance and consequences of a fall, by using the right type of equipment where the risk cannot be eliminated

The Work at Height Regulations have an influence on lifting practice. They emphasise the need to avoid working at height if possible but, where it is necessary, they require the most suitable means of reducing and controlling the risk.

Consequently this has affected the choice of equipment for some lifting operations.

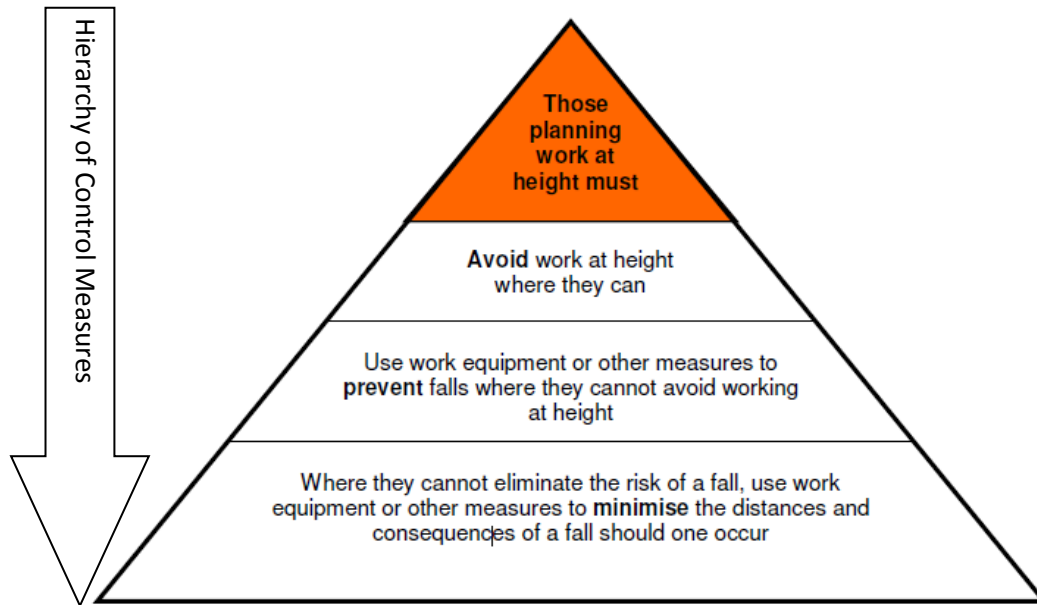

Dos and Don'ts of Working at Height

Do:

As much work as possible from the ground.

Ensure workers can get safely to and from where they work at height.

Ensure equipment is suitable, stable and strong enough for the job, maintained and checked regularly.

Take precautions when working on or near fragile surfaces.

Provide protection from falling objects.

Consider emergency evacuation and rescue procedures.

Don't:

Overload ladders – consider the equipment or materials workers are carrying before working at height. Check the pictogram or label on the ladder for information.

Overreach on ladders or stepladders.

Rest a ladder against weak upper surfaces, e.g. glazing or plastic gutters.

Use ladders or stepladders for strenuous or heavy tasks, only use them for light work of short duration (a maximum of 30 minutes at a time).

Let anyone who is not competent (who doesn't have the skills, knowledge and experience to do the job) work at height.

Revoked, Repealed and Amended Legislation

Prior to 5 December 1998, the Factories Act 1961 was the main legislation concerned with the use of lifting equipment and it was augmented several sets of industry specific regulations. The Provision and Use of Work Equipment Regulations 1998 and the Lifting Operations and Lifting Equipment Regulations 1998 together repeal, revoke or amend and replace the requirements for lifting equipment given in the following:

The Factories Act 1961

- The Construction (Lifting Operations) Regulations 1961
- The Shipbuilding and Ship-repairing Regulations 1960
- The Docks Regulations 1988
- The Mines and Quarries Act 1954
- The Offshore Installations (Operational Safety, Health and Welfare) Regulations 1976
- The Lifting Plant and Equipment (Records of Test and Examination etc.) Regulations 1992.

Notes:

Heat Treatment

Although nearly all items of lifting gear are heat treated, the processes involved will be unfamiliar to the vast majority of lifting equipment examiners.

Heat treatment is a process that will have been carried out by the manufacturer long before an item arrives at the tester and examiners workplace. Even so it is an important process to us in many ways and its failure can have catastrophic results.

Steels used to manufacture lifting equipment are usually within a small range of carbon steels, with a maximum content of 0.35% carbon, and a few relatively simple alloy steels. These generally behave in the same way during the limited forms of heat treatment we apply.

Reasons for Heat Treatment

There are two main reasons for heat treating lifting equipment:

- To remove defective structures that may have developed during working, e.g. forging, welding etc.
- To improve the properties of the material, increase the strength, hardness, ductility and toughness

Heat Treatment is performed to improve the properties of a given material.

Steel is basically an alloy of ferrite (pure iron) and carbon, other elements may be then added to give the final material certain properties and characteristics.

The steel is made up of grains and we change the grain microstructures by the application of heat.

When a piece of steel is worked, i.e. bent, burnt, forged, welded etc, stresses are set up between the grains and alter their shape. Using heat treatment we can correct the damage we have done by relieving those stresses and returning the grain to its desired shape.

We can also change the size and structure of the grains to obtain the most suitable qualities to suit the duty to which the steel is being put.

Improving Material Properties

Steels containing more than 0.25% carbon, and alloy steels, can have their properties, such as strength, hardness, toughness and ductility, greatly improved by suitable heat treatment. Standards for lifting equipment and chain, e.g. eyebolts to BS EN ISO 3266 and chain to BS EN 818 etc., call for the finished product to be hardened and tempered.

When hardening and tempering, a wide range of properties can be achieved by controlling the tempering temperature.

A low temperature will cause the finished steel to be hard and strong, but brittle, whereas a high temperature will produce a tough steel that is softer and less strong.

Heat Treatment Definitions

Austenite - this is a solid solution of iron and carbon. In the way that salt will dissolve in water, carbon will dissolve in iron but; as this happens well below the melting point it is known as a 'solid solution'.

Pearlite - a layered structure of iron carbide and iron.

Ferrite - pure iron.

Martensite - an unstable structure with needle shaped crystals. It is highly stressed, very hard and brittle.

What happens to a piece of steel when it is heated?

When raised to a temperature above A3, the carbon dissolves into the iron and forms Austenite.

The 2 stages to this change of microstructure are known as the Critical Points.

Lower critical point = A2

Higher critical point = A3

A2 is where Austenite begins to form.

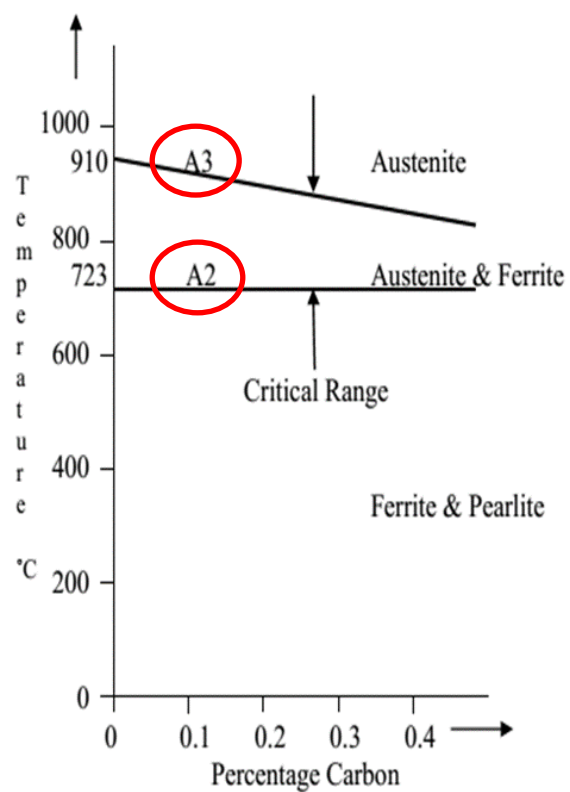
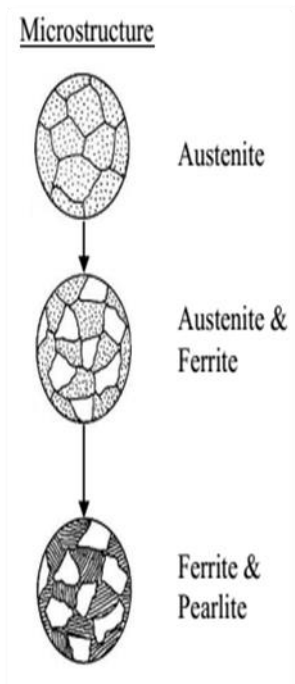

The stage between A2 and A3 is known as the Critical Range. During this range, the microstructure is composed of Austenite and Ferrite.

Below A2, the microstructure is composed of Ferrite and Pearlite.

The grain size affects the mechanical properties of the steel; the smaller the grain the stronger and tougher the steel.

When the steel is heated to just above the A3 point small grained Austenite is formed, but as the temperature is increased the grains begin to grow.

At a certain point, when excessive heat is applied, the grains will begin to melt and the steel will become burnt and unusable.

If the heated steel is allowed to cool slowly from the Austenite condition, the grain size will remain the same as it attained at the highest temperature.

At the A3 point the remaining Austenite changes to Pearlite, the grain size remaining unaltered.

The speed at which the steel is cooled determines the final grain structure.

Rapid cooling by quenching in water or oil tends to freeze the structure. In the case of the most rapid cooling, Austenite cannot change to Pearlite and Ferrite and an unstable structure known as Martensite is formed.

Steel in this hardened condition is of little practical value, and it needs to be tempered to give it toughness (it will be very brittle).

By reheating the hardened steel, but to a lower temperature, the internal stresses can be removed and the structure modified so that small grains remain. This is known as tempering.

During tempering, the steel loses some of its hardness and regains a considerable degree of toughness and ductility, the proportions of which are determined by the temperature reached and the duration of the heating. The tempering operation requires accurate temperature control and timing, as slight variations considerably affect the result.

If steel has been freshly ground, sanded, or polished, it will form an oxide layer on its surface when heated.

As the temperature of the steel is increased, the thickness of the iron oxide will also increase.

Although iron oxide is not normally transparent, such thin layers do allow light to pass through, reflecting off both the upper and lower surfaces of the layer. This causes a phenomenon called thin-film interference, which produces colours on the surface.

As the thickness of this layer increases with temperature, it causes the colours to change from a very light yellow, to brown, then purple, then blue. These colours appear at very precise temperatures, and provide the blacksmith with a very accurate gauge for measuring the temperature.

Tempering

The various colours, their corresponding temperatures, and some of their uses are:

- Faint-yellow – 176 °C (349 °F) – engravers, razors, scrapers
- Light-straw – 205 °C (401 °F) – rock drills, reamers, metal-cutting saws
- Dark-straw – 226 °C (439 °F) – scribers, planer blades
- Brown – 260 °C (500 °F) – taps, dies, drill bits, hammers, cold chisels
- Purple – 282 °C (540 °F) – surgical tools, punches, stone carving tools
- Dark blue – 310 °C (590 °F) – screwdrivers and spanners
- Light blue – 337 °C (639 °F) – springs and wood-cutting saws
- Grey-blue – 371 °C (700 °F) and higher – structural steel

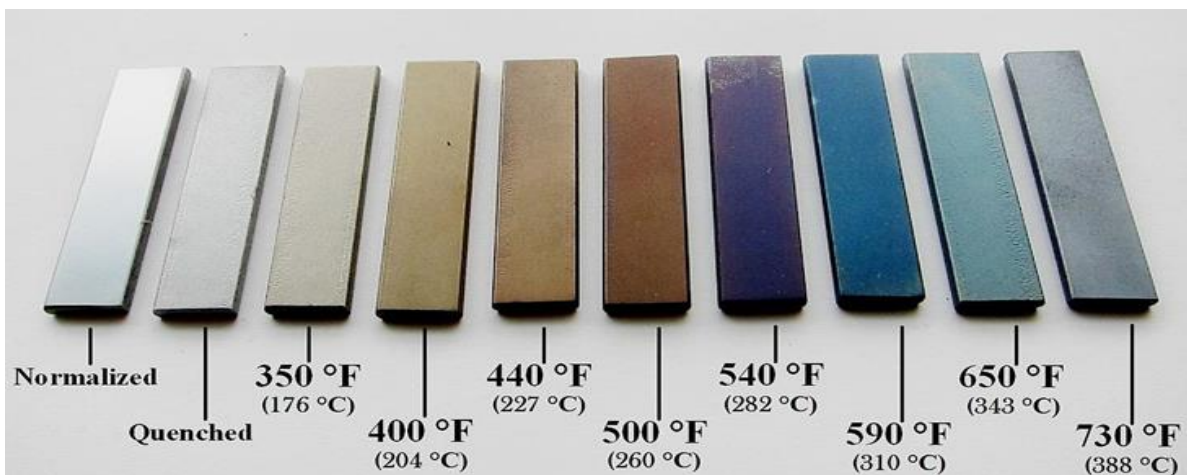

Notes:

Normalising

Only a limited range of small fabricated items of lifting equipment items are normalised, but it is worthwhile understanding the requirements.

Applied to some, but not all, engineering steels, normalising can soften, harden or stress relieve a material, depending on its initial state.

The objective of the treatment is to counter the effects of prior processes, such as casting, forging or rolling, by refining the existing non-uniform structure into one which enhances machinability/formability or, in certain product forms, meets final mechanical property requirements.

A primary purpose is to condition the steel so that, after subsequent shaping, a component responds satisfactorily to a hardening operation (e.g. aiding dimensional stability).

Normalising is a process of heating suitable steels to a temperature typically in the range 830-950°C (at or above the hardening temperature of hardening steels) and then cooling in air.

Hardening and Tempering

The hardening process is similar to normalising except that at the end of the soak time the equipment is immediately quenched in water or oil.

Tempering takes place immediately after quenching. The equipment is reheated to a temperature between 550°C and 660°C for mild steel and higher tensile steels, and between 500°C and 600°C for alloy steel, the soaking period is between 6 and 8 minutes for every 3mm depth, the equipment is then allowed to cool naturally in still air. The temperature chosen depends on the required hardness, the lower the tempering temperature the harder the result.

From the above it can be seen that, if a piece of heat treated lifting equipment is used to lift items of high temperature, or in hot conditions, care is needed to ensure that the equipment does not become subjected to temperatures of, or above, the tempering temperature otherwise the lifting equipment will become softened. Where such heating has occurred the lifting equipment should be removed from service.

Manufacturing Defects

Forging

A lot of lifting equipment is made by forging. In order to be able to work the material, this process is carried out with the steel heated to well above the A3 point. As a result the structure is coarse. As the metal is worked the grains are broken down as the metal cools. The forging process usually finishes well above the A3 point resulting in a coarse grain structure. If the temperature drops too low, residual stresses are set up in the material. Normalising or hardening and tempering can correct both these conditions.

Welding and Flame Cutting

Produces a coarse grain structure and increased brittleness due to heat transfer. This can also be corrected by normalising or hardening and tempering. Small fabrications are often normalised but in the case of larger fabrications made from rolled steel sections of welding quality (e.g. spreader beams) heat treatment is not considered necessary as the material composition and size is such that harmful effects are minimised.

Steel that has been overheated and burnt during a manufacturing process will be subject to decarburization these faults cannot be remedied by heat treatment and the item can only be rejected as scrap.

Cold Worked Steel

Usually performed to make small pressed and bent items. They are often annealed during the production stages to prevent stress cracking and to enable them to be further worked.

Checking Heat Treatment

The heat treatment gives the lifting component its required mechanical properties. It is important that the treatment is carried out correctly as incorrect heat treatment can result in an item being too soft or too hard with eventual disastrous consequences.

As an incorrectly heat treated item will look no different from a correctly heat treated one, and may well sustain a proof load with no outward indications, manufacturers must verify that the correct heat treatment has been applied. Various methods of test have been developed to check the heat treatment:

- Hardness Testing
- Impact Testing
- Metallography

Hardness Testing

This is a non-destructive test that can be used very effectively to determine the accuracy of the heat treatment. There are various methods of hardness testing of which the following are the more commonly used:

- Vickers Hardness Test
- Rockwell Hardness Test
- Brinell Hardness Test

Of these tests, the Brinell Test is the most widely used by lifting equipment companies. It is an indentation method that presses an indenter into the metal. The diameter of the indentation is then measured and compared to a chart which gives the hardness number. The softer the material the greater the diameter of the indentation.

Brinell Testing

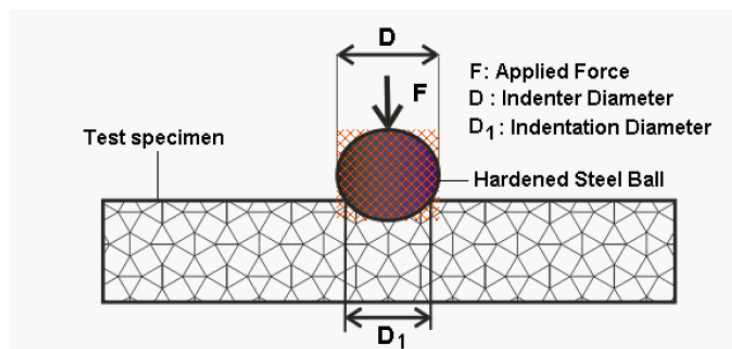

Checking Heat Treatment

Impact Testing

Impact Testing measures the toughness of a material by subjecting it to a shock load and measuring the energy absorbed. There are two basic tests, the Izod and the Charpy tests. Both use a notched specimen, which is hit by a knife-edge in a swinging pendulum. It is a useful test of successful heat treatment, since both normalising and tempering are carried out to give the material toughness. Hence, if the material is tempered at too low a temperature after hardening, this will be revealed in too low an impact value.

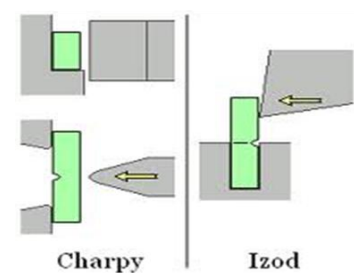

Metallography



This technique examines the heat treated material under a microscope to check the structure and composition of the component.

From the image so revealed, a metallurgist can determine the nature and extent of the heat treatment that has

been carried out on the bar. Although these may not mean very much to the untrained person, to the metallurgist, they reveal a great deal about the treatment the material has received.

It is not proposed to discuss the individual types of microstructure found, nor their appearance. This is best left to experts who are competent in metallurgy.

Notes:

Stress and Strain

Although lifting equipment examiners are not called upon to carry out stress calculations, and indeed they may not be qualified to do so, they do need to have an understanding of their effects on the equipment they are examining and may be testing.

Here we look at stress, strain and related matters as they affect lifting equipment and the methods of testing and the safe use.

Stress Terms

Stress is defined as force per unit area. It varies both with direction and with the surface it acts on.

- Tension Stress that acts to lengthen an object
- Compression Stress that acts to shorten an object
- Shear Stress that acts parallel to a surface. It can cause one object to slide over another

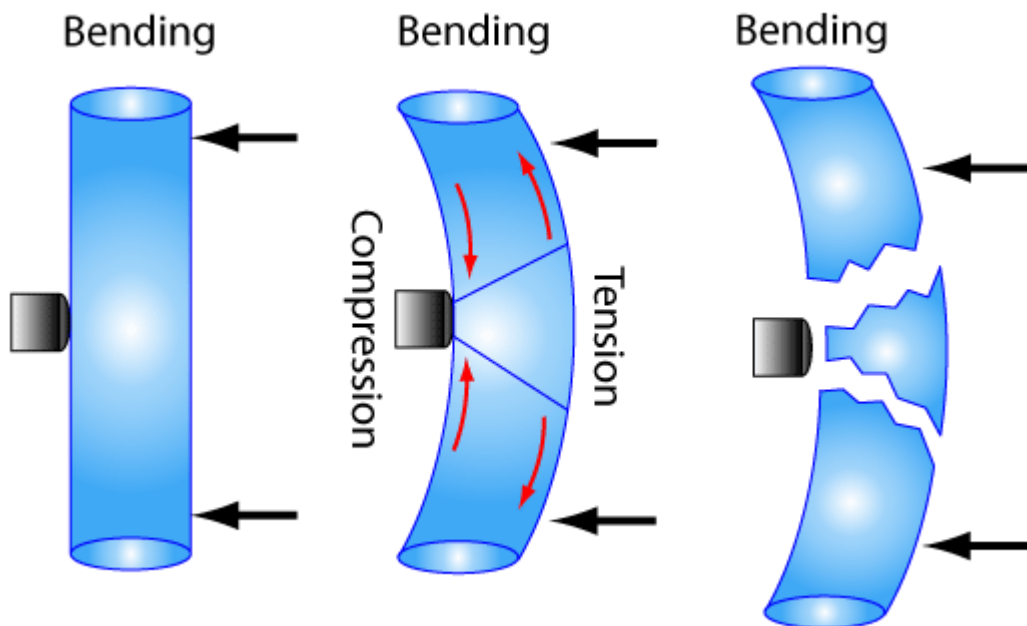

Strain Terms

Strain is defined as the amount of deformation an object experiences compared to its original size and shape.

Closely related, both being caused by an item being subjected to an applied force and when an item is subjected to a force the structure that makes up the material resist that force and this cumulative resistance is Stress.

$$\text{stress} = \text{load (Force)} \div \text{cross sectional area}$$

Stress is measured in N/mm^2 or MN/m^2 (Imperial unit of stress is tons/ins^2)

As the structure resists the applied force, i.e. come under stress, the structure deforms and this is called Strain.

$$\text{strain} = \text{change in length} \div \text{original length}$$

Strain is a ratio therefore it has no units.

Accepted conversion factors:

$$1 \text{ kg} = 10\text{N},$$

$$1 \text{ tonne} = 10\text{kN},$$

$$1 \text{ N/mm}^2 = 1\text{MN/m}^2$$

$$1 \text{ ton/inch}^2 = 15.44 \text{ MN/m}^2$$

$$1 \text{ lb/inch}^2 = 6.894 \text{ kN/m}^2$$

Hooke's Law

Metals obey this law while they are within the elastic deformation region and up to the proportional limit. This is the straight-line portion of the load/extension graph.

A solid body deforms when a load is applied to it. If the material is elastic, the body returns to its original shape after the load is removed. The material is linear if the ratio of load to deformation remains constant during the loading process. Not many materials are linear and elastic beyond a small amount of deformation.

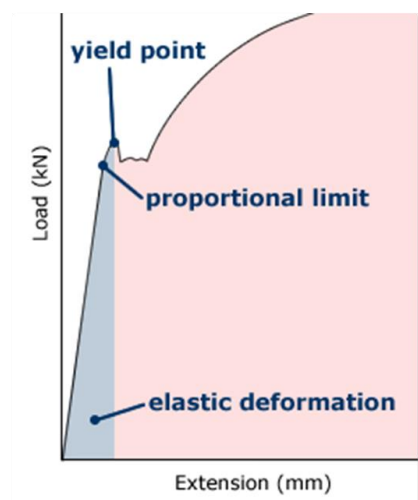

Young's Modulus

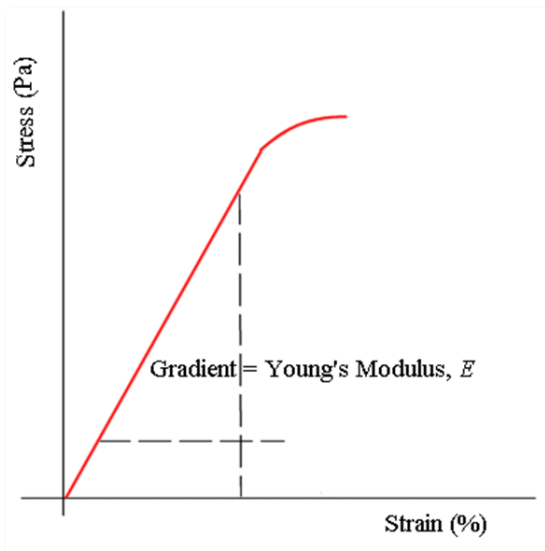

Young's Modulus (E) or the modulus of elasticity is a measure of a material's stiffness. The higher the Young's modulus value the stiffer the material. Young's Modulus can be calculated from tensile test stress/strain graphs—derived from load/extension graphs. The slope of the graph is used to calculate E when the material is obeying Hooke's law.

A constant Young's modulus applies only to linear elastic materials. A rigid material has an infinite Young's modulus because an infinite force is needed to deform such a material. A material whose Young's modulus is very high can be generally explained as rigid.

Elasticity, Hooke's Law and Young's Modulus

Many materials show a constant stress/strain relationship as loading is applied.

Hooke's Law states: 'Stress is proportional to Strain up to the Limit of Proportionality'.

$$\text{ie } \frac{\text{Stress}}{\text{Strain}} = \text{A Constant}$$

This ratio of stress and strain for a material, which shows this straight-line relationship of load extension, is known as **Young's Modulus of Elasticity**, denoted by symbol E.

$$\text{Hence } E = \frac{\text{Stress}}{\text{Strain}}$$

Modulus of elasticity for mild steel (E) = 200,000 MN/m². Value gives a relationship of the force to deformation within the elastic range of a material.

The greater the value of E the stiffer the material will be under load.

Stress Calculation – Example 1

In the bolted joint shown, if the force f is 6000 N and the bolt is 15 mm diameter, to the nearest whole number, what is the stress in the bolt?

$$\text{CSA of bolt} = \pi r^2 = 3.142 \times 7.5 \times 7.5 = 176.74$$

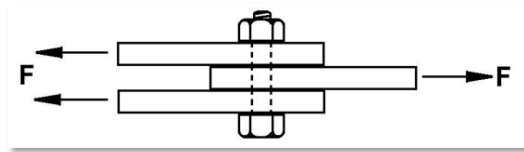

$$\text{Stress} = \frac{\text{Load (f)}}{\text{CSA}} = \frac{6000}{176.74 \times 2} = 353.48$$

Stress in bolt = 17N/mm² (16.97)

If a steel bar 10mm x 20mm is subject to a load of 50kN (50,000N), what is the stress in the bar?

$$\text{Stress} = \frac{\text{Load (f)}}{\text{CSA}} = \frac{50000\text{N}}{10 \times 20} = \frac{50000\text{N}}{200\text{mm}^2}$$

Stress = 250N/mm²

Stress Calculation – Example 2

In the pulley block shown, if the force F is 10000 N and the bolt is 15 mm diameter, to the nearest whole number, what is the stress in the bolt?

$$\text{CSA of bolt} = \pi r^2 = 3.142 \times 7.5 \times 7.5 = 176.74$$

(Where $\pi = \text{Pi}$ and $r = \text{radius}$)

$$\text{Stress} = \frac{\text{Load}}{\text{CSA}} = \frac{10000}{176.74 \times 2} = 353.48$$

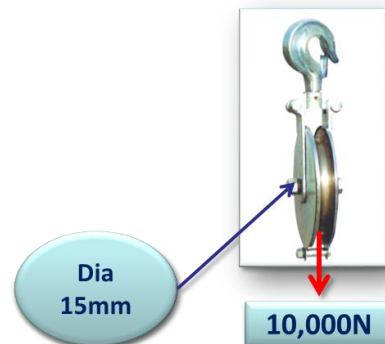

Stress in bolt = 28N/mm² (28.29)

Note: CSA has been doubled due to double shear loading

Where stress calculations use units of newtons (N) and metres (m) stress (σ) will be in units of Pascals (Pa)– $1\text{Pa} = 1\text{ N/m}^2$.

Where stress calculations use units of newtons (N) and millimetres (mm) stress (σ) will be in units of megapascals (MPa).

This can be very useful as most test specimens are measured in millimetres. Rather than converting to metres the measurements can be left in millimetres and the result will be in megapascals.

Pascals are the units for pressure. It measures the amount of force being applied over a given area.

The Tensile Test

The tensile test, also known as tension test, is probably the most fundamental type of mechanical test you can perform on material.

The tensile test reveals a great amount of information about the material and quantifies the important properties of the material. Lifting equipment examiners need to know these properties and how they are determined in order to understand various material specifications and relate these to their suitability for making lifting equipment.

A standard size specimen of the material to be tested is machined to a predetermined size. The cross section of the specimen is usually round, square or rectangular. For metals, a piece of sufficient thickness can be obtained so that it can be easily machined, a round specimen is commonly used. For sheet and plate stock, a flat specimen is usually used.

From the tensile test we can use the results to determine how a material will react under tensile loading. Typical properties revealed include the elastic limit, yield point, ultimate tensile strength and elongation/reduction in cross sectional area of the material under test.

What happens to a material under test?

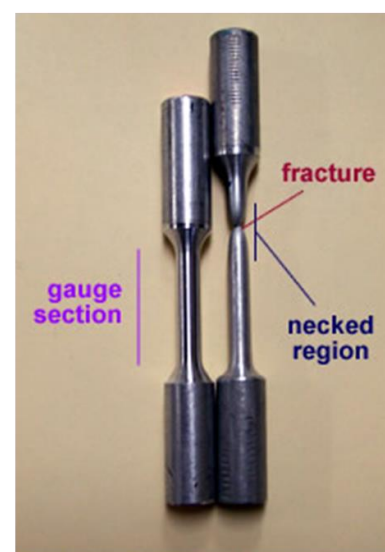
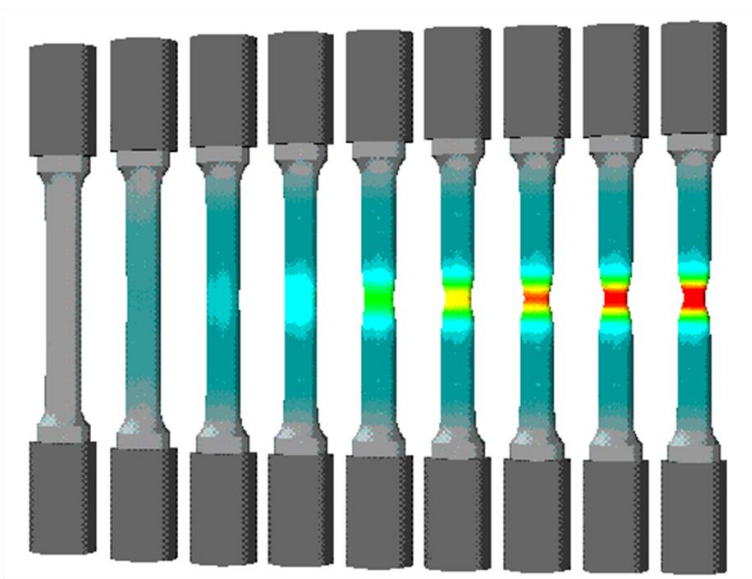

Tensile Test

A tensile load is applied to the specimen until it fractures.

During the test, the load required to make a certain elongation on the material is recorded. A load/elongation curve is plotted by a recorder so that the tensile behaviour of the material can be obtained. An engineering stress-strain curve can then be produced.

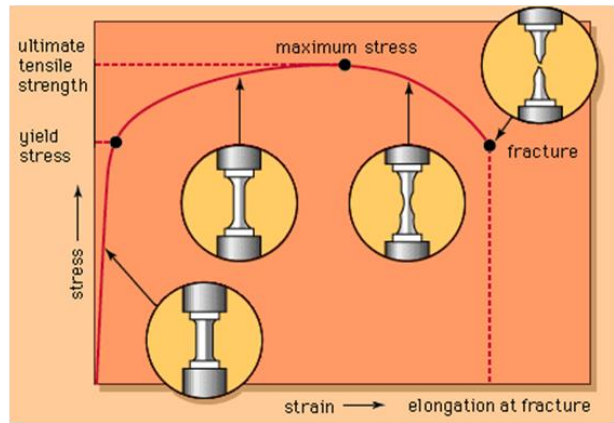

A typical graph for a mild steel sample obtained by plotting Load (Stress) against Elongation (Strain).

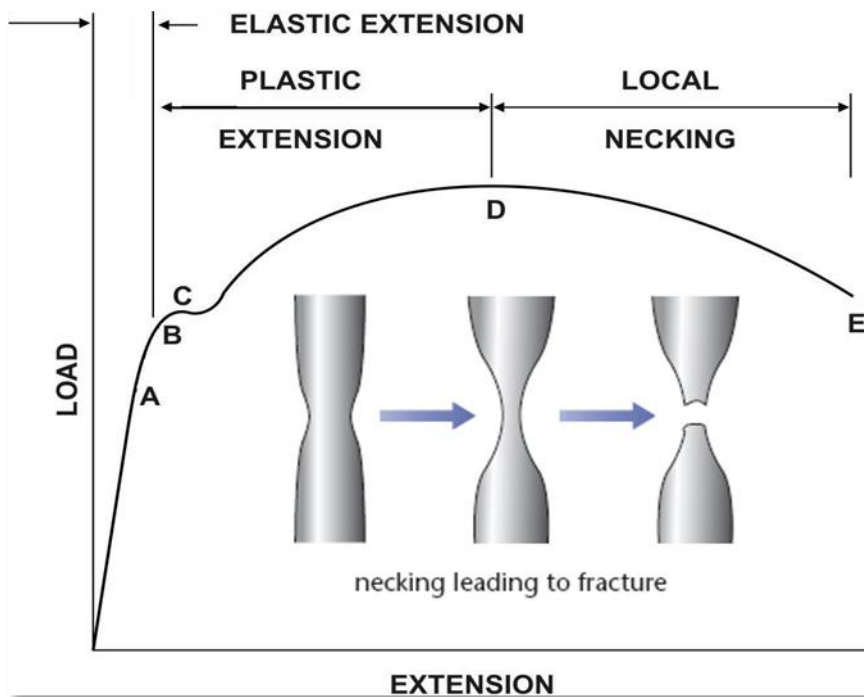

Five definite points can be seen as the line of the graph is produced.

- A. Limit of Proportionality
- B. Elastic Limit
- C. Yield Point
- D. Tensile Strength
- E. Ultimate Breaking Stress

Other measurements may be determined from the test

Percentage Elongation - This is the increase in length divided by the original length expressed as a percentage and this is a measure of the materials ductility, i.e.

$$\% \text{ Elongation} = \frac{\text{Increase in Length}}{\text{Original Length}} \times 100$$

Percentage Reduction in Area - This is the reduction in area at the point of maximum 'necking' divided by the original cross sectional area expressed as a percentage, i.e.

$$\% \text{ Reduction in Area} = \frac{\text{Decrease in CSA}}{\text{Original CSA}} \times 100$$

Tensile Test Results

The result is a Load/Extension diagram. This is also a diagram of Stress/Strain as the load results in stress and the extension is a measure of the strain.

Five definite points can be seen as the line of the graph is produced.

- A. Limit of Proportionality
- B. Elastic Limit
- C. Yield Point
- D. Tensile Strength
- E. Ultimate Breaking Stress

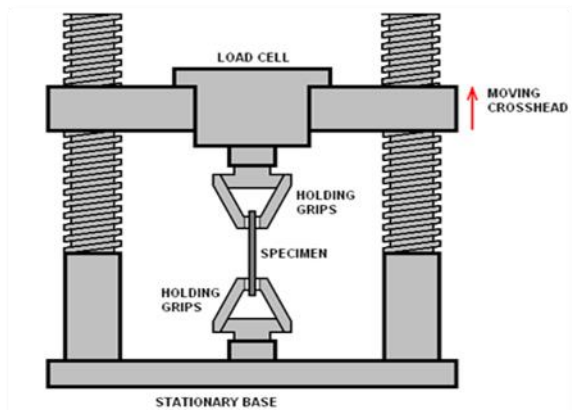

Tensile Test Definitions

Limit of Proportionality

Initially as the force is applied the stress and strain are proportional until point A is reached. This is the point at which the graph is no longer a straight line. This point is known as the Limit of Proportionality.

The Elastic Limit

This is the point up to which the material remains elastic. Within the elastic limit the test piece will return to its original dimensions if the load is removed. (With mild steel this point practically corresponds with the Limit of Proportionality. This is not generally true of other materials or for materials that have been overstrained). When this point has been exceeded the extension is permanent and is referred to as Plastic Deformation.

Yield Point

Slightly above the elastic limit, the Yield Point is reached when a sudden permanent extension, B to C, occurs without any increase in load. (Sometimes there is a slight drop in the load, due to the extension, giving an upper and lower yield point).

Tensile Strength

The Tensile Strength is reached at this point. When this is passed the cross-sectional area becomes noticeably smaller and 'necking' occurs. This is the point of maximum load.

Ultimate Breaking Stress

This is the actual breaking load where an increase in stress is obtained with a reduction in load. Although the value is smaller than the tensile strength this gives a false impression of what actually occurred. From points D to E the section of the test piece considerably reduces as it 'necks' - thereby effectively increasing the stress. However, as the graph records the stress as load over the original cross-sectional area, it appears to decrease.

Notes:

Tensile Test Results

We can see from the tensile test graph opposite that there is a clear difference between a ductile material and a brittle material under the same tensile test.

The brittle test piece withstands deformation until the stress applied is at a relatively high level. It then yields, deforms and fractures.

The ductile test piece withstands deformation but yields at a lower level of stress than the brittle test piece. This is because the ductile material is not as strong as the brittle material.

The ductile material then continues to elongate, reaching its maximum tensile stress and eventually fracturing.

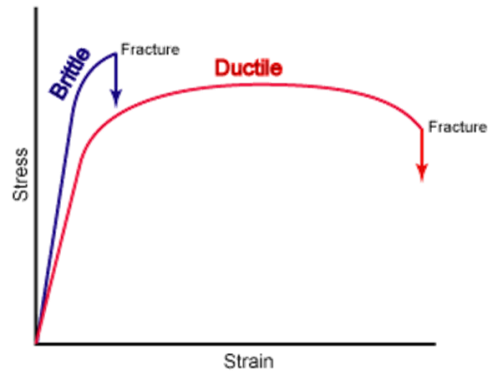

Notes:

Verification

Verification is the generic term used to describe the procedures adopted by the manufacturer or competent person to ensure that lifting equipment is of the required standard or specification, that it meets legal requirements and is safe to operate. This may include proof load testing, sample break testing, non-destructive testing, calculation, measurement and thorough examinations.



Note:

For new equipment, the verification methods used by the manufacturer will depend on the standard being worked to. Some equipment is unsuitable for proof load testing due to the nature of the materials used and some items are assembled from components verified to their own standards, therefore no further tests are required. Once in service, the verification methods used will be those deemed necessary by the competent person in reaching his conclusions about fitness for purpose.

All lifting equipment must be verified:

- (a) To ensure it is safe before first use, and
- (b) Periodically once it is in service to ensure it remains safe to use

Extract from LOLER

Every employer shall ensure that before lifting equipment is put into service for the first time by him it is thoroughly examined for any defect unless either –

- (a) The lifting equipment has not been used before; and
- (b) In the case of lifting equipment for which an EC declaration of conformity could or (in the case of a declaration under the Lifts Regulations 1997) should have been drawn up, the employer has received such declaration made not more than 12 months before the lifting equipment is put into service

Or, if obtained from the undertaking of another person, it is accompanied by physical evidence.

For in-service equipment, LOLER places the duty for deciding if, and what, tests are necessary on the 'competent person' making a thorough examination.

It requires the details of any tests made to be included on the examination report.

Note the words: 'any test'.

The report needs to include any test, not just a proof load test. This could include functional, light load, non-destructive tests etc. LOLER does not use the word 'test' but instead refers to a 'thorough examination'.

The purpose of the examination is to determine if the item being examined is safe to use or otherwise. The majority of general lifting equipment will require as a minimum a basic functional test with no load to ensure the equipment functions correctly.

Competent Person

The term 'Competent Person' has long been used in legislation.

Current legislation uses it for a variety of duties to describe a person with the necessary knowledge, experience, training, skill and ability to perform the specific duty to which the requirement refers.

There can therefore be several 'Competent Persons', each with their own duties and responsibilities, i.e. competent for the purpose.

LEEA Definition of a Competent Person

The term, 'Competent Person' has never been fully defined in law but, for the purpose of thoroughly examining lifting equipment, the LEEA definition of a Competent Person is a person having such practical and theoretical knowledge and experience of the equipment which is to be thoroughly examined that will enable him/her to detect defects or weaknesses which it is the purpose of the examination to discover and assess their importance to the safety of the equipment.

The Competent Person should have the maturity to seek such specialist advice and assistance as may be required to enable him/her to make necessary judgements and be a sound judge of the extent to which he/she can accept the supporting opinions of other specialists. He/she must be able to certify with confidence whether it is free from patent defect and suitable in every way for the duty for which the equipment is required.

It is the view of LEEA that competency can be a corporate responsibility.

LOLER ACoP Minimum Requirements for a Competent Person

You should ensure that the person carrying out a thorough examination has such appropriate practical and theoretical knowledge and experience of the lifting equipment to be thoroughly examined as will enable them to detect defects or weaknesses and to assess their importance in relation to the safety and continued use of the lifting equipment.

Thorough examination is required at several points during the life of lifting equipment:

- On initial use or following installation
- Periodically during its life to ensure it remains fit for use
- Following certain exceptional circumstances, e.g. if it is damaged

The Thorough Examination

The thorough examination can be broken down into 3 distinct areas:

1. Preparing for the thorough examination
2. Conducting the thorough examination
3. Actions following the thorough examination

During the remainder of this module, we will break down each area and look at them in depth.

Preparing for a Thorough Examination

Adequate Light

Eyesight

Clean Work Area

Clean Equipment

Systematic Approach



Reference Documents

Suspension Point

Assistant

Tools

Test Equipment

A judgement has to be made as to whether the item is fit to continue for a period of service.

In simple terms, will the equipment be safe to operate until the next examination is due, given its current condition and the prevailing service conditions?

Scope of the Examination

- What items are required to be examined? (See reference documents)
- Does the owner require the items to be marked or colour coded after examination?
- Is all the equipment to be examined available?
- If you are to use test weights, are the floor areas where the test weights will pass over of adequate strength?
- Is the equipment to be examined in accordance with a written scheme of examination?
- Has the equipment been modified?
- What repairs have been carried out to the equipment?

Note: If a chain sling is to be repaired it is advised that the manufacturer's certificate is consulted and damaged components are replaced with only those that are identified in the list. The use of equivalent components from other system manufacturers may result in the original declaration of conformity becoming void. In this case LEEA recommend that following the work the details of the repair are recorded in the sling maintenance log and the equipment is thoroughly examined by a competent person and also recorded in the report of thorough examination.

Well Lit, Clean and Safe Area

- Is there sufficient lighting (natural or artificial) in the area where the examination is to take place?
- Is the area clear from contaminants that can harm the equipment under examination or the examiner themselves?
- Is the examination area safe from hazards, moving traffic, ongoing lifting operations etc.?

If you are concerned for your own safety, you will be distracted and unable to give 100% concentration to the examination task at hand.

Cleaning Materials

- Does the equipment require cleaning before the examination is carried out? (Dirty equipment can be hiding faults)
- Always ensure that the method of cleaning will not cause damage to the owner's equipment. (Follow manufacturers guidance for cleaning)



Reference Documents

- Do you have access to the manufacturers' declaration of conformity and previous examination reports?
- Do you have the correct standards for the equipment you are examining?
 - Be aware that some standards reference other standards for examination e.g. BS EN 13155 references BS EN 818-6 for the examination criteria for any chain slings that are used as part of a lifting beam
- Do you have manufacturers' technical brochures or catalogues to give specific dimensions etc.?

Suitable Suspension Point

- Will the suspension point be strong enough to withstand any load testing that you need to carry out?
- Is the suspension point at a height that enables the examiner to carry out a thorough examination? (Using all of the inspection period in an uncomfortable work position causes the examiner to become less observant and can lead to back problems over time)



Test Equipment

- Is your test equipment and test weights (if used) calibrated?
 - Certificates of calibration should be made available to the owner of the equipment
- Do you have the correct test equipment?

Assistant / Site Representative

- Is there an assistant / site representative available for locating equipment to be examined?
- Does the assistant / site representative know of the quarantine procedures for defective equipment?
- Do you need items of equipment to be dismantled to enable a thorough examination to take place?

Tools

Note: this list is not only covers basic requirements. Other specific tools may be required.

Do you have:

- A basic tool kit that will enable you to remove covers, split pins, nuts, bolts and circlips during the thorough examination of the equipment?
- A camera to highlight defects?
- A calculator to calculate wear, elongation etc.
- Calibrated fine measuring tools?
- The recommended size marking stamps or other methods of marking the equipment?

Conducting the Examination

The examination shall be carried out by a competent person in accordance with the schedule of requirements.

The examination must be carried out in a logical sequence to minimise the chances of missing a part of the equipment under examination.

The identification number and SWL shall be checked and cross referenced with the manufacturer's Declaration of Conformity of the accessory. Where markings have become illegible, these shall be re-stamped or marked.

Where appropriate, the standard procedures of examination, checking of hooks, chain sizes, pitch and diameter of wires etc. shall be those recommended by the manufacturer. Further criteria may also be given in Standards.

Parts shall be exposed and examined sufficiently to enable a proper conclusion as to their condition to be reached and reported on and where necessary parts must be dismantled and cleaned to achieve this.

The assembly of parts and anchorages must be checked for correctness and proper operation and all locking and securing devices must be checked as being sound and in place.

The procedures given in conducting the examination shall be carried out in full, with a view to establishing the condition and suitability of the article for test before any testing is commenced.

Notes:

Testing as Part of the Thorough Examination

Extract from LOLER ACoP

The competent person should decide whether or not a load test is necessary, and the nature of the test, as part of the thorough examination.

The design of certain lifting equipment is such that damage may be caused by conventional overload tests. The competent person carrying out the thorough examination or testing should take account of the instructions and other relevant information, e.g. regularity of such testing, provided by the manufacturer.

Other testing may be carried out as part of the thorough examination where the competent person considers they are required to properly assess the safety of the equipment, e.g. non-destructive tests.

Test Machines and force Measuring Equipment

Test machines and load cells must be calibrated and verified in accordance with BS EN ISO 7500 – 1 at intervals not exceeding 12 months.

Requires that the accuracy of the applied load/force must be within that required by the standard being worked to and, in all cases, within $\pm 2\%$ of the nominal load/force.

Various classes or grades of machines:

- Class 0.5
- Class 1.0
- Class 2.0

The information will be on the certificate of calibration and verification.

In some cases two grades may be shown e.g. grade 1.0 for one range of readings, grade 2.0 for a further range of readings.

Notes:

Types of Tests

Liquid/Dye Penetrant Testing (PT)

Penetrant testing locates surface-breaking discontinuities by covering the item with a penetrating liquid drawn into the discontinuity by capillary action. After removal of excess penetrant the indication is made visible by application of a developer (colour contrast or fluorescent).

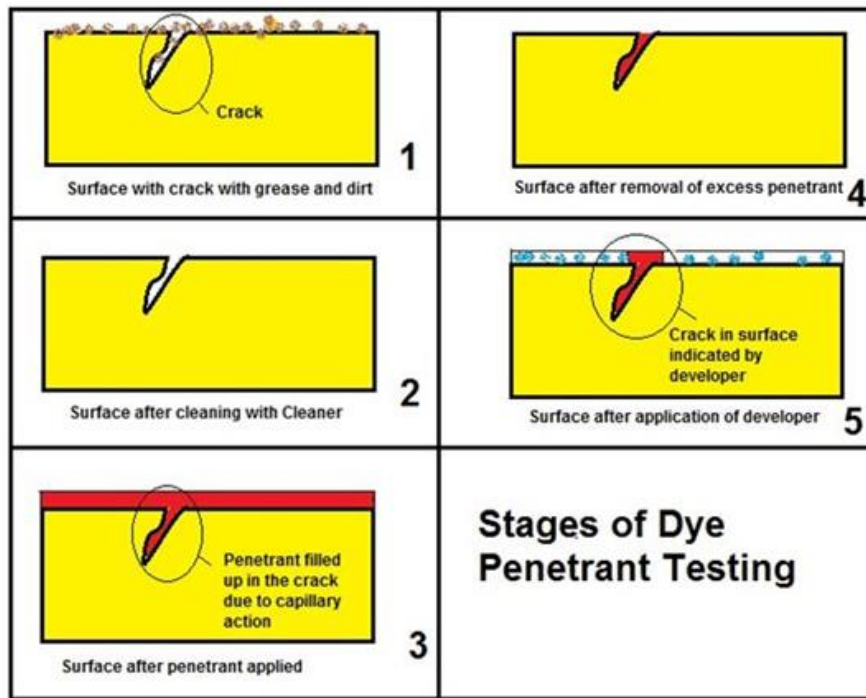

Magnetic Particle Inspection

Magnetic particle inspection (MPI) is used to locate surface and slightly sub-surface discontinuities in ferromagnetic materials by introducing a magnetic flux into the material.

- White background lacquer is applied to the area to be inspected
- Items are magnetized and then sprayed with a solution of suspended iron filings
- Cracks or imperfections near the surface will distort the magnetic field
- Will attract the iron filings revealing the flaw by an accumulation of particles along the line of the crack
- Sub-surface defects by an accumulation in the area over the fault

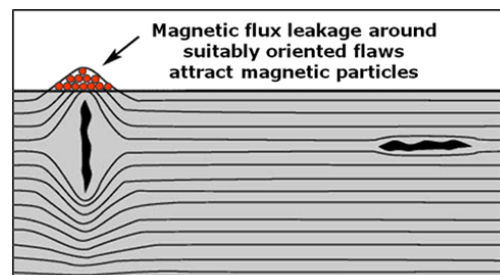

Eddy Current Inspection

Eddy current inspection is based on inducing electrical currents in the material being inspected and observing the interaction between those currents and the material. Eddy currents generated by coils in the test probe are monitored by measuring the coils electrical impedance. As it is an electromagnetic induction process, direct electrical contact with the sample is not required; but the material must be an electrical conductor.

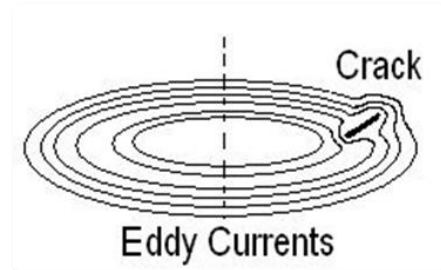
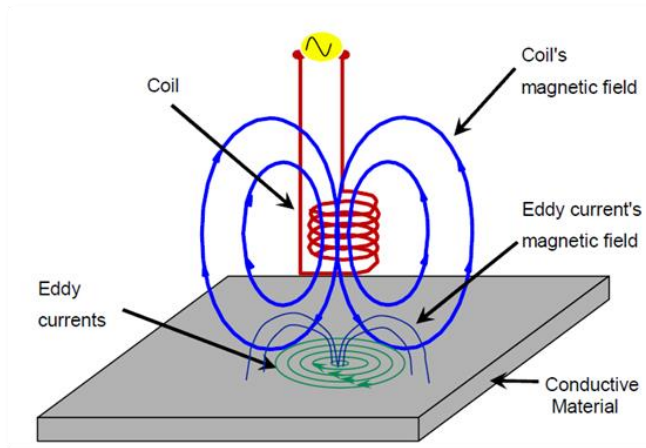

Ultrasonic Testing

Ultrasonic testing (UT) measures the time for high frequency (0.5-50MHz) pulses of ultrasound to travel through the inspection material. If a discontinuity is present the ultrasound returns to the probe in a period other than would be expected of a fault free specimen.

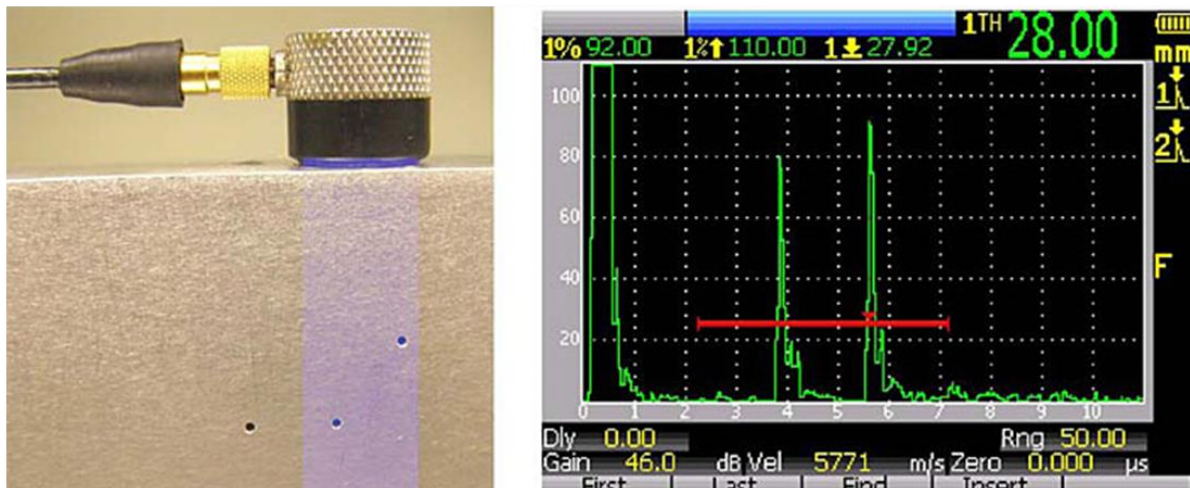

Radiography

Radiography (RT) monitors the varying transmission of ionising radiation through a material with the aid of photographic film or fluorescent screens to detect changes in density and thickness. It will locate internal and surface-breaking defects. As shown on the weld defect below, this would have been impossible to detect with a surface only method of NDT.

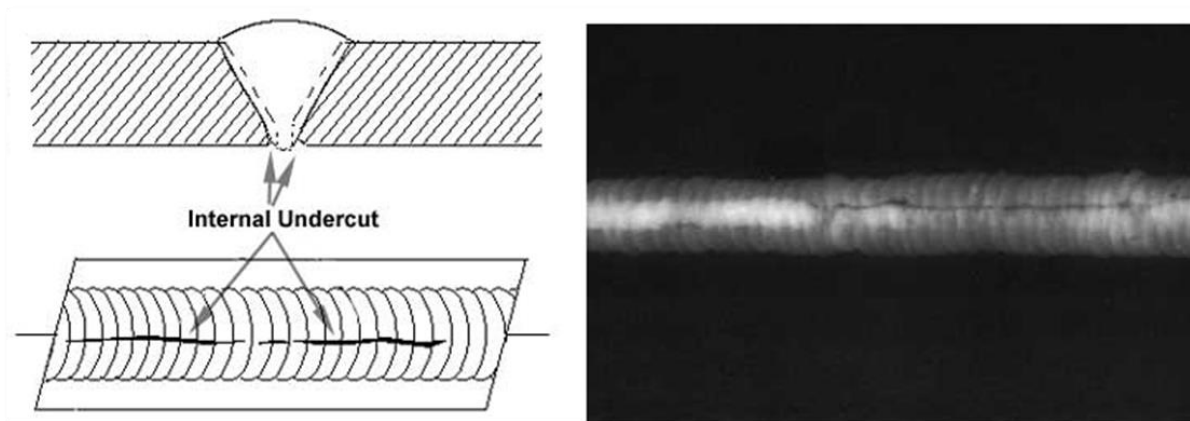

Proof Loads and Test Forces

49

Where proof testing is appropriate, the load or force applied should be that given in the relevant standard or specification to which it was manufactured. In the absence of such information the following International Labour Organisation table gives accepted proof load/force factors.

ILO Table for of proof load/force factors					
SWL (tonnes)	Lifting Appliances	Single Sheave Pulley Blocks	Multi-sheave Pulley Blocks	Lifting Frames, Beams and Spreaders	Other Lifting Gear
0 – 10	SWL x 1.25	SWL x 4	SWL x 2	SWL x 2	SWL x 2
11 – 20	SWL x 1.25	SWL x 4	SWL x 2	SWL x 1.04 + 9.6	SWL x 2
21 – 25	SWL + 5	SWL x 4	SWL x 2	SWL x 1.04 + 9.6	SWL x 2
26 – 50	SWL + 5	SWL x 4	SWL x 0.933 + 27	SWL x 1.04 + 9.6	SWL x 1.22 + 20
51 – 160	SWL x 1.1	SWL x 4	SWL x 0.933 + 27	SWL x 1.04 + 9.6	SWL x 1.22 + 20
161 and over	SWL x 1.1	SWL x 4	SWL x 1.1	SWL x 1.1	SWL x 1.22 + 20

Actions Following and Examination

Following an examination the tester and examiner must prepare a report regardless of whether or not the item has passed the examination.

Extract from LOLER ACoP

Where the competent person identifies defects which must be made good within a specified timescale, they should submit the report promptly to allow the employer to take the necessary action within the required period.

In normal circumstances the competent person should complete the report and forward it within 28 days of the thorough examination.

Extract from LOLER Guidance

The competent person should make a report of the state of the equipment at the time of the thorough examination. Defects should be notified even if there is no intention to use the equipment again (such as when it is immediately scrapped) or not immediately to do so (e.g. equipment taken out of use until repairs can be carried out). The duty applies even where repairs are carried out immediately. In all cases the competent person should make a report on the condition of the equipment which necessitates the repairs.

Competent persons' reports are a vital diagnostic aid in the safe management of lifting equipment. If defects are habitually not detected or rectified until the competent person's thorough examination this indicates inadequacies in management systems. Where a competent person repairs a defect on the spot, or immediately prior to thorough examination, it should be included in their report. Failing to report such a defect is disguising a potentially dangerous situation.

For in-service equipment, if the examination reveals one or more defects which present an immediate or imminent risk of serious or personal injury, a copy of the report must be sent to the relevant enforcing authority.

In this regulation "relevant enforcing authority" means –

- (a) Where the defective equipment has been hired or leased by the employer, the Executive; and
- (b) Otherwise, the enforcing authority for the premises in which the defective equipment was thoroughly examined

This is a duty placed on the person making the examination.

Although your company may have a procedure for doing this, it is your legal responsibility to ensure it has been done.

Components for Slings

Component Design

Components covered by BS EN 1677 are normally supplied to be used as a part of a sling, but they are commonly found in use for other applications.

It is important to ensure that the design and capability of any such component has been checked to ensure that it is suitable for the intended use; this information will be available from the component manufacturer.

BS EN 1677 parts 1 to 6 state that Manufacturer's Instructions for Use should be supplied with all components, stating:

- The intended use
- The limits of use
- Instructions for handling, storing, assembly, use and maintenance

Applicable Standards and References

The following European standards apply to the general requirements for components in use with lifting slings made from:

- Chain
- Steel wire rope
- Textiles

BS EN 1677-1: Components for slings - Safety - Part 1: Forged steel components - Grade 8

BS EN 1677-2: Components for slings - Safety - Part 2: Forged steel lifting hooks with latch - Grade 8

BS EN 1677-3: Components for slings - Safety - Part 3: Forged steel self-locking hooks - Grade 8

BS EN 1677-4: Components for slings - Safety - Part 4: Links - Grade 8

BS EN 1677-5: Components for slings - Safety - Part 5: Forged steel lifting hooks with latch - Grade 4

BS EN 1677-6: Components for slings - Safety - Part 6: Links - Grade 4

Notes:

Definitions

Working Load Limit (WLL)

Maximum mass that a component is authorized to sustain under ideal lifting conditions.

Manufacturing Proof Force (MPF)

Force applied to the component during the manufacturing proof test.

Breaking Force (BF)

Maximum force reached during the static tensile test of the component that the component fails to retain the load.

Traceability Code

Series of letters and/or numbers, marked on a component which enables its manufacturing history including the identity of the cast of steel to be traced.

Sling

Assembly consisting of chain, textile or steel wire rope joined to upper and lower terminals suitable for attaching loads to the hook of a crane or other lifting appliance.



Master Link

Link forming the upper terminal of a sling by means of which the sling is connected to the crane or other lifting appliance.



Intermediate Master Link

Link used to connect one or two legs of a sling to a master link.

Master Link Assembly

Assembly consisting of a master link and two intermediate links.

Lower Terminal

Link, hook or other device fitted at the end of a leg of a sling, remote from the master link or upper terminal.



Self-Locking Hook

Hook containing a locking mechanism, capable of being activated by the action of the load which, once correctly closed and locked, can only be opened in the unloaded condition by de-activation of the locking mechanism.



Forging

Most components are drop forged. The initial bending of a bar is made by hand forging and welding, with the finishing to size being by drop forging.

Common Forging Defects

Although the forging process is basic, it calls for great skill from the operator if forging faults are to be avoided. The types of defect that occur during manufacture are therefore much the same, irrespective of the component being produced.

Gall marks - an over lapping of the material during working which is closed into the material below welding temperature. Under load they will open up and act as stress raisers, eventually becoming cracks.

Laminated material - will act as a stress raiser which will eventually crack. This is often difficult to detect as its appearance will differ with its position and the methods of working applied to the material. Often it will look like a discoloured line running along or across the item.

Cracks - can occur in several ways in addition to those mentioned above, the most common occurring during heat treatment when over stressed material is quenched too quickly. They can also occur due to chemical contamination, e.g. with acids or acidic gasses.

Weld faults - must be considered when looking at welded rings and links. Weld cracks can develop during manufacture or in service. Other manufacturing weld faults are lack of penetration, appearing as a lap between the weld and the parent material, undercutting, gas blow holes and slag inclusions. These may be difficult to identify in links which have been welded before the final forging process.

Gouges and incomplete section - can occur from careless handling during forging. A gouge will appear as a groove or score line in the material. If insufficient material is placed in the dies the full shape and section of the component will not be formed.

Burnt material - occurs if the forging temperature is exceeded. The material will take on a glazed or crystalline appearance and may develop a high number of hairline cracks.

Multiple and offset stamping - occurs if the item is moved during the drop forging process. Drop forging is a highly skilled art calling for the billet to be held firmly and steadily in position. If the billet from which the forging is to be made is not held correctly in the dies, or if it is moved between strikes of the hammer, misshapen components will result. There are various forms that this type of defect can take, although they are obvious during an examination.



Rings

Rings were once the most common master (head) fitting for slings. They were also used for other purposes from time to time, such as fitting through the eye of an eyebolt to remove the need for the use of a shackle. They are rarely used in the manufacture of modern lifting slings.

An important reason for their decline is safety. A ring can freely turn in use and, if the ring is welded, the position of the weld cannot be guaranteed. The weld could therefore be placed in a position of high stress. Again this problem is generally overcome by the use of a link. Due to the foregoing problem, it is considered that the use of welded rings in new equipment does not meet with the essential safety requirements laid down in the European Machinery Directive (Supply of Machinery (Safety) Regulations in the UK).

A large amount of older equipment remains in service which is fitted with rings, however, it should be noted that BS EN 1677 does not specify requirements for rings.



Links



In the case of master links intended for chain sling assembly, the link section may be flattened to increase its depth and/or permit narrow jawed coupling components to be fitted to them. Often only a small area on one of the sides of a link is flattened, or further flattened, to allow narrow jawed coupling components to be fitted.

In the case of grade 8 links conforming to BS EN 1677-4, they will have been proof load tested at the time of manufacture, or verified by other means permitted by the standard. The proof load applied is a minimum of 2.5 x WLL and up to 70% of the radii will usually be supported during this test to prevent the link from collapsing. No alterations, cutting and welding should be carried out to these grades of material and damaged links cannot be repaired.

Notes:

Egg Links

Egg links are so called because they are of an oval shape in profile, resembling that of an egg or pear, with a large diameter at one end and a smaller diameter the other. They were once common in use, either as the terminal fittings to collar chain slings, where one end can reeve through the other for use in choke hitch, or fitted to collar eyebolts to enable hooks to be attached without the need for a shackle.



They may still be available in grades 8 or 10 with an integral clevis by which the chain is fitted so that their position is guaranteed. In all other cases their continued use should be questioned on the grounds of safety. Like a ring, they can easily turn in service. If they invert so that the smaller end seats on a hook, the hook will be too wide causing the link to deform and/or crack across the weld. It is therefore considered that egg links do not meet with the essential safety requirements of the Machinery Directive (Supply of Machinery (Safety) Regulations in the UK).

Hooks

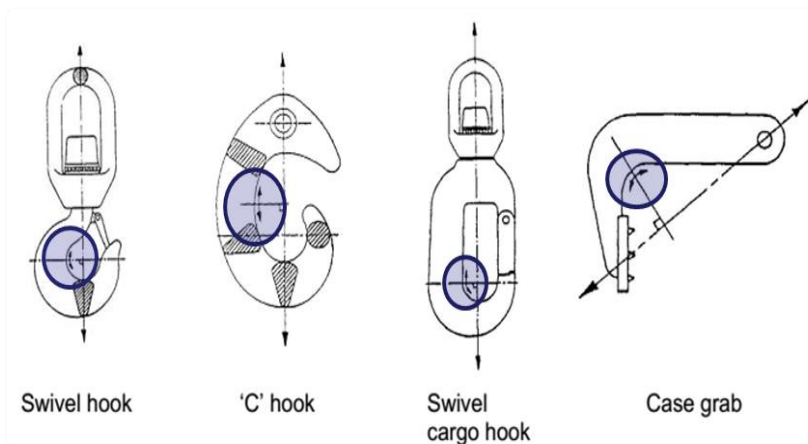

A few years ago, nearly all of the hooks seen on lifting equipment were of trapezoidal section. The British Standard BS 2903, covering these was withdrawn some years ago and it is left to manufacturers to adopt their own designs within the parameters of BS EN 1677-2, -3, and -5.

It is now rare to find hooks of trapezoidal section in use with lifting gear, except in special circumstances or when dealing with older in-service equipment. Even so the general principles of hook design are well established and are followed by the manufacturers.

The maximum tensile stress occurs at the extreme layers of the intrados, at right angles to the line of pull, and at the greatest distance from it.

Notes:

Hook Design

Hooks are designed so that, should they be over loaded, the hook will open slowly and transfer the point of maximum stress onto a slightly larger cross section. In this way the hook actually becomes stronger when it opens, so slowing the failure and giving the operative a clear visible warning.



'C' Hooks (designed to be used without safety latches)

Safety Requirements (Hook Latches)

The latch shall engage in the point of the hook to form a complete closure of mating surfaces. With the hook in any orientation the spring shall ensure that the latch is held positively in the closed position. Latches operated solely by gravity shall not be used.

The spring shall be constructed from corrosion protected material and shall be able to withstand at least 10,000 complete openings of the latch without fracture.



Chain Shorteners

Chain shorteners may be used as an optional component, built into a chain sling that facilitates the shortening of the chain legs to accommodate varying sling requirements. The shorteners are commonly supplied as clutches or grab hooks.

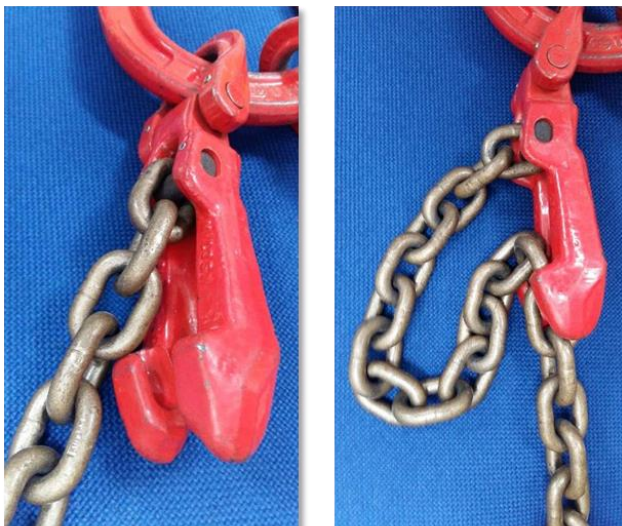

Clutch

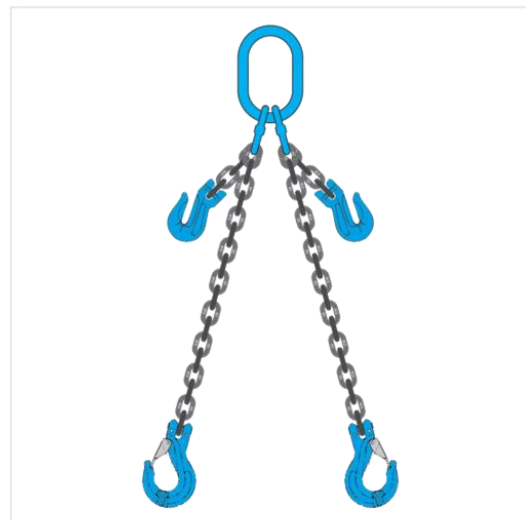

Grab Hooks

Common In-Service Faults

In addition to the common forging faults, mentioned above, the examiner must also look for the following in service defects when making an examination.

Wear – the maximum permissible wear for an item with a curved or circular cross section is an 8% reduction of the nominal diameter or a 10% loss of material for other sections. However this assumes that the wear is even. Wear is obvious to see and the tester and examiner must use his judgement cautiously. If wear is not the only consideration, he will often find he is removing items from service long before the limit is reached.

Burring or bruising and material movement – as the material begins to wear, or is subjected to shock loading and/or vibration, it may move or flow. If this is severe, cracks will form appearing in a similar manner to a chisel head that has been struck several times and burred over. No material movement should be permitted on items being returned to service.

Distortion and Deformation – sideways twisting, bending, closing in, opening up, elongation and similar distortion and deformation are all grounds for immediate rejection.

Nicks, cuts and gouges – these defects, caused by careless handling, all act as stress raisers and will eventually lead to cracking and thus are grounds for immediate rejection.

Corrosion and chemical attack – any corrosion should be treated with caution and should be cleaned off prior to the examination. Should there be any resulting pitting this will act as a stress raiser and lead to cracking. The alloy steels used in lifting gear manufacture are subject to hydrogen embrittlement and associated hairline cracking if they are subject to exposure to acids or acidic fumes. Great care is therefore needed during the examination and such items must be removed from service.

Markings

Each component shall be legibly and indelibly marked in a place where the marking will not be removed by use and in a manner that will not impair the mechanical properties. The marking shall include the following information:

- Code number that identifies the WLL (refer to BS EN 1677 series of standards)
- The grade number
- The manufacturer's mark, name or symbol
- The traceability code



Additional Markings for Load Bearing Pins

Each load bearing pin of 13mm and above shall also be legibly and indelibly marked with the relevant grade number and manufacturer's symbol.

NOTE: Each individual component manufactured to BS EN 1677 does not require CE marking due to the fact that they are designed to be used as part of a sling and it is the completed sling which when compliant with the relevant standard that requires the CE Marking.

Manufacturer's Documentation

Sling Components (Manufacturers Certificate)

The certificate shall include at least the following information:

- Business name and address of the manufacturer or authorised representative, including the date of issue of the certificate and authentication
- The number and relevant part of the European standard, e.g. EN 1677-1
- Code number
- The quantity and description of the component
- The grade number
- The working load limit in tonnes
- The manufacturing proof force in accordance with the relevant part of the European standard in kilonewtons
- Confirmation that the minimum proof force was met or exceeded
- An identification of the quality system to EN ISO 9002 when in place and operating

Manufacturers' Instructions for Use

The instructions for sling components should contain the following general information:

- The intended use
- The limits of use
- Instructions for handling, storing, assembly, use and maintenance

Additionally for Self-Locking Hooks:

- How to close the latch manually by the operator
- How to use the locking mechanism

Chain and Chain Slings

Chain is the most basic of lifting media, and although it is far heavier than rope it has a far longer life and is far more robust.

It can better withstand rough usage, is less likely to damage, is almost perfectly flexible and can be stored for long periods without serious deterioration.

In use it tends to show evidence of damage better than wire rope or textiles, consequently examination is more reliable. Therefore it remains the principle component of much lifting equipment. In this unit we will consider the various grades of chain covered by the BS EN 818 series of standards.

The following European standards are applicable to chain and chain slings:

- BS EN 818- 1: General conditions of acceptance
- BS EN 818 – 2 Medium tolerance chain for chain slings - Grade 8
- BS EN 818 - 3: Medium tolerance chain for chain slings - Grade 4
- BS EN 818 - 4: Chain slings - Grade 8
- BS EN 818 - 5: Chain slings - Grade 4
- BS EN 818 - 6: Chain slings Instructions for use and maintenance
- LEEA Code of Practice for the Safe Use of Lifting Equipment - Section 14

Over the years since the publication of the first chain standards, the grading system has developed in what may appear a somewhat confusing manner. A brief explanation is as follows:

When chain was manufactured to imperial dimensions there was a formula which related the size of the chain in inches, the grade and the minimum breaking load. This gave grade numbers such as 40, 60, 80. The higher the grade, the stronger the chain, size for size.

When chain started to be made to metric dimensions, the formula no longer applied but to identify the metric equivalents the grade marks 4, 6 and 8 were used by British Standards. However in other parts of the world the letter grades of M, S and T were used.

In the new BS EN 818 series of standards, the number grade marks are used for sling chain whilst the letter grade marks are used for hoist chain. A limited amount of grade 4 is still used for particular applications. Grade 6 is now rarely used. Grade 8 is now the most popular although higher grades, as yet not standardised, are now available.

Grade of Short Link Chain for Chain Slings

Standard	Material	Mean stress at minimum breaking force N/mm ²	Minimum factor of safety
BS 1663: 1950 Higher tensile steel chain Grade 40	carbon steel	400	5 : 1
BS 3113: 1959 Alloy steel chain Grade 60	alloy steel	600	5 : 1
BS 4942: Part 2: 1981 (ISO 1835: 1980) Short link chain Grade M(4) non-calibrated	carbon steel	400	4 : 1
BS 4942: Part 4: 1981 (ISO 3075: 1980) Short link chain Grade S(6) non-calibrated	alloy steel	630	4 : 1
BS 4942: Part 5: 1981 (ISO 3076: 1980) Short link chain Grade T(8) non-calibrated	alloy steel	800	4 : 1
BS EN 818-1: 1997 Short link chain for lifting purposes – Safety – General conditions of acceptance			
BS EN 818-2: 1997 Medium tolerance chain for chain slings – Grade 8	alloy steel	800	4 : 1
BS EN 818-3: 1999 Medium tolerance chain for chain slings – Grade 4	carbon steel	400	4 : 1

61

Short Link Chain

Only short link chain allowed for lifting purposes.

Fine tolerance for use in lifting machines, medium tolerance used generally in the manufacture of lifting slings.

Medium Tolerance

- BS EN 818-2 (grade 8)
- BS EN 818-3 (grade 4)

Fine Tolerance

- BS EN 818-7 (grade 8 machine chain)

Recognising Different Chain Grades

Fine tolerance chain may be recognised in two ways. The calibrating process has the effect of removing all of the residual scale from the heat treatment process and many of the finish treatments include corrosion resistant finishes. As a result it has a bright finish and of course there is also the grade mark. Fine tolerance chains to BS EN 818 use the letters 'T', 'DAT' and 'DT' to indicate the type of treatment given to the chain and its intended application.

Should a sling be found to use chain of these grades, it should be removed from service immediately. However, there is a slight problem here, which may apply to some older chain slings that can still be found in use.

Slings made in the UK between 1981 and 1997 may show the letter 'T' or as a grade mark. Students should therefore make themselves familiar in the recognition of fine tolerance and medium tolerance chains by looking at as many examples as possible and referring to the chain manufacturer if in doubt.

Fine tolerance chain is chain which has been manufactured to precise dimensions for use as load chain in lifting appliances - it is outside of the scope of this course, however it is important that we know a little about it.

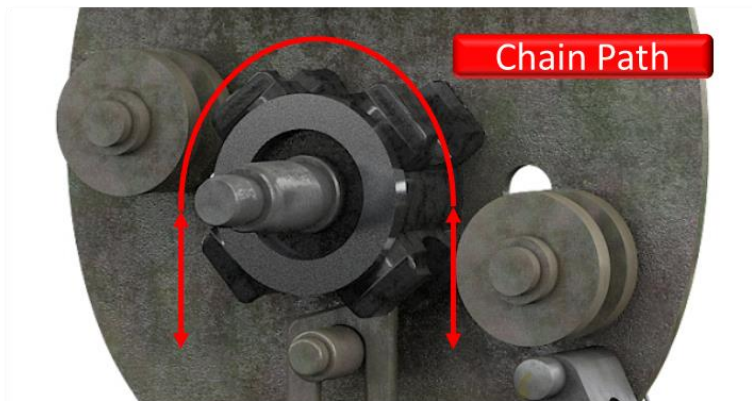
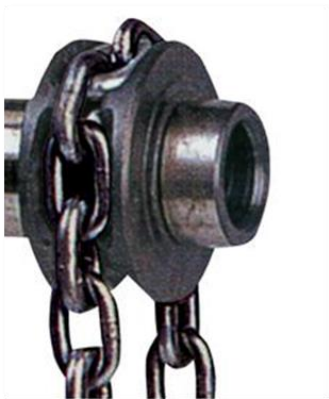

Typical Hand Chain Block Load Wheel

The pitch of the chain is important as it has to mate with other, moving, components. It is less ductile than the chain used for chain slings and has a harder skin to resist wear. As it is unsuitable for use as sling chain, we must be able to identify it in case we come across slings that incorrectly have been made using it.

Notes:

Fine and Medium Tolerance Chain

Medium tolerance chain, intended for sling manufacture, needs to be more ductile to withstand shock loading, however, in use it is not subject to wear and can therefore have a softer skin. As it does not mate with other, moving, parts it does not need to have such a precise pitch.



BS EN 818 – Basis of Grade Symbols

Grades		Mean stress at the specified minimum breaking force N/mm ²
Fine tolerance	Medium tolerance	
M	4	400
P	5	500
S	6	630
T	8	800
V	10	1000
	12	1200

Note: Chains in all of these grades may not be covered by European Standards. Grade T (Fine Tolerance) and 8 (Medium Tolerance) is currently the highest standardised grade of chain.

This grading system has also been applied to hooks, links, shackles and other accessories, indicating their strength compatibility with the appropriate grade of chain.

Notes:

Grade 10 and 12

Manufacturers have followed the spirit of the standard with regard to marking and grade 10 chain slings have become very common. Manufacturers have also developed grade 12, however both grade 10 and 12 chains are not currently covered by BS EN 818.

Long Link Chain

At one time certain types of chain sling were made from, or included, long link chain. It should be noted that the European Machinery Directive only permits the use of short link chain for lifting purposes and therefore the use of long link chain is prohibited.

Short Link Chain

The Machinery Directive states that where chain with welded link is used for lifting purposes, the chain used shall be short link chain. For the purposes of the standard BS EN 818, this means a nominal pitch to size ratio of 3:1

Nominal size: Nominal size of the round section of steel wire or bar from which the chain is made.

Material diameter: Diameter of the material in the chain link as measured.

Pitch: Internal length of a chain link as measured.

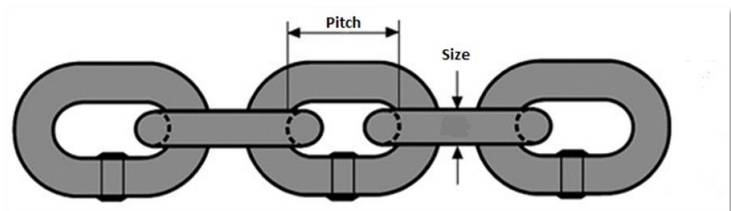

64

Heat Treatment

All the chain shall be subjected to the appropriate heat treatment specified in the Part of BS EN 818 for the particular type and grade of chain, before the application of the manufacturing proof force.

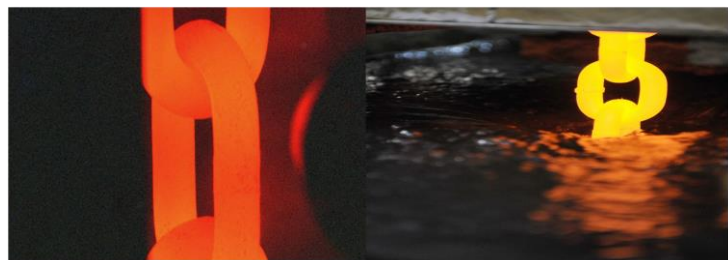

Surface Finish

The 'finished' condition for chain shall include any surface finish.

NOTE: Chains are supplied in various surface finishes e.g. natural black (i.e. furnace scaled), de-scaled, electroplated or painted.



Grade Marks

BS EN 818 series of standards call for the grade mark to appear regularly throughout the length of chain. It should appear every 20th link or at intervals of 1 metre, whichever is the lesser distance. The links must be stamped or embossed on the least stressed part of the chain, i.e. on the side of the link opposite the weld. If stamps are used to mark the chain they must have a concave surface and the indentation should be such that it does not impair the mechanical properties of the chain link.

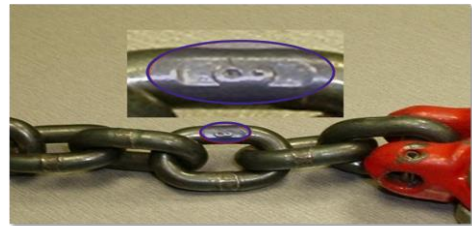

Grade 8 Medium Tolerance Chain

Manufacturer's Certificate

The manufacturer is to supply a certificate of test and examination, stating conformance with the appropriate part(s) of BS EN 818 with every supply of chain.

The certificate of test and examination shall give at least the following information:

- The name and address of the manufacturer or his authorized representative, including date of issue of the certificate and authentication
- Number and Part(s) of BS EN 818
- Quantity and description of the chain of which the test sample is representative
- Identification of the chain of which the test sample is representative
- Nominal size of chain, in millimetres
- Manufacturing proof force, in kilonewtons
- Breaking force, in kilonewtons (i.e. confirmation that the specified minimum breaking force was met or exceeded)
- Total ultimate elongation at fracture, as a percentage (i.e. confirmation that the specified Minimum total ultimate elongation has been met or exceeded)

Notes:

Types of Chain Sling



Single Leg Sling



Collar Sling



2 – Leg Sling



Adjustable 2-leg Sling



Three Leg Sling



Four Leg Sling

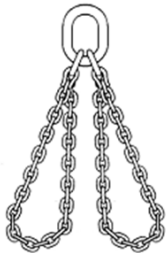

Double Basket Sling

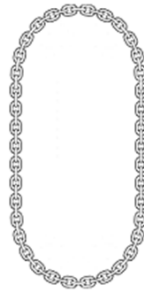

Endless Sling



Shortening Clutches

Notes:

Chain Sling Construction

Chain sling assemblies are manufactured in various material and heat-treatment combinations to produce the different grades and to suit differing service conditions. The end fittings are attached to the chain by means of:

- One or more welded joining links

Or,

- A mechanical joining device

All grades are available in welded construction but only grade 8 is available constructed with mechanical joining devices. Both methods of assembly may be applied to any grade of chain, but in practice it will be found that only grade 4 are generally produced by welding and grades 8 and 10 by mechanical assembly. In certain circumstances grade 8 welded slings may be produced, but their use is rare.

Chain Sling Construction

Modern chain slings are assembled from components which have mechanical fixings, such as spiral roll pins, to retain them. Older chain slings, and currently a few for special applications, were assembled by a blacksmith and had welded joining links.

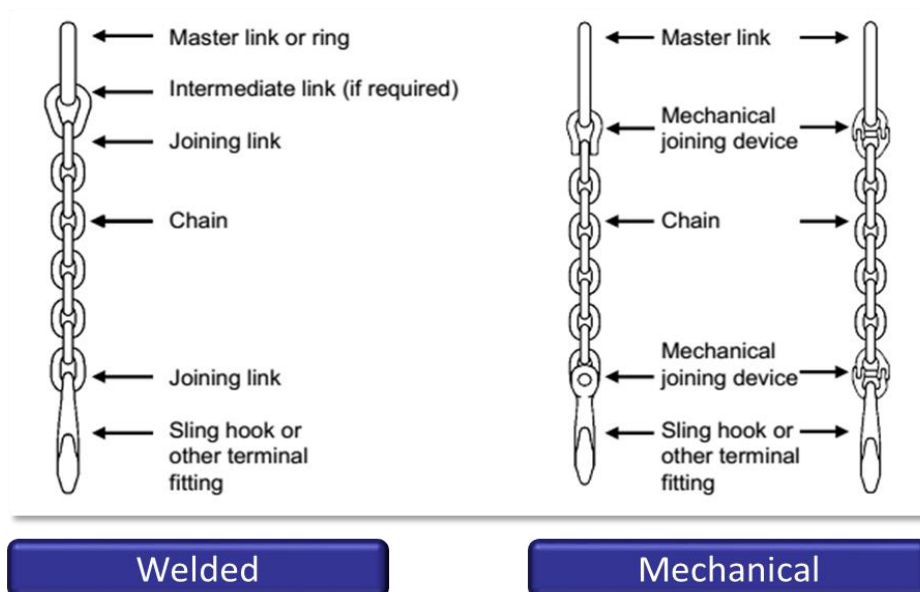

Notes:

Types of Chain Connector Pins



Chain Coupling Component

Some systems employ fittings with large eyes through which half a coupler is passed; the other half of the coupler is passed through the end link of the chain.



Couplers are available for chain to chain, chain to eye type fitting and chain to master link attachment.

The two halves of the coupler fit together and a locking/load pin passes through the centre to hold them together. The locking pin is kept in position by a central retaining collar, spring clips or circlip type fixings.

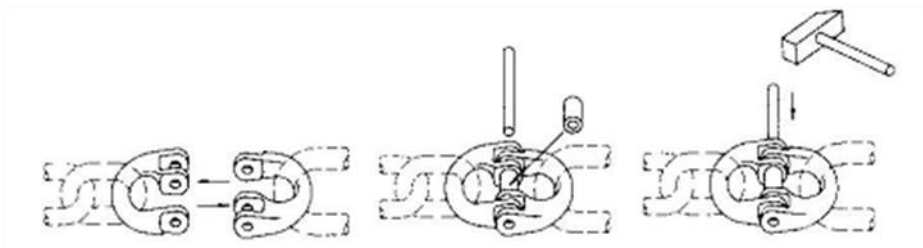

Adjustable Slings

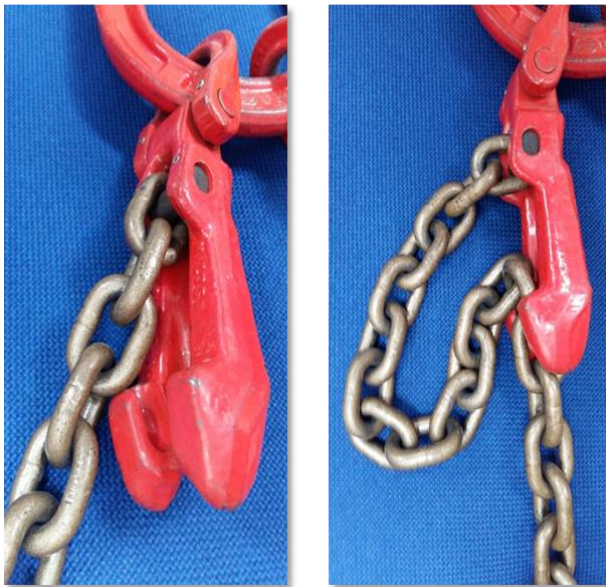

Most manufacturers can incorporate shortening devices into all sling assemblies rendering them adjustable.

Shortening clutches are the preferred devices for adjusting leg length as they maintain the correct 'in line loading' of the chain so that the rating is not affected. The use of hooks that lock onto a link of the chain, commonly known as grab hooks, is not recommended for this purpose as they involve a transverse or oblique loading on the chain. If a manufacturer provides grab hooks for shortening purposes, their recommendations on de-rating must be sought and followed.

General Precautions

Mechanically assembled chain system components are supplied by the system manufacturer in the hardened and tempered condition. As the assembly of the sling does not affect the material condition no further heat treatment is necessary, indeed it would be positively dangerous.

The components are also verified by an appropriate method and certified by the manufacturer. Assembled slings do not therefore need to be proof tested, but only thoroughly examined to ensure that they are correctly assembled and that no damage has occurred during handling and assembly. Indeed, with a system in compliance with the relevant standards, it is not possible to test a made up sling without damaging it beyond use.

Rating Chain Slings

When a multi-leg sling is used with the sling legs at an angle, the load in the individual sling legs will increase as the angle to the vertical (included angle between the legs) becomes greater. This is illustrated below:

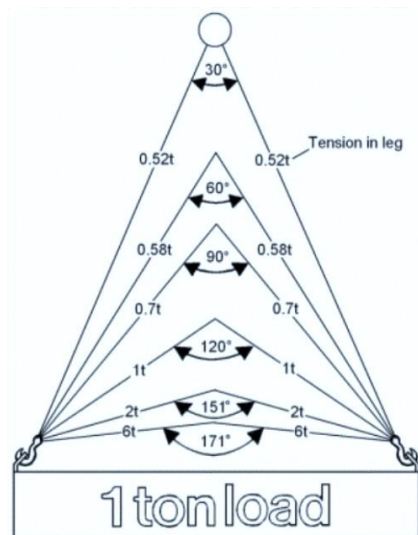

It should be noted that in the UK, the angle has traditionally been measured as the included angle α (alpha) between the legs of a two leg sling and between the diagonally opposite legs of a four leg sling.

As three leg slings do not have an 'opposite' leg it was taken for these as twice the angle to the vertical. This assumed that the legs would be symmetrically disposed in plan.

In order to emphasise that the angle of each leg to the vertical affects the share of the load it will carry and to remove the anomaly with three leg slings, Harmonised European standards measure the angle between the leg and the vertical β (beta).

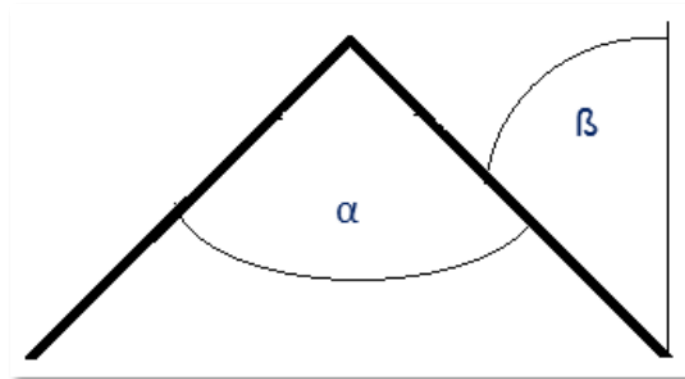

In accordance with Harmonised European standards, the rating of slings will be expressed at the range of angles of a leg to the vertical, e.g. 0-45°, however, you may find some older slings in service still marked with the included angle.

If a sling is to be used safely, allowance must be made for this angle and this is achieved by rating the sling in one of two ways. This matter is discussed in some detail in the now withdrawn standard, BS 6166, which specifies the methods and factors to be used in calculating the safe working load. The two methods of rating are often known as the 'uniform load method' and the 'trigonometric method'.

The Uniform Load Method

The uniform load method is the simpler option, having inherent safety advantages, permitting only one working load limit up to an angle of 45° to the vertical (90° included angle) and a reduced working load limit at angles between 45° and 60° to the vertical (90° and 120° included angle). This is the method which should be used for all multipurpose slings and is the only method used for them in harmonised European standards.

Notes:

Working load limits are derived from the following:

- Single leg sling = 1.0 x WLL of a single leg
- Two leg sling 0-45° (included angle 0-90°) = 1.4 x WLL of a single leg
- Two leg sling 45°-60° (included angle 90° -120°) = 1.0 x WLL of a single leg
- Three and four leg sling 0-45° (included angle 0-90°) = 2.1 x WLL of a single leg*
- Three and four leg sling 45°-60° (included angle 90° -120°) = 1.5 x WLL of a single leg

*In older British Standards covering textile slings, this factor is given as 2.0.

Recent British and European standards (where the uniform load method has been used) rate a multipurpose four leg sling at the same working load limit as a three leg sling of the same size and grade. This is on the assumption that the load might be taken by only three of the four legs.

Note:

Older British Standards do not recommend the rating of three leg slings at included angles greater than 90°. This is due to the possible hazard of a user assuming that the 'included angle' referred to the angle between the legs of the sling instead of twice the angle of a leg to the vertical. Where slings are rated and marked on the basis of the angle to the vertical this hazard does not exist.

The Trigonometric Method

The trigonometric method provides for a variation in the working load limit as the angle to the vertical (or the angle between the sling legs) varies.

This method is the one which was traditionally used in the United Kingdom, but in order to use it for multipurpose applications, the operative must be provided with tables showing the safe working loads at various angles for each size of chain, rope, etc.

It also requires the operative to be trained in judging a range of angles and has the inherent danger that if he should misjudge these, the sling may well be overloaded.

Although the uniform load method was introduced several years ago, some manufacturers continued to rate and mark multipurpose slings by the trigonometric method. Slings intended for multipurpose use marked this way will not comply with the requirements of harmonised standards and it is strongly recommended that this method should be used only for slings designed for a single purpose, as specified in withdrawn standard, BS 6166 Part 1. Working load limits are derived from the following:

- Single leg sling = 1 x WLL of a single leg
- Two leg sling = 2 x WLL of a single leg x cos β
- Three leg sling = 3 x WLL of a single leg x cos β
- Four leg sling = 4 x WLL of a single leg x cos β

Where β is equal to the angle between the sling leg and the vertical (i.e. half the included angle α).

In the case of a single purpose four leg sling designed for exclusive use in an application where the load will clearly be shared by the four legs, it is permissible to calculate the working load limit on that basis.

Re-marking of Chain Sling Rating Method

It should be clearly understood by the lifting equipment examiner that whilst equipment designed to be used under the trigonometric method may be re-rated and marked according to the uniform load method, the reverse is NOT always possible and may be dangerous.

It is therefore recommended that, to avoid confusion, all items of a given type (e.g. all chain slings) at the location should be rated and marked by the same method.

The method of expressing and marking the rating at the angle to the vertical also raises the question of how a user, with existing slings rated by the uniform load method but marked with the 'included angle', will avoid confusion when introducing new slings marked with the 'angle of inclination'. It is LEEA's recommendation that the user should consider whether a programme of re-marking is worthwhile, bearing in mind the expected life of the slings. Irrespective of whether existing slings are re-marked, there will inevitably be a period when both systems are in use. We therefore further recommend that all operatives are made aware and trained to recognise the differences.

Mode Factors

MODE FACTORS Maximum load to be lifted = mode factor x SWL marked on the sling Key: NP = non preferred, NA = not applicable								
1	2	3	4	5	6	7	8	9
Material	Single leg in line	Single leg choked	Single leg basket	Single leg back hooked	Single leg halshed	Endless in line	Endless Choked	Endless basket 0-90°
Chain	1	0.8	1.4	1	NP	NP	1	NP
Wire rope	1	0.8	1.4	1	1.6	NP	1	1.4
Webbing	1	0.8	1.4	NA	NP	1	0.8	1.4
Fibre rope	1	0.8	1.4	1	1.6	1	0.8	1.4
Roundsling	NA	NA	NA	NA	NA	1	0.8	1.4

Using less than the number of legs available

If a multi leg sling is used with less than its actual number of legs attached to the load, then obviously the safe working load of the sling must be reduced.

The amount by which it should be reduced can be calculated exactly, but it is rather complex, as a number of factors need to be taken into account including the method of rating. An easy way of ensuring that the sling is never overloaded is to reduce the safe working load from that marked on the sling according to the number of legs in use:

e.g.

- A 4 leg sling with only 2 legs in use,
Reduced SWL = $\frac{1}{2}$ x marked SWL
- A 3 leg sling with only 2 legs in use,
Reduced SWL = $\frac{2}{3}$ x marked SWL

Chain Slings used in Adverse Conditions

Low Temperature

Chain slings of grades 4 and 8 to BS EN 818 series will not be adversely affected by temperatures down to -40°C. Consult the manufacturer for applications below this temperature.

High Temperature

Grade	Working load expressed as a percentage of working load limit				
	Temperature, t , °C				
	$-40 < t \leq 200$	$200 < t \leq 300$	$300 < t \leq 400$	$400 < t \leq 475$	$t \geq 475$
4	100	100	75	50	Not permissible
8	100	90	75	Not permissible	

Using chain slings within the permitted temperature ranges does not require a permanent reduction in working load when the sling is returned to normal temperatures. If the sling reaches temperatures in excess of the maximum permitted, they should be withdrawn from service as permanent damage may have occurred.

Notes:

Acidic/Alkalic Conditions

Grade 8 chain slings should not be immersed in acid solutions or exposed to acid/alkali fumes.

Grade 4 chain slings may be used in acidic conditions but the following precautions should be taken:

- The working load should not be more than 50% of the WLL
- The sling should be thoroughly washed in clean water after use
- The sling should be inspected by a competent person each day before use

Testing of Chain Slings

- Mechanically assembled chain slings to BS EN 818-4:
 - Cannot be proof load tested without possibly damaging them
 - The test will reveal nothing that was not already known
- Welded construction chain slings:
 - It is necessary to carry out a proof test after initial manufacture
 - After any repair, to verify the joining links and any fittings used
(they may not already have been verified)

BS EN 818-4 states requirements for force/load testing. Intended as the initial, once off manufacturer's test, for welded construction grade 8 slings.

Forces are applied to each leg equivalent to 2.5 times the WLL. This test is not intended to be repeated or be applied to mechanically assembled slings.

Markings

Marking should be by means of a suitable plate or metal tab permanently attached or by stamping directly into the equipment, preferably in a non-load bearing or low stress area. Stamping into a stressed area may also be permissible provided that the mechanical properties of the component are not significantly impaired. Where applicable, the position and size of stamping should be as indicated in the relevant standard. When a plate or tag is used to convey this information, it is recommended that the identification mark should also be put directly onto the equipment so that in the event of the plate or tag becoming detached, the identity is not lost and the other information can be recovered from the related documentation.

Single leg sling:

- CE Mark
- Sling manufacturers name or symbol
- Year of manufacture
- WLL in tonnes (t)
- Identification mark
- Sling grade
- Number of legs i.e. 1, 2, 3 or 4

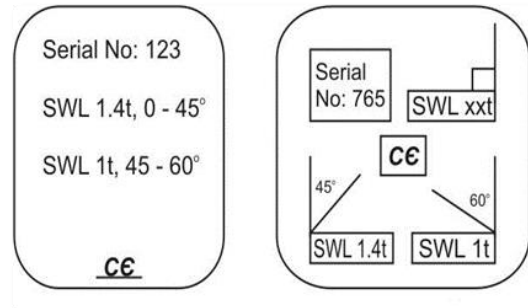

Multi-leg sling:

- CE Mark
- Sling manufacturers name or symbol
- Year of manufacture
- WLL in tonnes (t) and range of angles.
- Identification mark
- Sling grade
- Number of legs



Notes:

A large empty rectangular box for taking notes.

Documents to be supplied in Accordance with the Relevant Legislation and Standard

- EC Declaration of Conformity (guidance LEEA 030.1e)
- Manufacturers Certificate (guidance EN 818-4 / EN 818-5 clause 8)
- Manufacturer's instructions for use (guidance LEEA SI.1.3 and EN 818-6)

Note: the EC Declaration of Conformity and Manufacturers Certificate can be issued as a single document.

Manufacturers Certificate

Each assembled chain sling shall be provided with a dated certificate stating conformance with EN 818-4, giving at least the following minimum information:

- Name of the chain sling manufacturer or supplier including date of issue of the certificate and authentication.
- Number and part of the standard, e.g. EN 818-4 or EN 818-5
- The identification number or symbol of the chain sling
- A description of the chain sling, to include a list of all component parts
- The nominal size of the chain and the grade mark
- The nominal length
- The working load limit

For chain slings of welded construction the following information is required in addition to the minimum information previously stated:

- The value of the manufacturing proof force(s) applied
- The name of the person or establishment that carried out the manufacturing proof force test and final examination

For chain slings joined by mechanical devices. In the case of chain slings the following information is required in addition to the minimum information above:

- In the case of chain slings proof tested following assembly the following information:
 - The name of the person or establishment that carried out the manufacturing proof force test and final examination
 - The value of the manufacturing proof force applied
- In the case of chain slings not proof tested following assembly, the name of the competent person or establishment that carried out the visual examination

Information to be exchanged between the User and Supplier

In the case of multipurpose slings, only a general specification can be given, whereas for dedicated single purpose slings a more detailed exchange of information is necessary. In either case, the following is the minimum information which should be exchanged between the user and designer or supplier of the equipment:

Multipurpose Slings

- Details of the sling required, i.e. single leg, two leg etc, maximum load to be lifted, length of leg(s)
- Slinging conditions, if the sling is to be used in choke hitch, if the sling is to be used at 0-45° or 45°-60° as well and the maximum load to be lifted in any of these conditions.
- If shortening devices are required for sling adjustment
- The environmental conditions, including extremes of temperature and details of possible chemical attack
- The conditions of loading, including being subject to shock loads, if the nature of the load is inherently dangerous, e.g. hot metal or acids, if the load is to be transported over areas involving high risk, e.g. work areas
- Details of the largest and smallest crane hook onto which it is intended to place the upper terminal fitting
- Other technical requirements or any special requirements applicable on the site(s) where the sling is to be used

Single Purpose Slings

- All details of the load to be lifted, including the gross weight and dimensions together with the position of the centre of gravity and details of any permanently built in lifting points
- The environmental conditions, including extremes of temperature and details of possible chemical attack
- The conditions of loading, including being subject to shock loads, if the nature of the load is inherently dangerous, e.g. hot metal or acid, if the load is to be transported over areas involving high risk, e.g. work areas
- Details of the crane hook onto which the upper terminal fitting will be placed
- The headroom available
- Other technical requirements or special requirements applicable on the site(s) where the sling is to be used

The Thorough Examination

Chain slings fall under the heading of 'lifting accessories' in modern legislation and therefore should be examined by a competent person at periods not exceeding 6 months.

Nothing will be achieved by a load test of mechanically assembled slings, either during the initial or in-service examinations, as the strength is known prior to the examination. Indeed such a test to mechanically assembled slings to BS EN 818-4 will be damaging.

In discussing the examination of chain slings, whilst most of the examination procedure will be the same, we must be aware of the differences that generally apply between welded and mechanically assembled slings. It is important that the tester and examiner is able to determine how the sling he is examining is assembled and rated. Welded chain slings must be heat treated on completion of manufacture, or after repair, and subsequently be proof load tested. In this case, the report of thorough examination should show the details of the loads applied.

This is not the case with grade 8 or 10 mechanically assembled slings. A thorough visual examination must be made to ensure they are correct assembly and that all locking devices are correctly in place.

During the examination of chain slings the following should be checked:

- The chain should articulate freely
- The maximum permissible wear is 8% reduction in material diameter for the chain, components and fittings
- The maximum elongation, mainly due to seating and interlink wear, is 5% (not stretch!)
- Unless the sling is specifically designed otherwise, the legs of multi-leg slings should be of equal length so that the seat of hooks, or bearing point of other fittings, is equal. This is an important matter to check, particularly if a leg of chain has been replaced, as the pitch may vary from the original
- There should be no signs of bending, twisting or other distortion to the chain, master link or other fittings. Particular attention is necessary at the point of choke
- There should be no signs of nicks, cracks, corrosion or chemical attack
- Hooks should show no signs of opening or of distortion and, where fitted, safety catches should be undamaged and operate freely
- Marking should be clear and legible; it must give all of the necessary information for the particular grade and type of sling

Notes:

Tolerances on Leg Length

- Maximum tolerance between longest and shortest leg for slings joined by mechanical devices with nominal lengths up to and including 2m is 10mm maximum
- Maximum tolerance between longest and shortest leg for slings joined by mechanical devices with nominal lengths over 2m is 5mm/m
- Maximum tolerance between longest and shortest leg for slings assembled by welding with nominal lengths up to and including 2m is 6mm maximum
- Maximum tolerance between longest and shortest leg for slings assembled by welding with nominal lengths over 2m is 3mm/m

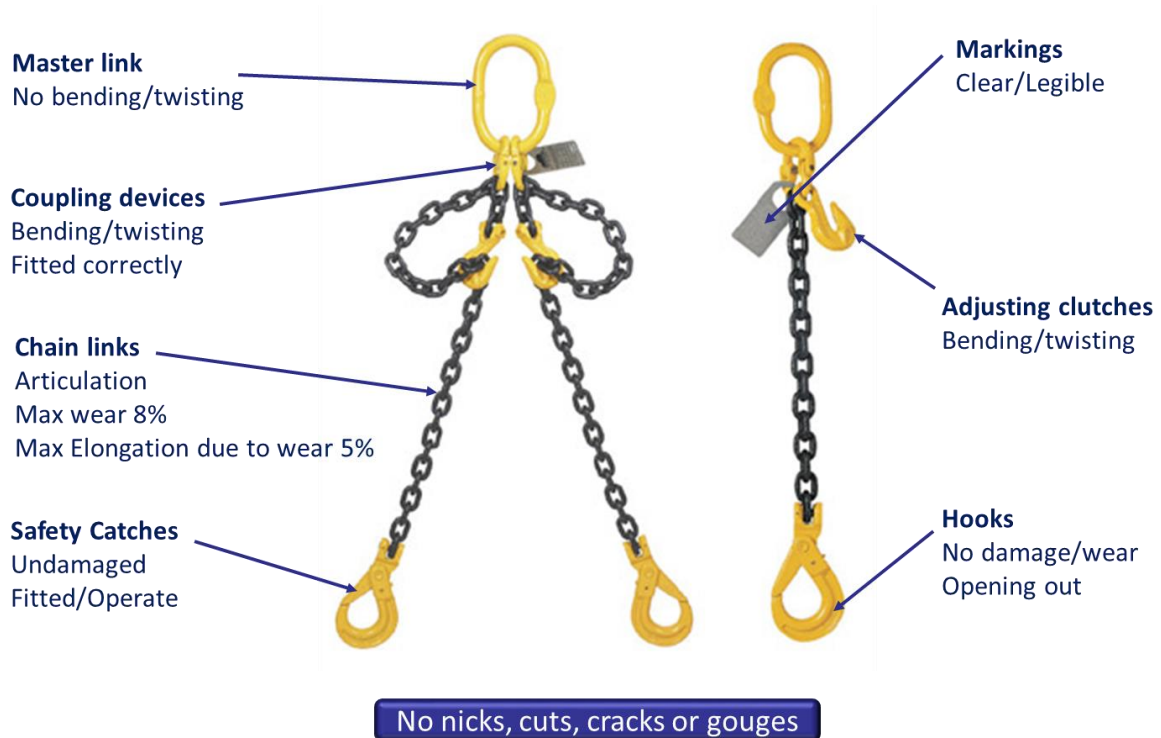

Training

Operative training should take the manufacturer's instructions for and use into account, paying particular attention to the following:

- Due to the multiple applications for which the chain slings are used, the operative may frequently be the person who selects the sling. It is therefore recommended in such cases that all applicable information be available to the operative including this Code of Practice and the manufacturer's instructions

Steel Wire Rope and Wire Rope Slings

Wire rope has sufficient flexibility to run around pulleys and be bent to form eyes, however, it is also the most rigid of the lifting media.

Its rigidity allows it to be passed easily under loads and through apertures, which would not be possible with any of the more flexible lifting media. When in long lengths it is stored on reels, or coiled, and must be handled carefully or it may become damaged.

Wire rope has been in common use since the late 1800's and is a good medium for making slings, which are lighter than the equivalent capacity chain slings.

Due to its construction there are a large number of small wires at the surface and so is more susceptible to damage than chain. Additionally, if a sling is bent around a corner of the load or repeatedly used to lift identical loads, the rope will take on a permanent set.

The following European standards are applicable to wire rope and wire rope slings:

- BS EN 12385 Parts 1 to 4 - Steel Wire ropes – General Requirements, Definitions, Information for use and Maintenance and Stranded ropes for General Lifting Application
- BS EN 13411 Parts 1, 2, 3 and 5 – Terminations for steel wire rope, splicing of eyes, ferrule secured eyes and wire rope grips for eyes
- BS EN 13414 Parts 1 and 2 – Steel wire rope slings and information for use and maintenance
- BS EN 1677 – Components for slings

How Wire Rope is Made

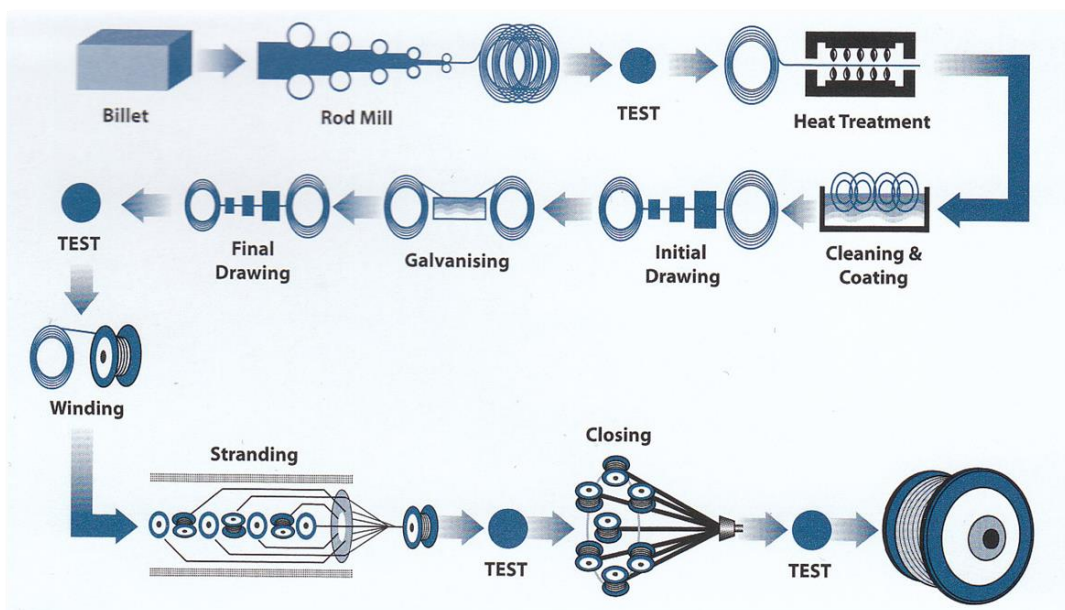

Elements of a Wire Rope

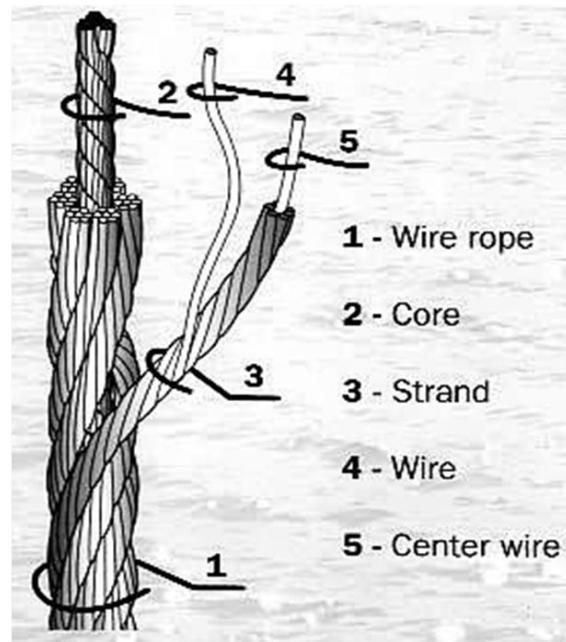

Outer wires – All wires positioned in the outer layer of a spiral rope or in the outer layer of wires in the outer strands of a stranded rope.

Inner wires – All wires of intermediate layers positioned between the centre wire and outer layer of wires in a spiral rope or all other wires except centre, filler and outer wires in a stranded rope .

Filler wires – Wires used in filler construction to fill up the gaps in between the layers.

Centre wires – Wires positioned at the centre of a spiral rope or the centres of strands of a stranded rope.

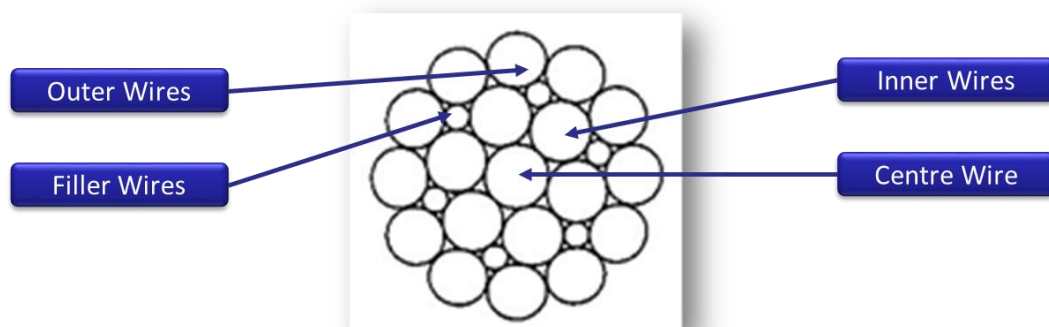

Construction of a Wire Rope

There are many constructions of wire rope which use a variety of wire sections, wire diameters and methods of spinning the wires together to obtain very different characteristics of rope with different properties for specific duties.

For sling manufacture ropes formed from round section wire are used. Although slings can be made from any suitable six or eight stranded ropes, six stranded are by far the more common. We will therefore limit our considerations to six stranded ropes, but note that exactly the same principles apply to eight stranded ropes.

To form the rope, a number of single wires are twisted (laid) together to form a strand. A number of strands are then taken and twisted (laid) together around a core to form the rope.

Strand Construction

A single wire, known as a king wire, is taken and then the remainder of the required number of wires are twisted around this to form a strand.

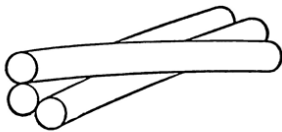

Cross Lay Rope

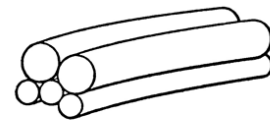

Equal Lay Rope (Parallel)

Wire sizes and the manner in which they are laid up can be adjusted to give varying performance characteristics to the rope for different service duties.

Most common for wire rope for sling manufacture is 6 x 19. However, 6 x 36 is also widely used and other constructions can be employed.

6 x 19 means that there are 6 strands each of 19 wires and 6 x 36 means that there are 6 strands each of 36 wires. Both of these are equal lay ropes.

This illustration shows a wire rope construction made of 6 outer strands with each outer strand made up of 19 wires.

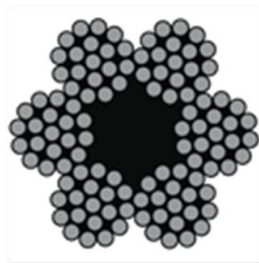

6 x 19 Construction

3 Basic Methods of Laying up a Strand of Wire Rope

Seale Construction



Warrington Construction

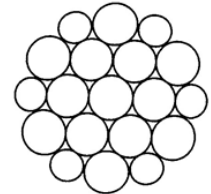

Filler Construction

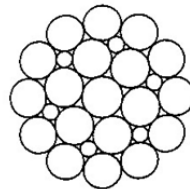

Seale Construction – this is a parallel lay strand with the same number of wires in both layers.

In the example shown opposite, the construction consists of 1 x Centre wires, 9 x Inner wires and 9 x outer wires.

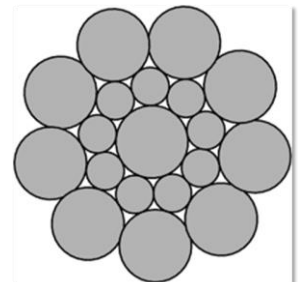

Warrington Construction – a parallel lay strand having an outer layer containing alternately large and small wires.

In the example shown opposite, the construction consists of 1 x Centre wires, 7 x Inner wires and 14 x outer wires.

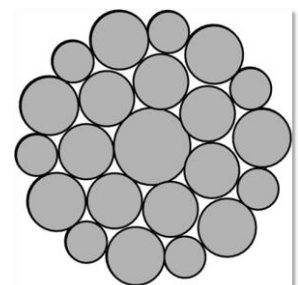

Filler Construction – a parallel lay strand having an outer layer containing twice the number of wires than the inner layers with filler wires in the valleys between the layers.

In the example shown opposite, the construction consists of 1 x Centre wires, 6 x Inner wires, 6 x Filler wires and 12 x outer wires.

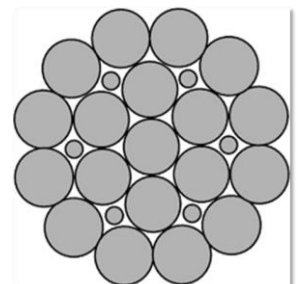

Combined Construction – a parallel lay strand having three or more layers laid in one operation and formed from a combination of the previous strand types.

In the example shown opposite, the Warrington Seale construction consists of 1 x centre wire, 6 x inner wires, 12 x warrington wires and 12 x outer wires.

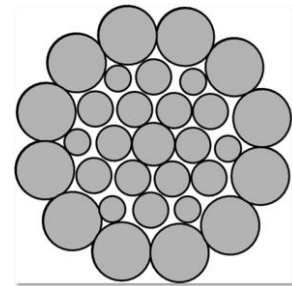

Types of Wire Rope Core

Fibre core – (FC) core made from either natural fibres or synthetic fibres.



Wire Stranded Core – (WSC) this type of core can be either one single wire as the core or more typically the core construction the same as the outer strands.

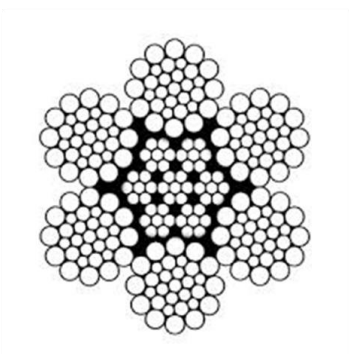
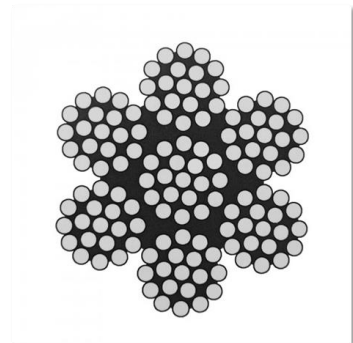

Independent Wire Rope Core – (IWRC) this type of core is actually made up of a core and strands so is actually a rope that is utilised as the core.

Grades of Wire Rope

Wire tensile strength/grade – The grade of the wire rope based upon the tensile strength of the wires in N/mm².

Rope Grade	Wire tensile strength grade	
	Minimum	Maximum
1770	1570	1960
1960	1770	2160
2160	1960	2160

Wire Rope Finish

Coatings and plating are added to wire to provide protection such as galvanising (a surface coat of zinc is given to the wire). This coating will resist oxidation which will improve the corrosion resistance of the wire rope.

BS EN 12385 uses the symbol 'U' to denote uncoated or bright finish.

For zinc coating the symbol will depend on the class of the coated finish:

- Class B zinc coating is designated 'B'
- Class A zinc coating is designated 'A'

Stranding

The stranding operation takes place when all the wires are brought together at the forming point. Note that the wires during this and the closing operation the wires are spun in to the correct helical shape, this process is called preforming. This reduces the internal stresses in the strands and the rope meaning that if the wires and strands are cut they do not spring out of the rope formation.



Prefforming

During this operation, the strands are now brought together at the forming point around the specified core to make the rope.

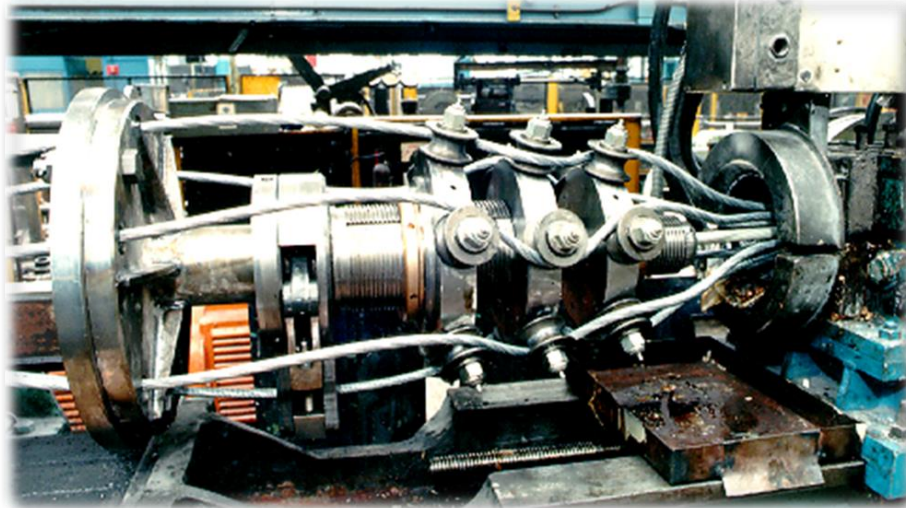

The individual wires in the strand are bent into the correct helix before being wound into position. The strands are then wound into the correct helix, generally the opposite direction.

- Results in a relatively inert (dead) rope
- Resistant to kinking
- Easy to handle so when such a rope is cut:
 - Wires will stay in position
 - Broken wires do not stick out
 - Less dangerous to the user
- Rope is more flexible

Notes:

Rope Lay

Rope lay refers to the way in which the wires are laid when forming the strands and the way in which the strands are laid when forming the rope.

There are 2 types of lay, ordinary (regular) lay and Lang's lay:

Ordinary lay – The wires that make up the strand and the strands that make up the rope are laid in opposite directions. When formed, this gives the impression that the wires are running the length of the wire rope.



Lang's lay – The wires that make up the strand are laid in the same direction as the strands in the rope. When formed the wires quite clearly run across the diameter of the rope. Due to the tendency of the rope to unwind, Lang's lay ropes are not suitable for wire rope slings.



Ordinary lay

Wires in the strands are laid in the opposite direction of lay to the strands in the rope.

The lower case letter indicates the direction of the wires and the capital letter, the direction of the strands.



Lang's lay

Wires in the strands are laid in the same direction of lay as the strands in the rope.

NOT suitable for the manufacture of wire rope sling legs.



Rope Details and Designation

The following is a list of typical information that might be required with the rope:

- Length of rope
- Standard to which the rope conforms
- Nominal diameter of rope*
- Construction of rope*
- Type of core*
- Grade of rope*
- Wire finish*
- Direction of lay and type of lay*
- If the rope is preformed
- If special lubrication has been applied
- Minimum breaking load

*BS EN 12385-2 requires the designation to be made up of the six pieces of information indicated above.

Example: A 20mm diameter right hand ordinary lay wire rope of 6 x 36 Warrington-Seale construction with a wire core made in 1770 grade wire with a bright finish. Following BS EN 12385 the designation will then be: 20 6x36WS-IWRC 1770 U sZ.

	22 6x36WS-IWRC	1770 B	sZ
	32 18x19S-WSC	1960 U	sZ

sZ = Right Hand Ordinary Lay Rope

The first letter denotes strand direction;
the second letter denotes rope direction.

Key

feature:

a) dimension(s) _____

b) rope construction _____

c) core construction _____

d) rope grade, where applicable _____

e) wire finish _____

f) lay type and direction _____

Notes:

Wire Rope Slings

Wire rope slings give the user a versatile and safe means of connecting loads to lifting appliances, provided that they are used in the correct manner and dangerous lifting practices and service damage are avoided.

In many cases the use of a wire rope sling in preference to, for example, a chain sling is a matter of the personal choice of the user. There are however applications where wire rope slings are preferred to other types of sling and similarly there are applications where other types of slings may be preferable to wire rope slings.

BS EN 13414-1: 2003 + A2: 2008 – Steel wire rope slings – Safety – Slings for general service is a harmonised European standard and replaces BS 1290. There are several differences between these two standards which should be noted: BS EN 13414-1 rates slings at a factor of safety of 5:1 after taking account of the termination efficiency whereas BS 1290 applied a factor of 5:1 to the rope thus giving a factor of 10-20% less when termination efficiency is taken into account.

BS EN 13414-1: 2003 + A2: 2008 permits rope of both **1770** and **1960** grade to be used.

When first published it required slings made of 1960 grade rope to be rated as if made from 1770 grade rope.

An amendment has since been passed to allow full advantage to be taken of 1960 grade rope.

BS EN 13414-1 calls for multi-leg slings to be rated and marked with their WLL expressed in terms of the inclination angle to the vertical, e.g. 0-45°.

Eye Terminations

Single slings are produced by taking a length of wire rope and forming an eye at each end.

Multi-leg slings are made in exactly the same way except that the eyes at the top of the sling are made through a master link.

If terminal fittings are required, these can be attached by making the eye through the fitting. To help the eye keep its shape and to give the rope protection a thimble is used (see BS EN 13411-1). This is often known as a 'hard eye' and this is advised when fittings are to be made onto the sling as permanent attachments.

Notes:

Thimbles

BS EN 13411-1: Thimbles of any size shall comply with the following dimensions:

- 2.5 to 3.5 x rope diameter (dimension 1)
- 1.5 to 2 x dimension 1
- Angle $\leq 50^\circ$

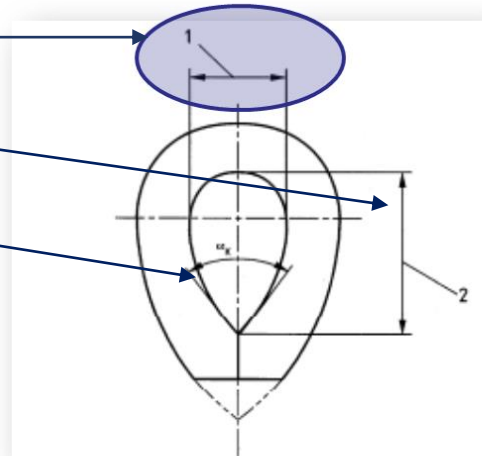

Thimbles are to be visually inspected for surface defects liable to damage the rope or injure the user.

Eye Terminations

There are two ways that eyes can be made, ferrule secured (sometimes incorrectly referred to as a mechanical splice) and hand spliced. BS EN 13414-1 does not specify how to make these eye terminations, but requires them to be made in accordance with BS EN 13411-2 and 3.

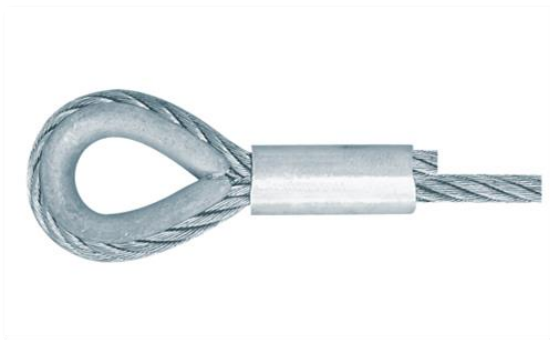

Ferrule Secured

Hand Spliced



Notes:

Ferrule Secured Eyes

There are two ways that ferrule secured eyes can be formed, the turn back loop and the Flemish eye. BS EN 13411-3 gives the requirements, including the verification necessary, for both of these methods.

Turn Back Loop

The turn back loop is the cheaper option to manufacture and therefore is perhaps used more commonly for general purpose slings. With this method, an aluminium ferrule is used to secure the eye made in the end of the rope.



Cross- Section of a Pressed Ferrule Termination

The eye is simply formed by passing the ferrule over the rope, bending the rope back on itself to form the eye, pulling the ferrule back over the returning tail end of the rope and then pressing the ferrule. Under pressure the aluminium flows into the rope formation, making a homogeneous joint.



Ferrules

Ferrules are made from different materials for different types of rope.

There is also different shapes of ferrules for the different types of termination.

The standard, BS EN 13414 -1 recognises the differing methods of terminating a wire rope, but gives the same termination efficiency for all ferrule secured terminations of 90%.



Dies and Ferrules



Various Die Blocks



Various Ferrules

Turn Back Loop

When square cut ferrules are used, in order to ensure that the rope is fully engaged within the ferrule it is necessary for a small amount of the tail to protrude through the ferrule. The standard says that the length of this should be no more than one half of the rope diameter. However, if the rope has been cut by a heat process a portion of the rope will have become annealed (softened) in the heat affected area. The protruding tail in this case should be no more than an amount equal to one diameter of the rope, and positioned so that none of the annealed section is within the ferrule.

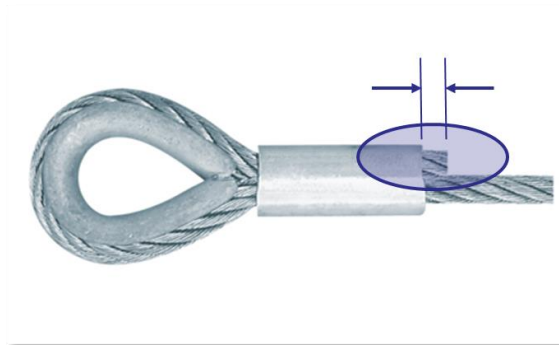

Tapered ferrules are also available from some manufacturers. In this case the tail end remains within the ferrule and it is essential that the ferrule manufacturer's instructions for fitting are followed. Often, the manufacturer of the ferrule will provide a small view hole in the ferrule to enable the tail end to be seen.



Soft Eye

A simple loop in the wire, with no protective thimble, is known as a soft eye.

BS EN 13411-3 requires the length of the soft eye (h) to be at least fifteen times the diameter of the rope and the width ($h/2$) to be half the length of the eye, as illustrated below:

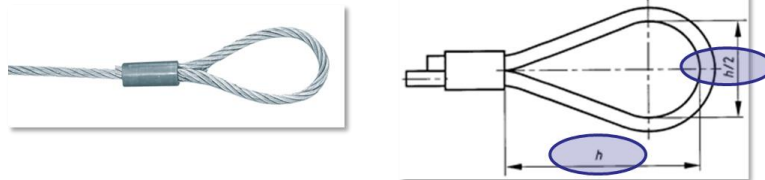

Sling Terminations

When a thimble is fitted, the size and shape of the correctly sized thimble will dictate the length and width of the eye.

Typically after pressing the clearance between the base of the thimble and the ferrule should be approximately 1.5 times the nominal rope diameter for a thimble without a point, and 1 times the nominal diameter for a thimble with a point unless specified otherwise by a competent person.

Note: Upper eyes shall always be fitted with thimbles, and if lower terminal fittings are used, the eyes shall always be fitted with thimbles.

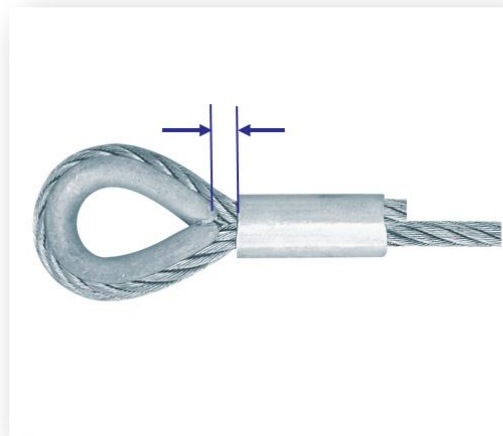

Flemish Eye

This method of making an eye actually produces a stronger securing than the turn back loop, i.e. the termination is more efficient. It takes longer to produce and is therefore more expensive. In this case, a steel tapered ferrule is used to secure the exposed ends of the rope.



To make a Flemish eye, a tapered steel ferrule is passed over the rope. The standing part of the rope is then taken and three strands are unravelled and opened so that a 'Y' formation is made. Care has to be taken to ensure that the strands still lay together as they had in the rope.

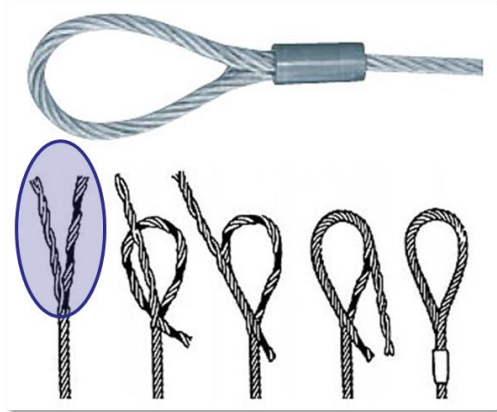

Hand Spliced Terminations

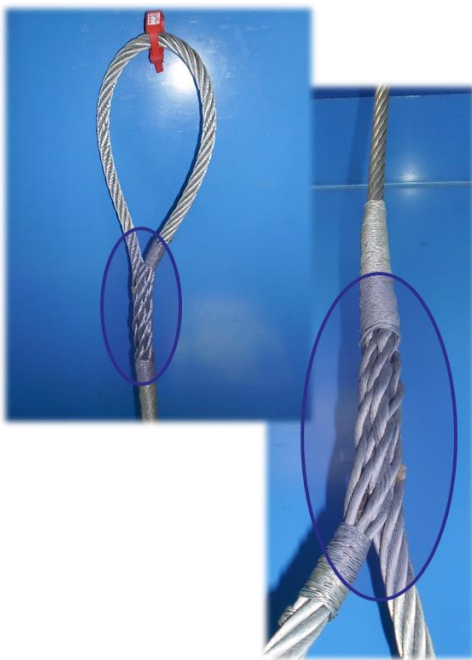

Spliced terminations must be carried out by a trained splicer.

When a spliced termination is utilised, the termination efficiency of 80% is used.

The splice shall have at least five load carrying tucks from which the name five tuck splice is taken. These can also be known as a "dock splice" and these splices must be made against the lay of the rope.

At least 3 of these load carrying tucks must be made with the whole strand, the remainder can be made with at least 50% of the wires in the strand. This then gives a taper to the lower part of the splice.

Protruding Wires

Any protruding wires must be addressed; for example by serving, reinsertion of the tails back into the rope, or by covering with heat shrink wrapping. Where used, serving or wrapping shall not cover the three full strand load carrying tucks.

Verification of the Safety Requirements:

- Qualification of Personnel
 - Any person verifying the splice shall be a competent person
- Number of Tucks
 - The requirements of the number of tucks shall be confirmed by visual inspection

- Direction of the Tucks
 - The direction of the tucks shall be confirmed by visual inspection
- Protruding Wires
 - The splice shall be visually inspected to ensure that the tails of the tucks do not protrude outside of the rope

Steel Wire Rope Sling for General Lifting Service

Assembly of components which includes one or more single part legs or an endless sling which is intended for a variety of lifting operations and not designed for one specific lifting application.



Terminal fittings

Link, link assembly, hook or other device permanently fitted at the upper or lower end of a sling and intended to connect the sling to the load or the lifting machine.



Master Link Assembly



Hooks with Safety Latches

Notes:

Intermediate master link

Link used to connect one or two legs of a sling to a master link.

Note:

Intermediate links can be assembled with a master link to form a permanent master link assembly.

BS EN 13414 -1 states that in a three-leg sling, two of the legs shall be joined by a single intermediate master link to the master link, the third leg shall be connected via a second intermediate master link. In a four-leg sling each of the two pairs shall be joined by an intermediate master link to the master link.



Be aware that some other global standards do not have this requirement and you can find a single master link with all 3 or 4 legs attached.

Uniform Load Rating of a Wire Rope Sling

It has been common practice in the past to calculate the working load limit of a multi-leg sling by reference to either prepared tables or basic mathematics taking account of the angle to the vertical for each leg of the sling. Thus the working load limit of a sling rated by this method is a variable dependent on the angle to the vertical of each leg such that as the angle increases the working load limit of the sling decreases.

The method of rating slings for general service used in BS EN 13414 -1 removes the need for calculation or the use of tables since the sling has a fixed working load limit for a given range of angles. The working load limit of the sling does not increase as the angle to the vertical decreases. Hence a sling has a fixed working load limit at all angles between 0° and 45° and the same sling has a lesser working load limit at all angles between 45° and 60°.

Since the upper terminal of the sling assembly, e.g. a master link, will have been selected to match the stated working load limit of the sling, the sling should not be re-rated by the traditional method for angles smaller than the maximum quoted since the upper terminal will not be strong enough.

Notes:

Safety Requirements

Grade of Rope

The rope grade shall be either 1770 or 1960.

Ferrule-Secured Eye Slings

Ferrule secured eyes shall conform to BS EN 13411-3.

The minimum length of plain rope between the inside ends of ferrules (1) terminating a sling leg shall be 20 times the nominal rope diameter.

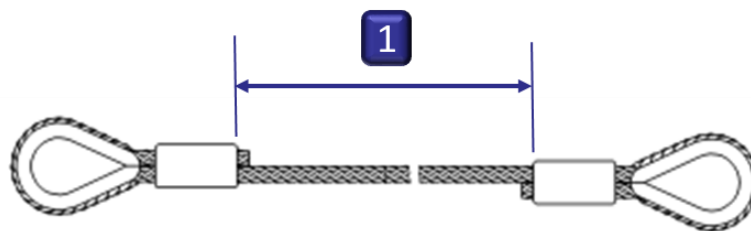

Spliced Eye Slings

Spliced eyes shall conform to BS EN 13411-2.

The minimum length of plain rope between the tails of splices (1) shall be at least 15 times the nominal rope diameter.

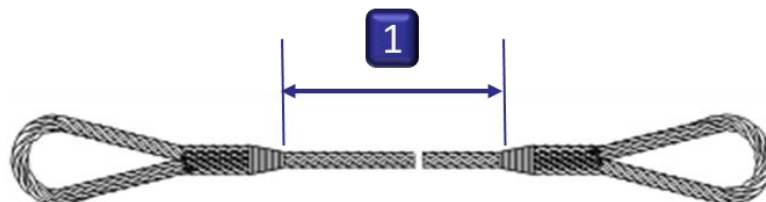

Hard Eyes

Hard eyes shall be fitted with thimbles conforming to BS EN 13411-1 and assembled in accordance with the ferrule secured eye termination (FSET) designer's instructions.



Soft Eyes

The peripheral length of a soft eye shall be at least four rope lay lengths.



Note: A stirrup can be fitted to protect the bearing surface of the soft eye.



Terminal Fittings

The working load limit of any master link shall be at least equal to that of the sling.

The working load limit of any intermediate link fitted to a three-leg or four-leg sling shall be at least equal to 1.6 times the WLL of one of the legs suspended from it.

The working load limit of the lower terminal fitting(s) shall be at least equal to that of the leg(s) to which it is/they are fitted.

Where forged steel lifting hooks with latch – grade 8, forged steel self-locking hooks – grade 8, links – grade 8, forged steel lifting hooks with latch – grade 4, links – grade 4 are used, they shall conform to EN 1677 parts 2 to 6 respectively.

Where shackles are used they shall conform to EN 13889.

Single Leg Slings

Single-leg slings shall be one of the types shown in the table below, with or without terminal fittings such as links or hooks.

Terminal fittings		
At upper end	At lower end	
 Link	 Shackle	 Hook
	 Link	

Form of sling leg			
Ferrule-secured hard eye	Hand spliced soft eye	Ferrule-secured soft eye with stirrup	Ferrule-secured soft eye

Where a terminal fitting is used, the eye termination shall always be fitted with a thimble.

Length

The length shall be that measured between the bearing points of the sling.

The measured length of a ferrule-secured sling shall not differ from the nominal length by more than two rope diameters or 1 % of the nominal length, whichever is the greater.

The measured length of a spliced sling shall not differ from the nominal length by more than four rope diameters or 2 % of the nominal length, whichever is the greater.

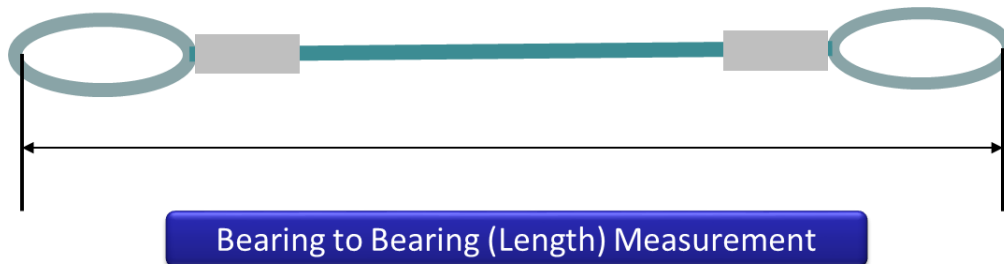

Length of Matched Sets

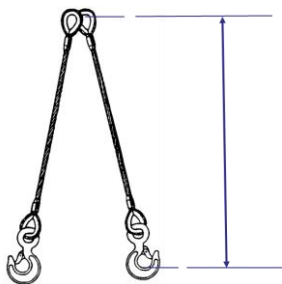

Where single leg slings are intended to be used as matched sets, the difference in length of matched sets of ferrule-secured eye slings shall not exceed the rope diameter, or 0.5 % of the nominal length, whichever is the greater.

100

Multi – Leg Slings

Length

The length shall be that measured between the bearing points of the sling.

The measured individual leg lengths shall not differ from the nominal length of the sling by more than two rope diameters or 1 % of the nominal length, whichever is the greater.

The difference in length between the individual legs of any multi-leg sling under no load shall not exceed 1.5 times the rope diameter or 0.5 % of the nominal length, whichever is the greater.

Notes:

Formation of a Sling

The rope size type and grade for each leg shall be the same.

The legs of two-leg slings shall be joined at their upper ends by a master link.

In a three-leg sling, two of the legs shall be joined by a single intermediate master link to the master link, the third leg shall be connected via a second intermediate master link. In a four-leg sling each of the two pairs shall be joined by an intermediate master link to the master link.

Upper eyes shall always be fitted with thimbles, and if lower terminal fittings are used, the eyes shall always be fitted with thimbles. Thimbles shall conform to EN 13411-1.

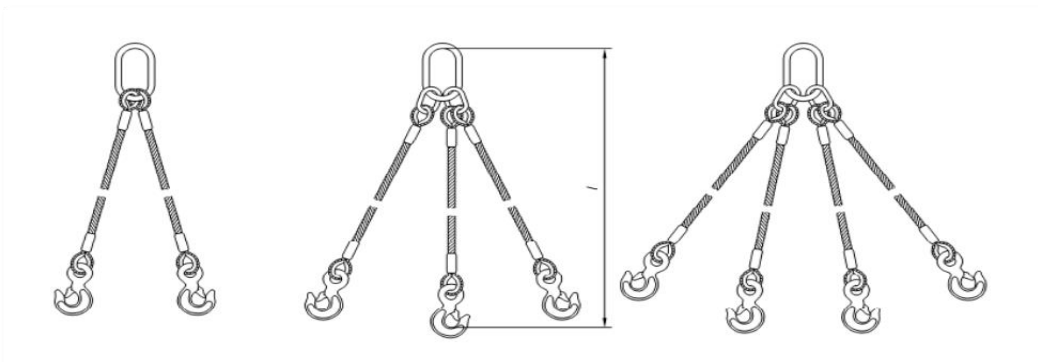

As mentioned previously, some standards allow all the legs of a 3 or 4 leg sling to be joined by a single master link. Before the rejection of such slings, reference should always be made to the certification of the sling to verify the standard. **This is not accepted by BS EN 13414-1.**

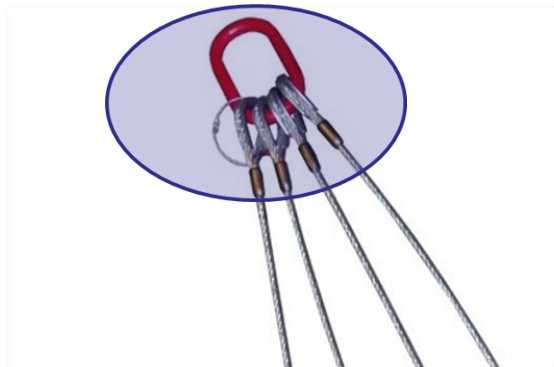

Notes:

Example WLL for slings using steel core rope in grade 1770 and having ferrule-secured eye terminations (8mm to 12mm diameter):

	1 Leg Sling	2 Leg Sling		3/4 Leg Sling		Endless Sling
Angle to the Vertical	0°	0-45°	45-60°	0-45°	45-60°	0°
	Direct	Direct		Direct		Choke
Nominal Diameter	WLL (t)					
8	0.75	1.05	0.75	1.55	1.1	1.2
9	0.95	1.3	0.95	2.0	1.4	1.5
10	1.15	1.6	1.15	2.4	1.7	1.85
11	1.4	2.0	1.4	3.0	2.12	2.25
12	1.7	2.3	1.7	3.55	2.5	2.7

Example WLL for slings using steel core rope in grade 1770 and having ferrule-secured eye terminations (22mm to 32mm diameter):

	1 Leg Sling	2 Leg Sling		3/4 Leg Sling		Endless Sling
Angle to the Vertical	0°	0-45°	45-60°	0-45°	45-60°	0°
	Direct	Direct		Direct		Choke
Nominal Diameter	WLL (t)					
22	5.65	7.8	5.65	11.8	8.4	9.0
24	6.7	9.4	6.7	14.0	10.0	10.6
26	7.8	11.0	7.8	16.5	11.5	12.5
28	9.0	12.5	9.0	19.0	13.5	14.5
32	11.8	16.5	11.8	25.0	17.5	19.0

Verification of Wire Rope Slings

Components of the Wire Rope Sling

The suppliers' records shall be used to confirm that the verification clauses of BS EN 12385-1, BS EN 1677 Parts 1 to 6, BS EN 13411-2 and BS EN 13411-3 have been satisfied for the wire rope, hooks and links, and spliced and or ferrule secured terminations from which the sling is formed.

Rope Construction

The suppliers' records shall be used to verify the rope construction, diameter and grade of rope used.

Length of the Sling

The length of a single leg sling and the length of the individual legs of multi-leg slings shall be measured without load and with the widths of soft eyes being approximately half their length.

WLL of Terminal Fittings

The suppliers' records shall be used to verify the WLL of terminal fittings used in the construction of the sling.

Formation of a Multi-Leg Sling

The requirements of the Standard shall be confirmed by visual inspection.



Marking Requirements

General

Each sling shall be legibly and durably marked with the information listed below:

Single-leg sling (single part or endless)

- The sling manufacturer's identifying mark
- Numbers and/or letters identifying the sling with the certificate conforming to the certification of the sling
- The working load limit
- Legally required markings, e.g. year of manufacture, grades, CE, etc. (refer to LEEA 059-5 Guidance Document)

General

Each sling shall be legibly and durably marked with the information listed below:

Multi-leg sling

- The sling manufacturer's identifying mark
- Number and/or letters identifying the sling with the certificate conforming to the sling certification
- The working load limits and the angles applicable, i.e. the WLL 0° to 45° to vertical and, additionally, the WLL 45° to 60° to the vertical if applicable
- Legally required markings, e.g. year of manufacture, grades, CE, etc. (refer to LEEA 059-5 Guidance Document)

Certification Requirements

A certificate shall be supplied with each sling or batch of slings. This shall identify the sling with the certificate and include a statement that the sling conforms to BS EN 13414-1

The certificate shall contain at least the following information:

- The name and address of the manufacturer or where applicable the authorized representative
- The number and part of this European Standard i.e. BS EN 13414-1
- The description of the sling including all component parts
- The WLL and the appropriate angle(s) to the vertical for multi-leg slings
- The static test coefficient(s) used for design of component(s) (e.g. hook; link; shackle)

Notes:

Safe Use of Wire Rope Slings

In addition to any specific instructions relating to the safe use of the wire rope sling issued by the manufacturer, the following points should be observed:

- The sling must not be used to lift a load that is in excess of the safe working load marked upon the sling, taking account of the slinging mode. In addition to selecting a suitable sling, ensure that the lifting machine or appliance is adequate to lift the load
- Care must be taken to ensure the compatibility of any ancillary equipment used to sling the load, both in size and capacity. Where more than one sling is used to lift the load, each sling should be adequate for the share of the load imposed on it taking into account the slinging method
- As far as is reasonably practicable, the effective diameters of pins, hooks or other components over which soft eyes are used should not be less than twice the diameter of the rope in the case of single part slings or four times the diameter of the rope in the case of double part slings. Where necessary, an intermediate component of adequate size should be used to ensure this
- The upper terminal of the sling should be seated in the bowl of the crane hook, never on the point, nor wedged in the throat. Master links should be free to articulate at all times so as to avoid deformation of the master link or the crane hook. Safety catches, where fitted, must be free to operate. It is good practice when using more than one sling to join them with a shackle before placing them onto the hook
- The joining together of wire rope slings made from rope of different lay directions must never be considered since this may cause the ropes to un-lay, thus seriously affecting the capacity of the slings
- Wire rope slings have very different stretch characteristics to those of other lifting media such as webbing slings. Their use in parallel with such slings to form multi-leg assemblies should therefore be avoided as the unequal stretch of the legs can lead to load instability. However this is not intended to preclude their use combined in series as a means of connecting a sling to the load which can be advantageous in some circumstances
 - For example, a webbing sling can be wrapped and choked onto a polished surface then hooked into a wire rope sling thus gaining the advantage of the webbing protecting an easily damaged surface

- Care must be taken to position the slings correctly. Wire rope performs best when it supports a load in a straight line. It is however a flexible medium and may be used to wrap, either fully or in part, around loads as in choke hitch or basket hitch. Where this is the case, the rope should form as large a radius as possible having a smooth curve. In any circumstances, the radius formed should never be less than four times the diameter of the rope. Use packing protection, e.g. old tyres, to prevent cutting damage to the sling, this will also help the rope to form smooth curves (see illustration below) Attention to these points will prolong the service life and avoid permanent kinking of the rope

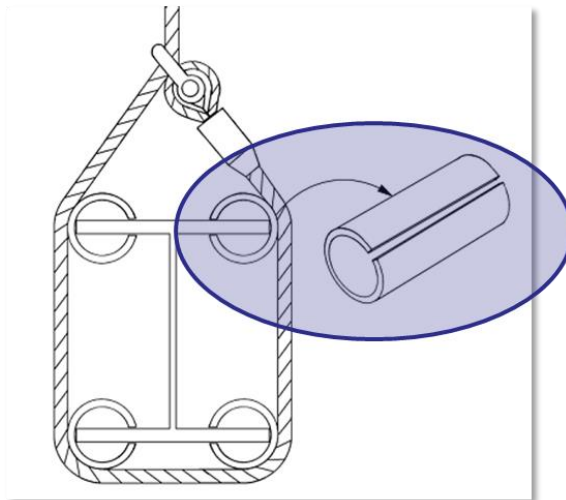

- When positioning endless slings, care must be taken to ensure splices and ferrules are kept away from the load, the hook and the choke. They should be placed in the freestanding part of the rope
- Sling hooks of multi-leg slings should be positioned so that they face outward from the load, without inducing a twist in the rope



- If, during a trial lift the load is found to be out of balance, it should be lowered and the slings repositioned. Never reposition wire rope slings by hammering, either to bring an out of balance load into balance or, in the case of choke hitch, to tighten the bight. When used in choke hitch, the bight should be positioned so as to assume the natural position, i.e. the three parts of rope being 120° apart. Unlike chain slings with clutches, wire rope slings cannot be adjusted, so in some cases it may be necessary to change the slings for ones of a different length or to select another slinging method
- When used in basket hitch, single leg slings should preferably be used in pairs with a spreader beam, unless the rope passes through the load making it captive as shown in the illustration below. Multi-leg slings used in basket hitch without a spreader may be prone to slippage and consequent imbalance or dropping of the load

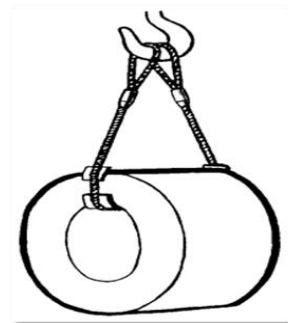

- Great care should be taken to avoid shock loading as it effectively increases the weight of a load and could result in the lifting equipment being grossly overloaded. In the case of wire rope, this can result in internal, and therefore unseen, damage
- Wire rope slings which have been in service for long periods of repetitive lifting around loads, e.g. in choke hitch, may become bent or set. To some degree, this is unavoidable and may have no detrimental effect on the use of the sling. However such slings may become difficult to handle and further deterioration will take place. These slings call for careful handling and a more detailed inspection prior to each lift. Refer defects to the Competent Person
- A small number of well distributed broken wires is acceptable in many cases and will have no effect on the capacity of the sling, but they do present a danger to the operative when handling the sling if they protrude. Similarly, the necessary tail of exposed wire ends from square ferrules can also present a hazard to the operative. Wire rope slings should therefore be handled with care and it is advisable that suitable protective gloves are worn at all times. When protruding barbs of broken wires are found, the sling should be referred to the Responsible Person for attention

Notes:

Multi-leg wire rope slings with less than the full number of legs in use

As a general principle, wire rope slings should be used only for the purpose for which they have been designed. In practice, however, occasions may arise when a lift needs to be made using a smaller number of legs than the number of legs in the sling. In such cases the WLL should be reduced from that marked on the sling by applying the relevant factor given in the table below from the LEEA COPSULE:

Total Number of Legs	Number of Legs in Use		
	1	2	3
2	1/2	1	n/a
3	1/3	2/3	1
4	1/4	1/2	3/4

Legs that are not in use should be hooked back to reduce the risk of such legs swinging freely, or snagging when the load is moved.

Use in Adverse Conditions

High and Low Temperatures

Account should be taken of the maximum temperature that can be reached by the wire rope sling in service. This is difficult in practice but underestimation of the temperature should be avoided.

The use of wire rope with a WIRE CORE to produce slings with either HAND SPLICED OR STEEL FERRULE SECURED EYES enables them to be used at temperatures up to 400°C. However, a reduction in strength occurs necessitating a reduction in SWL as shown in the following table:

Temperature	Reduction in SWL
Up to 100°C	No reduction
100 to 200°C	10%
200 to 300°C	25%
300 to 400°C	35%
Above 400°C	Not recommended

De-Rating Slings due to Temperature

Termination type	Ferrule material	Rope core	De-rated working load limit expressed as % of WLL of the sling					
			Temperature, T, °C					
			40<T≤100	100<T≤150	150<T≤200	200<T≤300	300<T≤400	400<T
Turn-back eye	Aluminium	Fibre	100	Do not use	Do not use	Do not use	Do not use	Do not use
Turn-back eye	Aluminium	Steel	100	100	Do not use	Do not use	Do not use	Do not use
Flemish eye	Steel	Fibre	100	Do not use	Do not use	Do not use	Do not use	Do not use
Flemish eye	Steel	Steel	100	100	90	75	65	Do not use
Hand splice	-	Fibre	100	Do not use	Do not use	Do not use	Do not use	Do not use
Hand splice	-	Steel	100	100	90	75	65	Do not use

The use of wire rope slings within the permissible temperature ranges given in table above does not require any permanent reduction in working load limit when the rope is returned to ambient temperature.

Wire rope slings will not be adversely affected by temperatures down to -40 °C and no reduction from the working load limit is necessary, therefore, on this account. Where wire rope slings are to be used at temperatures below -40 °C the manufacturer should be consulted.

Acidic/Alkalic Conditions

Wire rope slings should not be used either immersed in acidic/alkalic solutions or exposed to acid fumes.

Attention is drawn to the fact that certain production processes involve acidic/alkalic solutions, fumes and sprays and in these circumstances the manufacturer's advice should be sought.

Conditions in which the sling is likely to be subjected to attack (chemical, abrasive, etc.)

The manufacturer of the sling should be consulted, particularly if the sling is to be exposed to chemicals combined with high temperatures.

Use in Hazardous Conditions

The rating of slings for general lifting service excludes hazardous conditions including offshore activities, the lifting of persons and lifting of potentially dangerous loads such as molten metals, corrosive materials or fissile materials. In such cases the degree of hazard should be assessed by a competent person and the working load limit adjusted accordingly.

Classified Atmospheres

Due to the possibility of sparking, the use of aluminium is restricted in certain classified atmospheres. Care must therefore be taken when selecting wire rope slings with ferrule secured eyes for use in such areas to ensure the suitability of the ferrule material.

In-Service Inspection

General

During service, wire rope slings are subjected to conditions that affect their safety. It is necessary, therefore, to ensure, as far as is reasonably practicable, that the sling is safe for continued use.

The sling should be inspected for any obvious signs of deterioration before each use.

If, at any time there is reason to doubt the safe condition of the sling, it should be withdrawn from service and subjected to a thorough examination.

If the tag or label identifying the sling and its working load limit becomes detached and the necessary information is not marked on the master link, or by some other means, the sling should be withdrawn from service.

An inspection is a visual check on the condition of the sling to identify any obvious damage or deterioration that might affect its fitness for use.

The sling should be withdrawn from service and referred to a competent person for thorough examination if any of the following is observed before each use:

- Illegible sling markings, i.e. sling identification and/or working load limit
- Wear, distortion and/or cracking of the upper or lower terminals and/or ferrules
- Concentration(s) of broken wires
- Severe rope distortion, such as kinks or protrusion of the core
- Significant rope wear
- Corrosion
- Heat damage

Maintenance

Any replacement component or part of the wire rope sling should be in accordance with the appropriate European Standard for that component or part.

Components that are cracked, visibly distorted or twisted, severely corroded or have deposits that cannot be removed.

Minor damage such as nicks and gouges to terminal fittings may be removed by careful grinding or filing. The surface should blend smoothly into adjacent material without abrupt change of section. The complete removal of the damage should not reduce the thickness of the section at that point to less than the manufacturer's specified minimum dimensions or by more than 10% of nominal thickness of the section.

The Thorough Examination

A thorough examination should be carried out at intervals not exceeding 6 months in accordance with LOLER. This interval should be less where deemed necessary in the light of service conditions.

To facilitate examination, slings may need to be cleaned so as to be free from oil, dirt and rust prior to examination.

This can usually be accomplished by using a wire brush. Other methods may be used providing that the parent metal is not damaged. Methods to avoid are those using acids, overheating or removal of metal.

Records of such examinations should be maintained in accordance with LOLER Regulation 11 for a minimum period of 2 years.

Markings

The sling should be withdrawn from service if the sling markings, i.e. information on the sling identification and /or the working load limit, are illegible.

Marking should be by means of a suitable plate or metal tab permanently attached or by stamping directly into the equipment, preferably in a non-load bearing or low stress area. Stamping into a stressed area

may also be permissible provided that the mechanical properties of the component are not significantly impaired. Where applicable, the position and size of stamping should be as indicated in the relevant standard. When a plate or tag is used to convey this information, it is recommended that the identification mark should also be put directly onto the equipment so that in the event of the plate or tag becoming detached, the identity is not lost and the other information can be recovered from the related documentation.

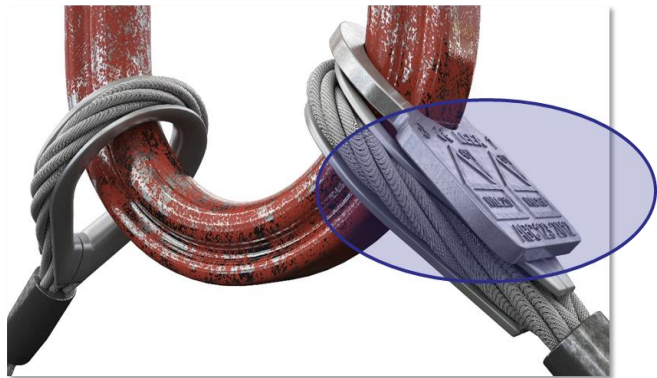

Single Leg Sling (Single Part or Endless)

- CE Mark
- Manufacturers identifying mark
- Numbers and/or letters identifying the sling with the manufacturer's certificate.
- Working load limit
- Year of manufacture
- Material grades

Multi-Leg Sling

- CE Mark
- Manufacturers identifying mark
- Numbers and/or letters identifying the sling with the manufacturer's certificate
- Working load limit and the angles applicable.
- Year of manufacture
- Material grades

Damage to Upper and Lower Terminals

The sling should be withdrawn from service if there is wear, distortion or cracking of the upper or lower terminals.

Note: Particular attention should be paid to signs of opening up, distortion or cracking of the hook, distortion and wear of links or the closing of the thimble, indications that the sling may have been

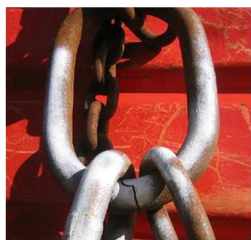

Cracked Master Link



Crushed Thimble



Stretched Hook

overloaded.

Damaged Rope Terminations

The sling should be withdrawn from service if there is wear, distortion or cracking of the ferrules or the pulling out of a splice. Thimble distortion is also cause for withdrawal from service.



Damaged Reeving Thimble

Broken Wires

Broken wires are detrimental because of:

- The possibility of injury to the user's hands
- The loss of strength in the rope

Broken wires are usually caused by mechanical damage, although corrosion may also be a factor.

NOTE: To prevent injury to the user's hands, protruding broken wires can be broken off in the valleys between the strands by reverse bending the wire, with the help of pliers, until fracture occurs. Such actions should be recorded.

Randomly Distributed Broken Wires

6 randomly distributed broken outer wires in a length of $6d$ but no more than 14 randomly distributed broken wires in a length of $30d$ where d is the nominal rope diameter.

Concentrated Broken Wires

3 adjacent broken outer wires in one strand.

Notes:

Rope Distortion

Kinking, crushing, bird-caging or core protrusion or other damage which distorts the rope structure.

NOTE: The main thing to look for is wires or strands that are pushed out of their original positions in the rope. Slight bends in a rope where wires or strands are still relatively in their original positions would not be considered serious damage.



Kink



Wire Protrusion

Rope Wear

The sling should be withdrawn from service if there is wear above 10% of the nominal rope diameter.

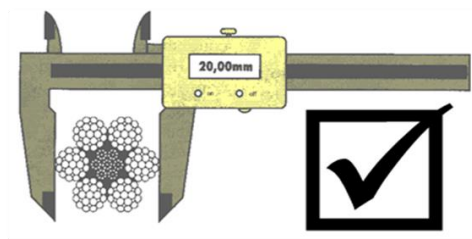
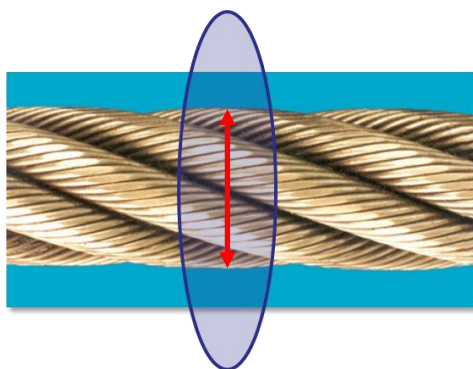

Corrosion

Pitting of the wires or loss of flexibility of the rope due to severe internal corrosion.

Note: Corrosion may occur where slings have been improperly stored or have been used in particularly corrosive conditions, such as moving loads in and out of acid/alkali baths. The effect is readily identified through the loss of flexibility and roughness to the touch. While light surface rusting is unlikely to affect the rope strength, it may be indicative of internal corrosion, the effect of which is not predictable.

Heat Damage

Heat damage as evidenced by discolouration of the wires, loss of lubrication or pitting of the wires caused by electric arcing.

Documents to be supplied in Accordance with the Relevant Legislation and Standard

- EC Declaration of Conformity (guidance LEEA 030.1e)
- Manufacturers Certificate (guidance EN 13414 -1, 2 and 3)
- Manufacturer's instructions for use (guidance LEEA SI.2.3)

Note: the EC Declaration of Conformity and Manufacturers Certificate can be issued as a single document.

As wire rope slings are frequently used for multi-purpose lifting applications, precise details of the load to be lifted are not always available. In these circumstances, only a general specification can be given but should, as far as possible, include the following information:

- The maximum load to be lifted and, if available, dimensions of the load together with details of any permanently built-in lifting points
- The number of sling legs required and length
- If multi-leg, the range of angles for which the sling is to be rated (i.e. 0-45° or additionally 45°-60°)
- The upper and lower terminal fittings required (if any) or type of eye, e.g. soft eye, thimbles
- Information on any adverse environmental conditions, e.g. exposure to chemical atmospheres, high or low temperatures, exposure to the elements etc.

- The conditions of loading, including whether the sling is likely to be subjected to a shock load, whether the load to be lifted is inherently dangerous, e.g. hot metal or acid, whether the load is to be transported over areas involving high risk e.g. work areas
- The extent of the headroom available if known
- Other technical requirements or any special requirements applicable on the site(s) where the sling is to be used

Training

Operative training should take the manufacturer's instructions for and use into account, paying particular attention to the following:

Due to the multiple applications for which the wire rope slings are used, the operative may frequently be the person who selects the sling. It is therefore recommended in such cases that all applicable information be available to the operative including this Code of Practice and the manufacturer's instructions.

Textile Slings – Fibre Rope and Fibre Rope Slings

Fibre rope slings are the traditional form of textile sling whose origins are recorded in the earliest history of lifting equipment. Although their use has declined in recent years in favour of the newer forms of textile slings, i.e. flat woven webbing slings and roundslings, they may still be found in general use throughout industry.

Fibre rope slings are produced from cut lengths of rope which are then hand spliced. In the case of three strand rope this is an easily learned skill and as a result many fibre rope slings are produced by the user. The intention is not to condemn or condone this practice, but to acknowledge that it occurs. It must be remembered that the manufacturer of the sling is the responsible person (legal) under the Supply of Machinery (Safety) Regulations, who must comply fully with that legislation.

LEEA therefore strongly recommended that slings are obtained from a lifting equipment supplier who is able to guarantee compliance with the appropriate legislation and Standards.

Applicable Standards and References

BS EN 1492-4: 2004 + A1: 2008 – Textile slings - Safety – Lifting slings from natural and man-made fibre ropes, is a harmonised European standard and replaced BS 6668: Part 1.

Traditionally in the UK, fibre rope slings were rated by applying a reduction factor to the minimum breaking load. This reduction factor was derived from a formula which decreased the factor as the rope size increased.

The European Machinery Directive states that, as a general rule, it should be at least 7:1 and BS EN 1492-4 uses the same value.

The fibre rope slings covered by this section of the code may be manufactured from the following natural or man-made fibre ropes only:

- Hemp (natural)
- Sisal (natural)
- Manila (natural)
- Polypropylene (man-made)
- Polyester (man-made)
- Polyamide [Nylon] (man-made)

All other fibre ropes, whether of natural or man-made fibres, are excluded.

Notes:

Defi

Definitions

Three strand hawser laid rope - constructed from three strands of yarns spun from fibres. The strands are twisted together (laid) in right hand lay, this is known as a Z direction of lay.

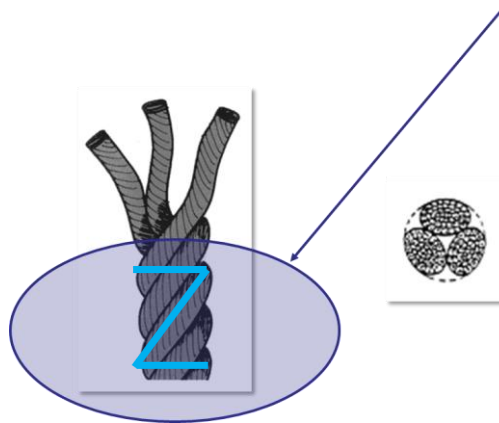

Eight strand plaited rope - constructed from eight strands of yarns spun from fibres. The strands are laid together in pairs, each alternative pair consisting of two left hand (S twist) strands and two right hand (Z twist) strands respectively. The eight strands collectively contain the same number of yarns as the three strand rope of equivalent size. Hence the weights and breaking strengths of both constructions are the same size for size.

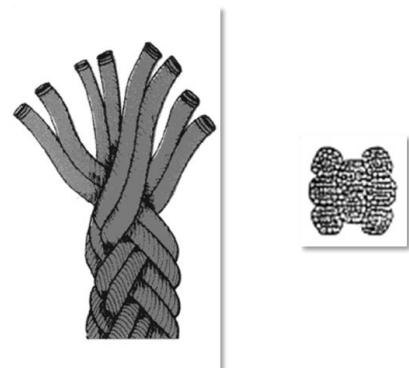

Fibre rope sling

Flexible sling comprising one or more parts of identical fibre rope, terminating in spliced eyes with or without thimbles and fittings, or in the case of an endless sling, joined to itself with a splice.

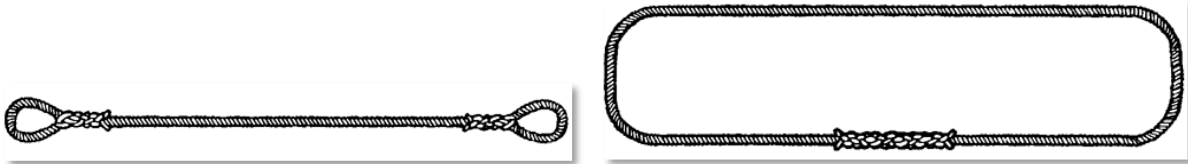

Multi-leg sling

Fibre rope sling assembly, consisting of two, three or four identical legs attached to a master link.



Splice

Specified method of laying the tail end strands of the rope into the strands of the standing part of the rope to form an eye or join the ends of the rope together.

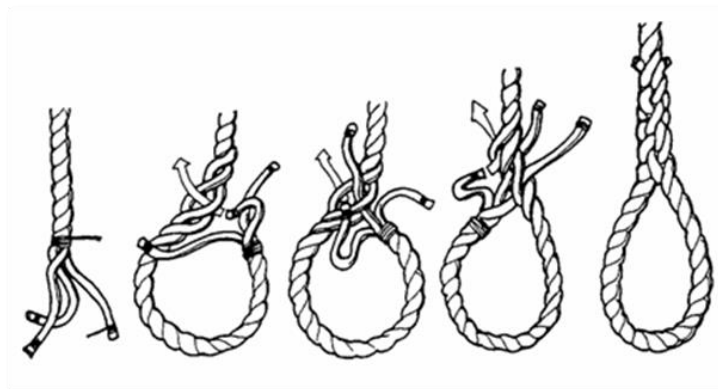

Soft Eye

Eye made by forming the end of the rope into a loop and by splicing the free end to the standing part.



Thimble or Hard Eye

Spliced eye containing a rigid thimble.

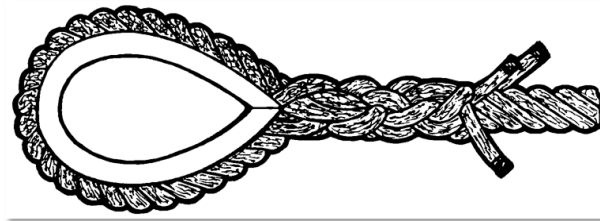

Notes:

Thimble

Rigid, shaped component for insertion into an eye for the purpose of protecting the eye from contact damage, abrasion and deformation.



Fittings

Loadbearing metal components, designed to be fitted and supplied as part of a sling, so as to permit the sling to be attached to other lifting accessories or connected to the load.

Note: Thimbles are not included within the term 'fitting'.

Master link

Link, or link assembly, forming the upper terminal fitting of a multi-leg sling assembly by means of which the sling assembly is attached to the hook of a crane, other lifting machine or accessory.

Nominal diameter

Specified diameter of the rope, which is usually used as the reference value for a given product.

Nominal Length

Specified length of the sling, inclusive of fittings, from bearing point to bearing point.

Effective Working Length (EWL)

Actual finished length of the fibre rope sling, inclusive of fittings, from bearing point to bearing point.

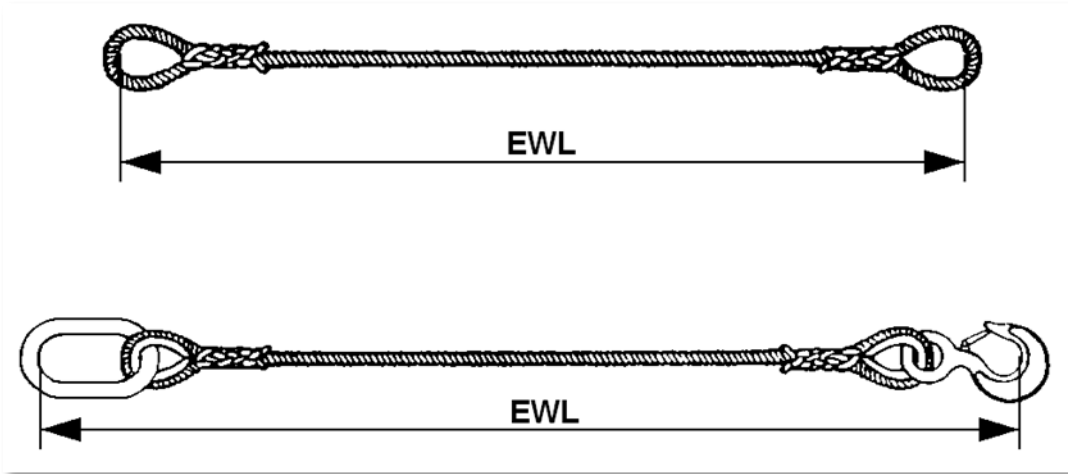

Safety Requirements

Materials

The fibre rope from which the sling is manufactured shall be from one of the materials and to the specification given in the table below:

Type of fibre rope	Specification
Manila (Ma)	EN 698
Hemp (Ha)	EN 1261
Sisal (Si)	EN 698
Polyamide (PA)	EN 696
Polyester (PES)	EN 697
Polypropylene (PP)	EN 699

NOTE: Please be aware of the differing operating temperature ranges and resistances to chemicals as covered in Part 1 Module 13.

Sling Construction

Splicing is the only method to be used for joining or producing eyes.

Endless slings shall have only a single splice.



Other sling legs shall be spliced at each end to produce an eye and no other splices shall be permitted.

Multi-leg slings shall be constructed so that all corresponding items are identical in respect of rope construction, size, material and fittings.

Notes:

Soft eyes

The minimum internal length, of a soft eye measured with a steel tape or rule graduated in increments of 1 mm when closed by hand shall not be less than the appropriate value given in the table below:

Reference number of rope	Min internal length of eye (mm)
16	150
18	155
20	160
24	170
28	185
32	195
36	210
40	220
44	232
48	245

Thimble or Hard Eyes

The thimbles used to form thimble, or hard, eyes shall comply with BS EN 13411-1 and have a corrosion resistant finish.

Note 1: Steel thimbles should not be black finish but should be suitably plated or galvanised to resist corrosion.

Note 2: The use of thimble (hard) eyes is recommended when fittings form part of the fibre rope sling.

Note 3: The fitting of heart shaped thimbles will prevent the sling being used in choke hitch. In such cases, either a soft eye or thimbles of a shape and size suitable for reeving may be used.



Splicing

All splicing shall be carried out by a trained and competent splicer. This splicer shall have sample splices verified by type testing which will be covered later in this module.

Where 3 and 4 strand laid ropes are spliced by short splices, the splice shall comply with the following requirements:

- a) All the tucks of the splice shall be against the lay of the rope
- b) For polyamide, polyester multifilament ropes and polypropylene monofilament ropes, either five full tucks shall be made; alternatively four full tucks with all of the yarns in the strands shall be made, followed by a further tuck with not more than half of the material cut out of each strand and a final tuck with not less than a quarter of the original strand material
- c) For polypropylene fibrillated film and staple ropes and for natural fibre ropes, not less than four full tucks shall be made, each with all of the yarns in the strands
- d) After completion of splicing, the protruding strands, or parts of strands, shall be cut at a distance of not less than one nominal rope diameter from the standing part of rope. As an alternative, for polypropylene fibrillated film and staple fibre ropes and for natural fibre ropes, one fewer full tuck is permissible, in which case the length of the protruding strands after completion of the splicing shall not be less than three times the nominal diameter of the rope.
- e) In the case of endless slings, the splicing requirements given in a) to d) shall apply to each side of the marrying point of the rope.

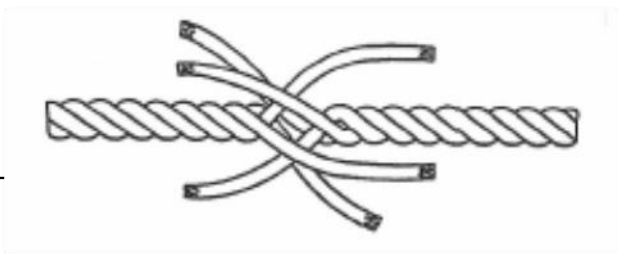

- f) Where the protruding parts of the strands are contained, e.g. by binding, gluing, tapering etc., to improve the appearance of the finished splice, such finishing shall not affect the performance of the splice. In the case of full strands an alternative method of finishing the splice, known as dogging, where the emergent strands are separated into identical proportions and then bound (seized) one half of the emergent strand to the adjacent half of the next emergent strand and so on around the rope is permissible. Tapered splices shall not be subject to dogging.

Alternative Splicing Methods

The method of splicing known as the 'Liverpool splice' where the tucks are made with the lay of the rope shall not be used.

Length between splices

For single leg slings and the individual legs of multi-leg slings, there shall be a minimum length of rope between the emergence of the final tucks of the splice of 20 times the nominal diameter of the rope.

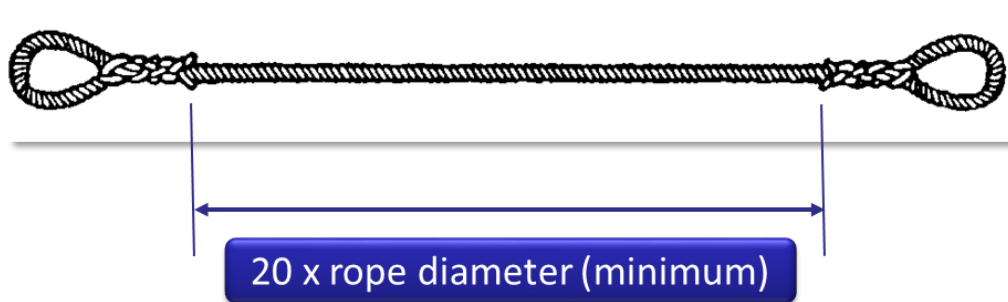

Effective Working Length

The effective working length of a fibre rope sling shall not differ from the nominal length by more than 3%, when laid flat under hand tension and measured with a steel tape or rule graduated in increments of 1 mm.

The length of each leg of a multi-leg sling shall not differ from the lengths of the other legs by more

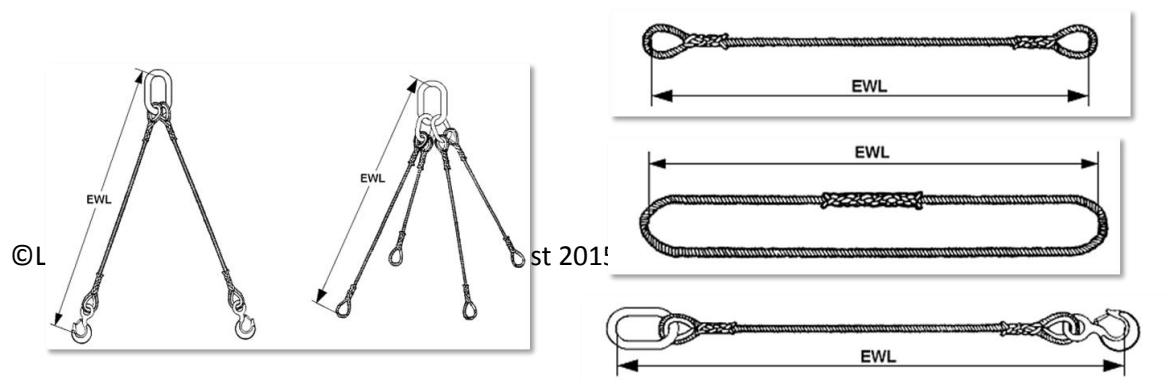

than 2.5%.

Assembly Factor

The assembly factor takes the multiplicity of parts into account to determine the WLL of the sling assembly. For single and endless slings, this assumes the sling to be in a straight pull and for two leg, three leg and four leg slings it assumes the legs will be disposed at a maximum angle of 45° to the vertical.

	Sling Assembly	Factor	WLL of Assembly
	Single	1	1 x WLL of the single part
	Endless	2	2 x WLL of the single part
Notes	2 - Leg	1.4	1.4 x WLL of the single part
	3 and 4 - Leg	2.1	2.1 x WLL of the single part

Mode factors

The geometry of the slinging arrangement, i.e. mode of use, calls for a further factor to be applied to the marked SWL to arrive at the maximum load that may be lifted by the sling in a particular configuration.

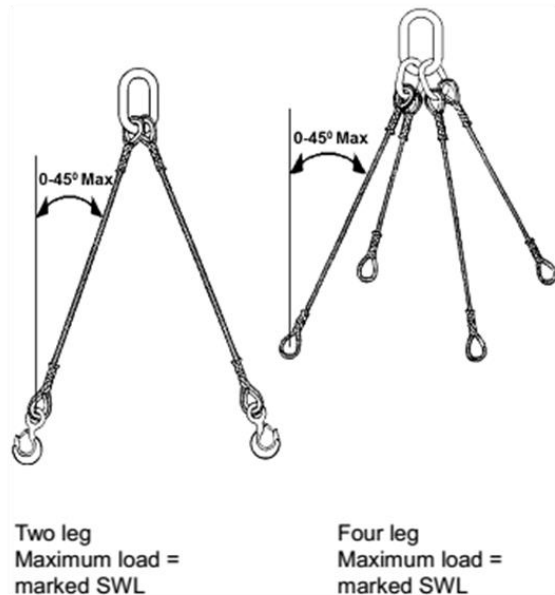
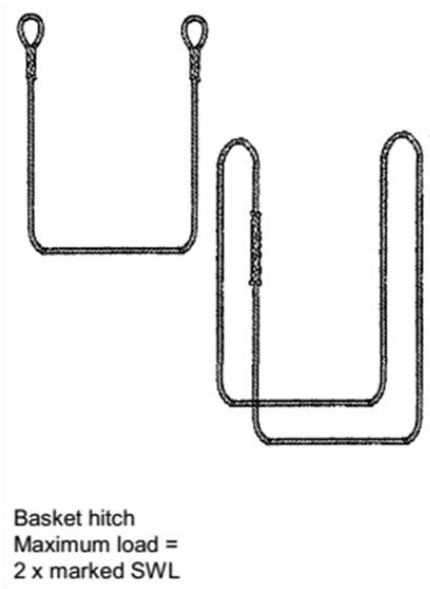
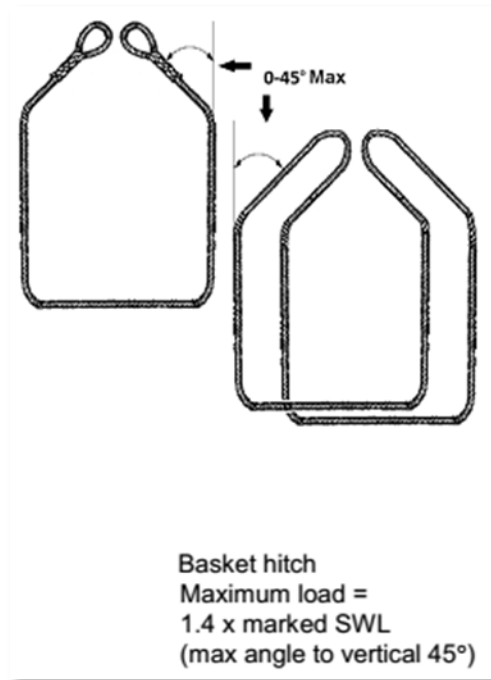
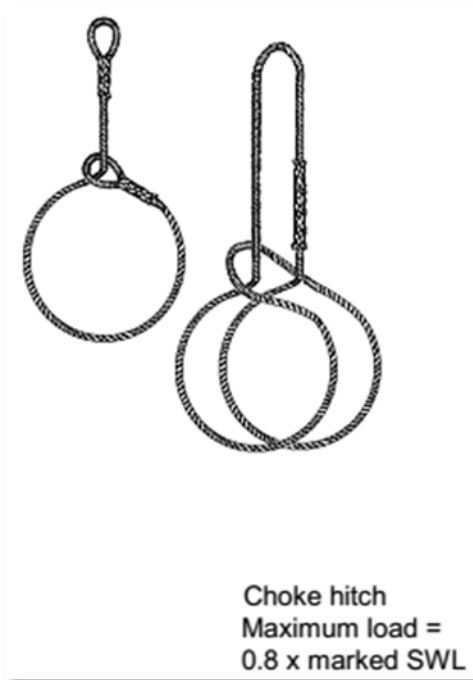

Manufacturers Verification

Visual Examination

Each completed sling or sling assembly shall be visually examined. If any non-compliance with the safety requirements or if any defect is found, the sling shall be rejected.

Marking Requirements

- CE Mark
- Working load limit in straight lift in the case of single leg or endless slings or for multi-legs with an angle of 0 – 45° degrees
- Material of the rope
- Reference number of the rope and grade of fittings
- Nominal length in m
- Business name, symbol, trade mark or other unambiguous identification
- Traceability code
- Number and part of this standard
- Year of manufacture

Labelling

The information specified on the previous slide shall be marked on a label attached to the sling as follows:

- On single legs with soft eyes, in one eye adjoining the splice or on the standing part of rope at the end of the splice
- On single legs with thimbles, on the standing part of rope at the end of the splice
- On multi-leg slings, on a durable label (e.g. a round tag) attached to the master link or on one leg of the sling
- On endless slings, at the end of the splice

Note: One suitable method for applying the marking is to inscribe the details onto a plastic sleeve threaded on the rope and shrunk to it, with a clear plastic sleeve shrunk over the marked sleeve to protect it from soiling.

Manufacturers Certificate

After all testing and examination, the manufacturer shall issue to the purchaser, for each batch of slings delivered, a certificate which shall include at least the following information:

- Manufacturer's name, address, symbol or mark and where applicable the name and address of the authorized representative
- WLL of the sling, and for multi-leg sling assemblies the angle to the vertical
- Type, including eye, fitting, number of legs and nominal length
- Nominal diameter or reference number of rope, the rope material and type of construction
- Grade of fittings
- Number of this European Standard, i.e. EN 1492-4:2004
- Traceability code
- Identity of the person authorized to sign the certificate on behalf of the manufacturer and date of signature
- The static test coefficient(s) used for design of component(s) (e.g. hook, link or shackle)

Information which should be exchanged between the User and the Designer or Supplier

As fibre rope slings are frequently used for multi-purpose lifting applications, precise details of the load to be lifted and mode of use are not always available. In these circumstances, only a general specification can be given but should, as far as possible, include the following information:

- Type of sling required, e.g. single leg, endless
- Type of eye, e.g. soft eyes, or if fittings are required, details of the fittings, e.g. hook
- Gross weight and dimensions of the load to be lifted together with details of any permanently built-in lifting points or the maximum load to be lifted
- Effective working length of the sling
- The mode of use, e.g. whether the sling is to be used in choke hitch, basket hitch etc.
- The environmental conditions, particularly if the temperature is outside the range of - 40°C to 80°C or if there is any exposure to specific chemicals, liquids or gases
- The conditions of loading including:
 - Whether the sling is likely to be subject to shock load

- Whether the load is to be transported over areas involving high risk, e.g. work areas (This should not be done if it can be avoided)
- Whether the load itself is hazardous.
- Material from which the sling is to be manufactured
- If any protective sleeves are required, the length and number of sleeves to be fitted
- Any special instructions including any special marking requirements

Note: In the absence of any specific information, the supplier will assume that the circumstances of use are suitable for the sling to be used at its maximum safe working load and the sling(s) will be marked and certified on that basis.

<p>Notes:</p>

The Thorough Examination

A thorough examination should be carried out at intervals not exceeding six months in accordance with LOLER. This interval should be less where deemed necessary in the light of service conditions.

Assess the extent and severity of soiling. Heavy soiling can obscure damage, making detection difficult. It can also make identification difficult by obscuring any marking or colour coding.

Grit and dirt will pick up on the rope fibres and can cause rapid wear and abrasion.

Where necessary they should be washed in clean water or in accordance with the manufacturer's instructions.

If any of the following defects are found, they should be withdrawn from service and referred to a Competent Person:

- **Wear and chafing:** The filaments and fibres are breaking down. In ordinary use some disarrangement or breaking of the fibres is to be expected. This is harmless if not excessive. It is natural for man-made fibre ropes, especially those of multifilament construction, to raise a pile or fur on their surface as the result of use. This is not cause for concern unless it becomes excessive

- Abrasion: Localised areas of abrasion, as distinct from general wear, are caused by mishandling such as the passage of the sling over a sharp edge whilst under tension
- Mechanical damage: Crushing of the strands, cuts or other forms of mechanical damage
- Fraying: Fraying of the yarns or strands is often an indication of cutting
- Internal wear: Excessive looseness of the strands or the presence of fibre dust within the rope. This is caused by repeated loading and flexing of the rope under tension. It is accelerated by the penetration of grit and particles into the rope
- Mildew: In the case of natural fibre rope slings, the growth of mildew will cause serious loss of strength as the mould will live on the cellulose of the rope. It is caused by dampness, storage of wet slings or storage in stagnant air. In the case of man-made fibre rope slings, mildew will only grow on surface contamination, it does not affect the rope and may be removed by washing in clean water only. Detergents or other cleaning agents must not be used
- Chemical attack: In the case of natural fibre rope slings, any known contact with chemicals or their fumes. In the case of man-made fibre rope slings, selective resistance permits some contact with chemicals however attack by strong solutions or by other chemical contaminants will result in loss of strength. Chemical attack may be recognised by embrittlement and flaking of the fibres or by a softening of the fibres, which may be rubbed or plucked from the rope
- Heat damage: charring of natural fibres, fusing of fibres and glazed appearance of man-made fibres indicate the sling has been subjected to excessive heat, often as the result of friction. This can occur in use, e.g. by careless handling when the sling is used in choke hitch. It is difficult to observe unless severe. Other forms of heat damage, such as burning caused by weld splatter, are more easily identified
- Solar degradation: The outer fibres become brittle as the result of exposure to sunlight or other sources of ultra-violet radiation
- Damaged fittings: Any damage or distortion, e.g. nicks, cracks, twisting or stretching of permanently attached fittings
- Damaged thimbles: Collapsed, cracked, deformed or twisted thimbles

Note: Great care must be taken when inspecting slings as the vulnerability of fibre rope slings to the effects of wear, abrasion and mechanical damage increases inversely with the size of rope. The smaller the rope diameter, the more of the yarns are exposed on the surface, hence the effects of wear and damage are more severe.

Ensure that all fibre sling **markings** are correct and legible as per the requirements of the standard

- Working load limit in straight lift in the case of single leg or endless slings, or for multi-leg slings having an angle of 0° to 45°
- Material of the rope, e.g. manila, polyester etc.
- Reference number of the rope and grade of fittings
- Nominal length in metres (m)
- Manufacturer's name, symbol, trade mark or other unambiguous identification and, where applicable, his authorised representative
- Traceability code
- Number and part of this European Standard
- Mandatory marking (i.e. CE Marking)

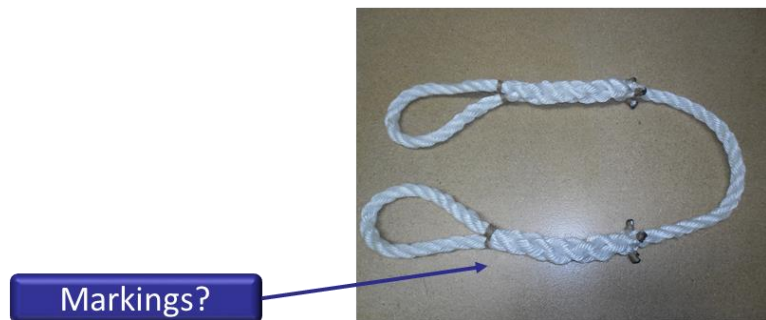

Terminal Fittings

If the fibre rope sling has terminal fittings like master links and hooks fitted, then these should always be examined paying particular attention to:

- Master link twisting or signs of overloading
- Wear up to a maximum of 8%
- Corrosion
- Gouges in the link which can cause cuts to the fibre rope
- Hooks opening up and safety latches not operating correctly
- Hooks twisted
- Hooks corroded

Condition of Splices and Rope

Examine the rope splices and rope body for signs of:

- Splice unravelling or tucks pulling out
- Wear or chafing of the rope
- Localised areas of abrasion, often caused by the sling passing over sharp edges without protection
- Cuts to the rope
- Black spots or signs of mildew on the rope, especially natural fibres as this mildew can seriously affect the strength of the rope
- Signs of chemical attack or heat damage
- Signs of solar degradation, the outer fibres of the rope becoming brittle as the result of exposure to sunlight
- Collapsed, cracked, deformed or twisted thimbles

Thorough Examination Report

Complete the Report/ Certificate of Thorough Examination ensuring that the responsible person is aware of defective equipment.

Training

Operator training should take the manufacturer's instructions into account, paying particular attention to the following:

Operatives should be familiar with the methods of marking fibre rope slings together with the mode factors which vary the safe working load according to the mode of use and assembly, e.g. choke hitch, basket hitch, single or multiple slinging, and fully understand how to apply them

Operatives should be instructed in the correct selection of fibre rope slings for varying applications, e.g. use with chemicals, and the steps to be taken if accidental exposure to chemicals occurs.

Notes:

Textile Webbing Slings

Flat woven webbing slings, also commonly known as belt slings, are used for a variety of lifting purposes. They are a form of textile sling which is soft and easy to handle whilst offering rigidity across their width.

These qualities make them ideal for handling loads which require some support when being lifted as the load is spread across the full width of the webbing, thus avoiding point contact as is the case with chains or ropes. They are therefore less liable to damage finished surfaces than rope, wire rope

or chain slings. However they are less robust and more easily damaged than equivalent capacity wire rope and chain slings.

Applicable Standards and References

BS EN 1492-1: 2000 + A1: 2008 – Textile slings - Safety – Flat woven webbing slings, is a harmonised European standard and replaced British Standard BS 3481: Part 2.

Traditionally, in the UK, textile slings were rated on the basis of a minimum factor of safety of 6:1, however, the European Machinery Directive states that as a general rule it should be at least 7:1.

The British Standard was amended in 1997 to reflect this change. At the same time an amendment was included introducing a colour code system to signify the WLL of the sewn webbing component to align with the European standard now published.

BS EN 1677 – Components for Slings.

LEEA Code of Practice for the Safe Use of Lifting Equipment – Section 16.

Exclusions

This section does not cover special slings or slings used for certain applications, the following are therefore excluded:

- Bag slings or the lifting straps which form part of flexible intermediate bulk containers which are covered by BS EN ISO 21898: 2005 - Specifications for flexible intermediate bulk containers (FIBCs) for non-dangerous goods
- Nets, i.e. consisting of several crossed webbings stitched together, or fibre rope cargo nets which are covered by BS 6756: 1986
- Webbings used for the securing or lashing of cargoes to each other on pallets and platforms or in vehicles which are covered by BS EN 12195-2: 2001 - Load restraint assemblies on road vehicles – Safety - web lashing made from man-made fibres
- Adjustable slings, e.g. with intermediate buckles stitched along the webbing
- Slings consisting of webbing with a nominal width of less than 25mm or more than 450mm, or with a nominal thickness of less than 1.2mm

- Slings made from webbing woven from mono-filament yarns
- Slings of tubular webbing
- Slings formed from strips of cut fabric
- Disposable or 'one trip' slings used for pre-slung cargo and not reused. These were covered by BS 3481: Part 3 which

Definitions

Sewn Webbing Component

The sewn webbing component is that part of the sling comprising woven webbing only including the stitching, i.e. an endless sling, a single sling with soft eyes or a single sling excluding its terminal fittings if any.



Working Load Limit

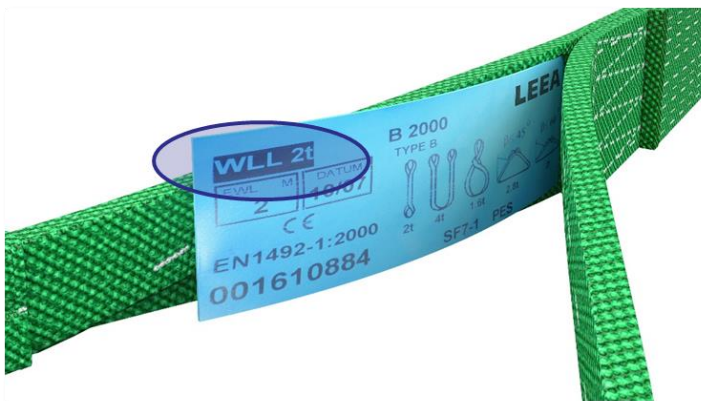

The working load limit marked on the sewn webbing component and indicated by any colour codes or stripe markings is the maximum load that the sewn webbing component may sustain when it is in straight pull.

Note: For use in normal conditions, the SWL of a single leg sling in straight pull, or an endless sling in straight pull, will be equal to the WLL.

Mode Factor

The mode factor is a numerical value which is applied to the marked working load limit of a sewn webbing component to determine the maximum load which the sling may lift according to the mode of use and assembly, e.g. choke hitch, basket hitch, single or multiple slinging.



Protective Sleeve

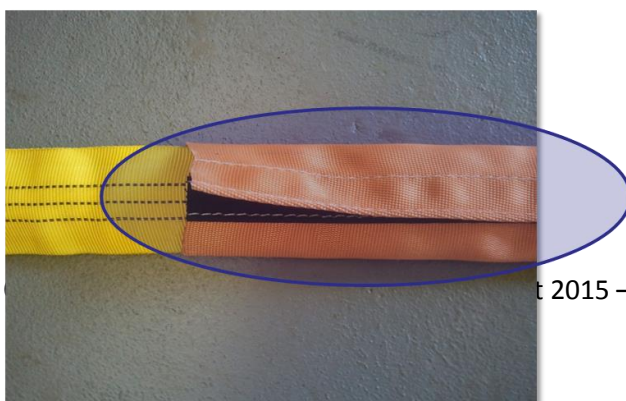

A protective sleeve is a tubular sleeve, either fixed or movable, which may be of leather, woven fabric or other material placed over the webbing to provide extra protection to the webbing. It has no effect on the strength

of the sling. Similar protection may also be given to soft eyes.

Soft Eye

A soft eye may be used to terminate a sling leg. It is formed by folding the webbing back on itself in the form of a loop, the free end of which is then sewn back to the body of the webbing so forming an eye.

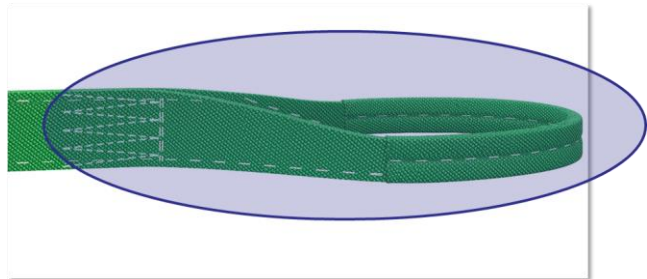

Effective Working Length (EWL)

The actual finished length of the flat woven webbing sling, inclusive of fittings, from bearing point to bearing point.

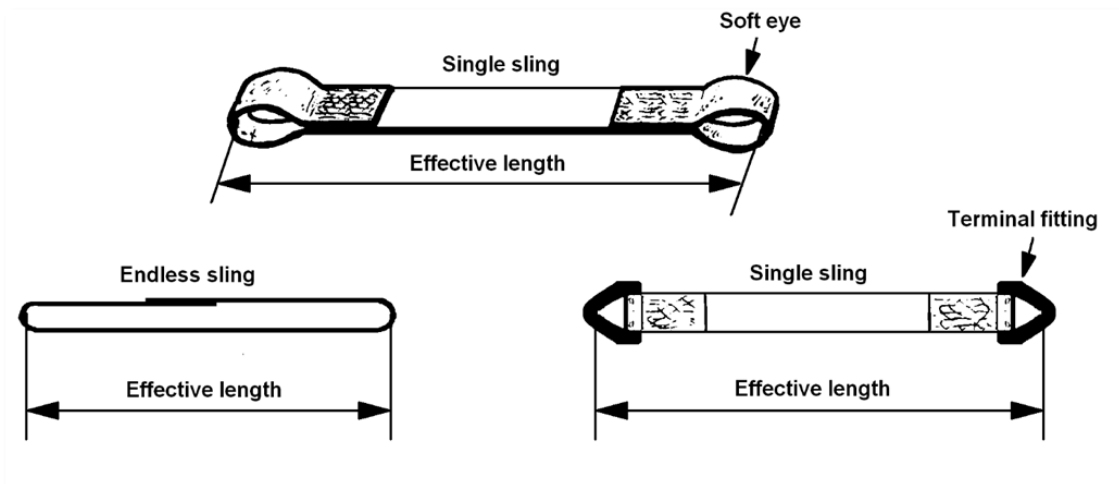

The effective working length (EWL), of a flat woven webbing sling shall not differ from the nominal length by more than 3 % of the nominal length, when laid flat and measured with a steel tape or rule graduated in increments of 1 mm.



Manufacturing

Materials

The webbing shall be woven wholly from industrial yarns and certified by the manufacturer as being fast to light and heat-stabilized from one of the following materials:

- Polyamide (PA) GREEN COLOURED LABEL
- Polyester (PES) BLUE COLOURED LABEL
- Polypropylene (PP) BROWN COLOURED LABEL

Note: attention is drawn to the different resistance of man-made fibres to chemicals, which were explained in the Part 1 Entrance Certificate course.

Your studies and experience may mean that you have only experienced webbing slings made from Polyester as these are by far the most common.

136

Width

The width of the woven webbing, shall not be less than 25 mm and shall not exceed 450 mm and when measured with a steel tape or rule graduated in increments of 1 mm, shall have the following tolerances:

- $\pm 10\%$ for nominal widths less than or equal to 100 mm
- $\pm 8\%$ for nominal widths greater than 100 mm

Webbing Thickness and Sling Thickness

For single layer flat woven webbing slings, the load bearing element of the sling shall have a minimum thickness of 2 mm. For multi-layer slings, the webbing used to provide each layer of the loadbearing element of the sling shall have a minimum thickness of 1.2 mm.

Sewing of Slings

All seams shall be made from thread of identical parent material as the webbing (so all properties are the same) and shall be made with a locking stitch machine. Stitches shall not touch or affect the edges of the webbing except those which secure the eye durability reinforcement.

Note: The use of a different colour thread to that of the rest of the sling will facilitate inspection during the manufacturer's verification and in-service inspections by the user.

The lockstitch uses two threads, an upper and a lower. Lockstitch is so named because the two threads, upper and lower, "lock" together in the hole in the fabric which they pass through, as shown in the picture below:

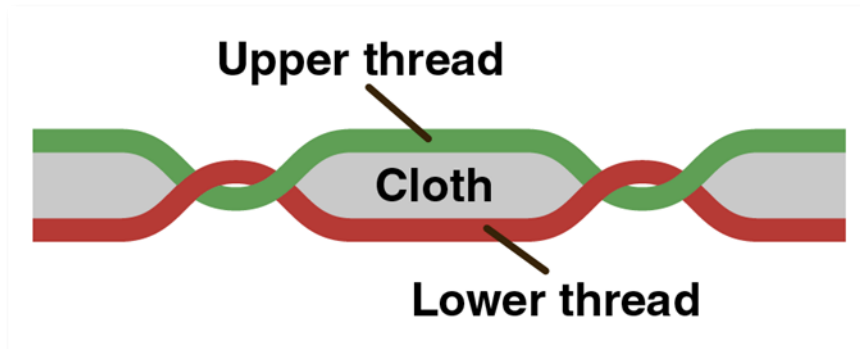

The stitches of the seam traverse (run across) the parts of the webbing to be sewn together, and the stitching must lay flat and not have loops above the surface of the webbing.

The ends of cut webbing shall be treated in such a way (e.g. fused by heating) as to prevent unravelling. Treatment of cut ends by heating shall not damage adjacent stitching, and heat-treated ends shall not be over sewn.

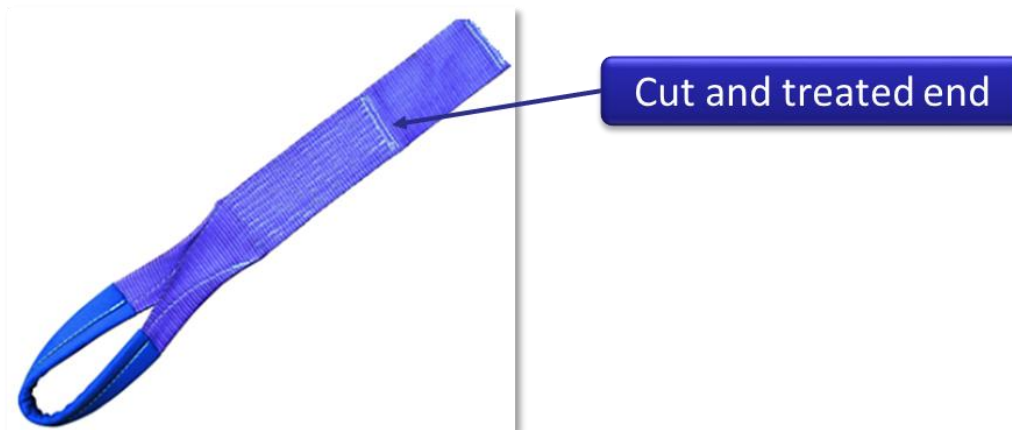

Note: Where the webbing has been impregnated to prevent thread slippage, further treatment is not necessary, in which case the ends may be over sewn.

Soft Eyes

The inside length of the eyes, when measured flat using a steel tape or rule graduated in increments of 1 mm, shall be of the following minimum dimensions:

- Three times the width of the webbing for width of up to 150 mm

- Two and a half times the width of the webbing for widths greater than 150 mm

Preferred Types of Eyes

The standard specifies types of preferred eye but also states that the list it provides is not exhaustive; other variations may be used. The illustrations below show some of the listed eye formations:

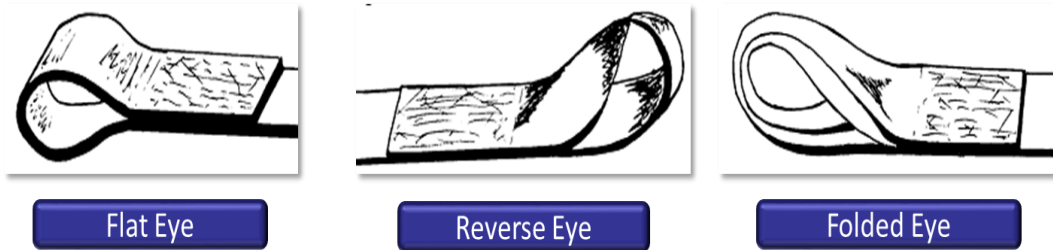

Reinforcement of Soft Eyes

Soft eyes shall be reinforced to protect the inner surface of the eye against damage during lifting and at the point of choking in a choked lift.

Note: examples of suitable reinforcing material are a sleeve or piece of webbing or leather or other durable material.

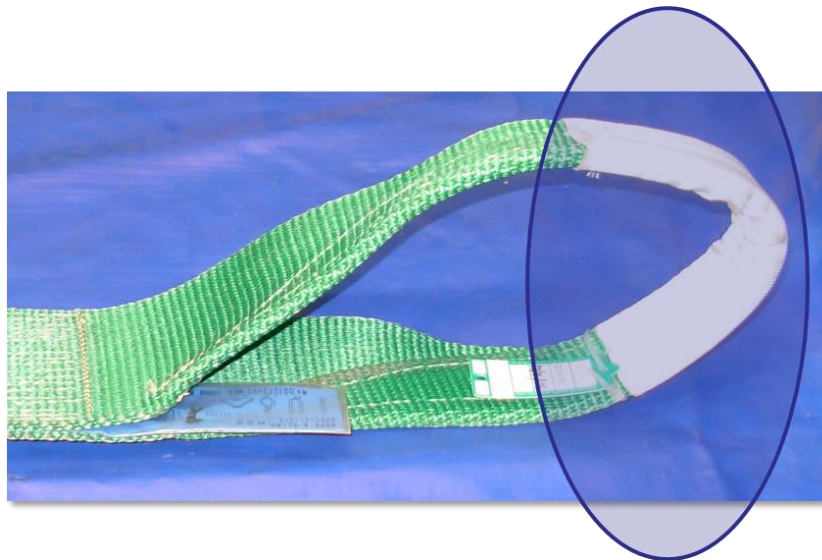

Colour Coding

Flat woven webbing slings and roundslings are colour coded to signify the WLL of the 'sewn webbing component' in straight

©LEEA Academy – LEG – Step Notes

SLING COLOUR	WLL
Violet	1.0t
Green	2.0t
Yellow	3.0t
Grey	4.0t
Red	5.0t
Brown	6.0t
Blue	8.0t
Orange	10.0t
Orange	Above 10.0t

pull. This must not be confused with the WLL of the completed sling assembly, which may be different. The marking information must always be read to establish the WLL of the sling assembly.

Safety Requirements

Failure Force

The minimum failure force for the sewn webbing component shall be such that it will sustain a force equivalent to 7 times the WLL when tested in accordance with annex A of the standard. It shall not be pre-loaded prior to testing, unless all sewn webbing components of the same type are subjected to identical pre-loading.

Fittings Supplied as Part of a Sling

Fittings shall conform to the appropriate part or parts of BS EN 1677.



The seating of a fitting in contact with the webbing shall be so finished that, when tested in accordance with the requirements of this BS EN 1492-1:

- There shall be no damage to the area of webbing in contact with the fitting
- The sling shall sustain the load

Welded fittings shall be placed so that the welds remain visible when the sling is in use.

Reinforcements and Protection against Damage from Edges and/or Abrasion

Durability reinforcement, where provided, shall be cast onto the webbing, or in the form of a piece of reinforcing material or sleeve which shall be sown to the webbing.

Protective sleeves, where provided, shall be of tubular



form such that they are free to enable them to be positioned over the part of the sewn webbing component which is to be protected. Examples of suitable reinforcing and protection materials are webbing, woven fabric, leather or other durable material.

Traceability Code

The traceability code, which is to be included in the marking, shall enable at least the following basic elements of the manufacturing record to be traced:

- Identification of webbing
- Identification of manufacturer's control
- Identification and grade of fittings

Manufacturers Verification

All testing and examination shall be carried out by a competent person.

Type Tests

The first representative sling of each type or construction, including change of material, shall be tested to verify the WLL.

If, during testing, the sewn webbing component does not sustain a force equivalent to seven times the WLL, but sustains a load of not less than 90% of this force, three further samples of the same type shall be tested. If one or more of these samples does not sustain a force equivalent to seven times the WLL, slings of this type shall be deemed not to comply with this standard.

Notes:

Manufacturing Testing

Manufacturing test when a quality system conforming to ISO 9002 is in place:

If a quality system conforming to EN ISO 9002 is in place, during the manufacture, slings shall be selected for testing at least at the intervals given in the table below or every 2 years, whichever is the sooner:

WLL Of Webbing	Maximum quantity between type tests
Up to and including 3t	1000
Over 3t	500

If, during testing, the sewn webbing component does not sustain a force equivalent to seven times the WLL, but sustains a load of not less than 90 % of this force, three further samples shall be tested. If one or more of these samples does not sustain a force equivalent to seven times the WLL, slings of this type shall be deemed not to comply with this BS EN 1492-1.

Manufacturing test when a quality system conforming to EN ISO 9002 is not in place:

If a quality system conforming to EN ISO 9002 is not in place, during the manufacture, slings shall be selected for testing at least at the intervals given in the table below or every 12 months, whichever is the sooner:

WLL Of Webbing	Maximum quantity between type tests
Up to and including 3t	500
Over 3t	250

If, during testing, the sewn webbing component does not sustain a force equivalent to seven times the WLL, but sustains a load of not less than 90% of this force, three further samples shall be tested. If one or more of these samples does not sustain a force equivalent to seven times the WLL, slings of this type shall be deemed not to comply with this BS EN 1492-1.

Notes:

Visual and Manual Examination

Each completed sling or sling assembly shall be visually and manually examined during the manufacturing stage, including measurement of the principal dimensions. If any non-compliance with the safety requirements or if any defect is found, the sling shall be rejected.

Test and Examination Records

The manufacturer shall retain a record of the results of all tests and examinations for inspection and reference purposes.

Manufacturers Documentation

Documents to be supplied in accordance with the relevant legislation and relevant standard:

- EC Declaration of Conformity (guidance LEEA 030.1e)
- Manufacturers Certificate (guidance BS EN 1492-1 clause 8)
- Manufacturer's instructions for use (guidance LEEA SI.3.4 and BS EN 1492-1 annex B)

Note: the EC Declaration of Conformity and Manufacturers Certificate can be issued as a single document.

Manufacturers Certificate

The certificate shall include at least the following information:

- The manufacturers name and address, symbol or mark
- Working load limit for the sling and for multi-leg sling assemblies the range of angles to the vertical
- Type, including eye, fitting, number of legs, nominal length and width
- The expression 'flat woven webbing sling' or 'flat woven sling assembly'
- Material of the webbing
- Grade of fitting
- If fitted details of the reinforcements & protection against damage from edges and or abrasion
- The number of the European standard, e.g. EN 1492-1
- Test references, refer to clause 6 of EN 1492-1
- Traceability code
- Identification of the person authorised to sign the certificate on behalf of the manufacturer and date of the signature

Markings Required

- CE Mark
- Working load limit, in straight lift
- Material of the webbing
- Grade of fitting(s) if any fitted
- Nominal length in metres (m)
- Business name of the manufacturer or symbol, trade mark or other unambiguous Identification

- Traceability code
- A reference to the standard to which it was made
- Year of manufacture

Additional marking requirements for multi-leg slings (to be marked on a round tag attached to the master link)

- Maximum angle of use of any leg to the vertical
- Label on each leg must not show the WLL

Marking

The marking may be directly onto the sling or on a sewn-on label. This marking must be such that it will not affect the safety of the sling when in use. For slings to BS EN 1492-1, the material of the webbing will be identified by the colour of the label: for polyamide (nylon) this will be green, for polyester blue and for polypropylene brown. Slings to the older standard may be similarly marked. Terminal fittings should be individually marked to identify them with the appropriate record. For webbing slings this label has to be sewn into the eye or joining stitching of webbing slings.

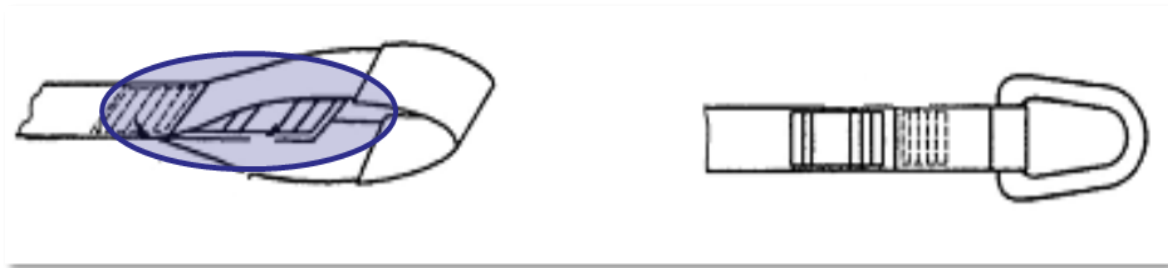

Check that the sling markings correspond with previous Reports of Thorough Examination (ROTE) and the Manufacturer's Declaration of Conformity (DOC).

ALL markings need to be clear and legible.

Warning

Slings to BS EN 1492-1 and the latest version of BS 3481: Part 2 are dyed with a colour code to indicate the working load limit of the sewn webbing component. The WLL may also be indicated by stripes or lines running along the length of the sling;

i.e. 1 stripe = 1 tonne, 2 stripes = 2 tonnes etc.

These colours and markings relate to the WLL of the sewn webbing component only and older slings may be marked with alternative colours or no specific colouring. For these reasons and due to the fact that a large proportion of the working population are colour blind to some degree, the user should always check the label to confirm the WLL of the sling.

Safe Use of Textile Webbing Slings

Use of flat woven webbing slings in adverse conditions or hazardous applications:

The material from which flat webbing slings are manufactured have selective resistance to chemicals.

Solutions of acids or alkalis which are harmless can become sufficiently concentrated by evaporation to cause damage. Contaminated slings should be taken out of service at once, soaked in cold water, dried naturally and referred to a competent person for examination.

Note: Slings with grade 8 fittings and multi-leg slings with grade 8 master links should not be used in acidic conditions. Contact with acids or acidic fumes causes hydrogen embrittlement to grade 8 materials.

If exposure to chemicals is likely, the manufacturer or supplier should be consulted.

Temperature Ranges

Flat woven webbing slings manufactured from polypropylene are suitable for use in the temperature range -40°C to 80°C whilst those produced from polyester or polyamide (nylon) are suitable for the range -40°C to 100°C . These temperatures may vary in a chemical environment and should be checked by reference to the supplier. Under no circumstances should webbing slings be used at temperatures outside of the range advised by the manufacturer.



Care must be taken when selecting slings for use at low temperatures. Although the qualities of the materials used for flat woven webbing slings makes them suitable for use at temperatures as low as -40°C , if moisture is present, ice will be formed. Ice will both act as an abrasive and cutting agent and will damage the sling. Slings selected for use at low temperatures should be dry and steps must be taken to prevent ice forming on or, more importantly, between the woven strands of the webbing.

Chemicals



If the webbing sling is for use in a chemical environment, consult the supplier for advice. Man-made fibres offer a high resistance to chemicals and can, subject to correct material selection, be used in certain chemical environments without detriment.

- Polyester is resistant to moderate strength acids but is damaged by alkalis.
- Polyamide (nylon) is virtually immune to the effect of alkalis but is attacked by moderate strength acids. Attention is also drawn to its loss of strength on wetting which can be in the order of 15%.

- Polypropylene is little affected by either acids or alkalis but is damaged by some solvents, tars, paints etc. It is suitable for applications where the highest resistance to chemicals, other than solvents, is required.
- Consideration must be given to the suitability of the material from which terminal and connecting fittings are made. Certain grades of steel are susceptible to hydrogen embrittlement as the result of contact with acids. This matter is dealt with in HSE guidance note PM39 'Hydrogen Embrittlement of Grade T Chain'. Other metals may be subject to corrosion. The advice of the supplier should always be sought when selecting flat woven webbing slings and/or fittings for use in chemical environments.

In-Service Inspection

In addition to the thorough examination necessary under statutory provisions, all webbing slings should be visually inspected by a Responsible Person prior to use or on a regular basis. The interval between inspections will depend on the conditions of service but as flat woven webbing slings are easily damaged in use, they should be visually checked on each occasion prior to slinging the load. If any of the following defects are found, the sling should be withdrawn from service and referred to a Competent Person:

- Surface chafe. In normal use some chafing will occur and is unavoidable. If this is confined to the surface fibres as opposed to the yarns, it has no effect on the safe use. However in extreme cases, the faces of the webbing become so worn that the outer yarns are severed
- Local abrasion. If the webbing shows signs of local abrasion, as opposed to general wear, serious loss of strength may occur
- Cuts. Both longitudinal and cross cuts into the surface of the webbing result in loss of strength
- Cuts and chafing to the selvedge. A small cut into the selvedge of the webbing will result in serious loss of strength
- Chemical attack. Whilst man-made fibres have a good resistance to selected chemicals, attack by other chemicals to the webbing fibres results in local weakening and softening of the material. This is indicated by flaking of the surface fibres, which can be plucked or rubbed off
- Heat and friction damage. The surface fibres take on a glazed appearance and in extreme cases, fusion of the fibres occurs
- Weld splatter burns. Textile slings are often used in welding processes as they insulate the work piece from the lifting appliance. Weld splatter will cause localised burning and will embed in the webbing, causing internal abrasion
- Damaged stitching. Any damage to the stitching or looseness of the threads noticed at any time must be treated very seriously

- Loose webbing. The webbing becomes loose and soft to the touch so that the weft can be moved or split with the fingers
- Damaged eyes or terminal fittings. Cuts, abrasion or any apparent damage to the stitching around folded eyes and where eye protection is fitted, check this for deep cuts or excessive wear. Cracks, bruising, deformation or any other form of damage to metal terminal fittings. Particular attention should be paid to the webbing where it passes around terminal fittings as this is a point of high wear and cutting can occur from misuse
- Missing or illegible marking
- Soiling. Heavy soiling can obscure damage, making detection during inspection difficult. It can also make identification difficult by obscuring any marking or colour coding. Grit and dirt will pick up on the face of soiled webbing and can cause rapid wear and abrasion. Clean the sling in an approved manner but if the soiling is such that cleaning has little or no effect, withdraw from service and refer to a Competent Person

Note:

Only use cleaning agents approved by the manufacturer, whose instructions on its use must be sought and followed. Clean water may however be freely used.

Notes:

Thorough Examination

A thorough examination should be carried out at intervals not exceeding six months in accordance with LOLER.

This interval should be less where deemed necessary in the light of service conditions.

Assess the extent and severity of soiling. Heavy soiling can obscure damage, making detection difficult. It can also make identification difficult by obscuring any marking or colour coding. Grit and dirt will pick up on the textile fibres and can cause rapid wear and abrasion. Where necessary they should be washed in clean water or in accordance with the manufacturer's instructions.



If the textile webbing sling has terminal fittings like master links and hooks fitted, then these should always be examined paying particular attention to:

- Master link twisting or signs of overloading
- Wear up to a maximum of 8%
- Corrosion
- Gouges in the link which can cause cuts to the fibre rope
- Hooks opening up and safety latches not operating correctly
- Hooks twisted
- Hooks corroded

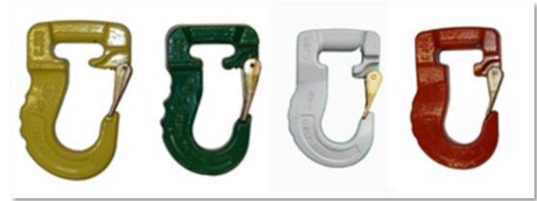

Examine the textile fibres for signs of chafing and localised abrasion.

Examine the textile for cuts paying particular attention to the edges of the sling as even a small nick in the edge of the webbing can seriously weaken the strength of the sling.

Examine the textile for signs of chemical attack which may be indicated by the flaking of the surface fibres which will then be able to be picked or rubbed off.

Examine the textile for signs of heat and friction damage, this can be seen by the surface taking on a glazed appearance and signs of the fibres fusing together.

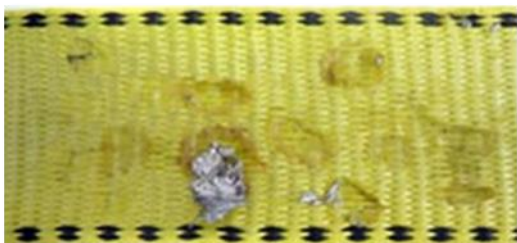

Examine the textile for weld splatter, as textile slings are often used in welding processes as they insulate the work piece from the lifting appliance.

Examine the textile for damaged stitching or looseness of the threads.

Examine the eyes and the eye protection paying particular attention to the point where the eye passes around other lifting accessories or fittings as this is likely to be the point of highest wear.



Training

Operator training should take the manufacturer's instructions into account, paying particular attention to the following:

- Operatives should be familiar the methods of marking webbing slings together with the mode factors which vary the safe working load according to the mode of use and assembly, e.g. choke hitch, basket hitch, single or multiple slinging, and fully understand how to apply them
- Operatives should be instructed in the correct selection of slings for varying applications, e.g. use with chemicals, and the steps to be taken if accidental exposure to chemicals occurs
- Operatives should be instructed in the meaning of colour codes, which denote the WLL of the sewn webbing component and the material from which the sling is constructed. Caution must be exercised, not only as some manufacturers may adopt alternative colour codes, but also as the operative may suffer colour blindness

Notes:

Roundslings

Man-made fibre roundslings are a form of endless textile sling which is soft and pliable to use, easy to handle and especially useful on delicate surfaces. They are however less robust and more liable to damage than equivalent capacity wire rope and chain slings.

Applicable Standards and References

BS EN 1492-2: 2000 + A1: 2008 - Textile slings – Safety – Roundslings, made of man-made fibres, for general purpose use, is a Harmonised European Standard and replaced British Standard 6668: Part 2.

Traditionally in the UK textile slings were rated on the basis of a minimum factor of safety of 6:1, however, the European Machinery Directive states that, as a general rule, it should be at least 7:1.

The British Standard was therefore amended in 1997 to reflect this change. At the same time the colour code system specified in the standard to signify the WLL was amended to align with the European standard now published.

Definitions

An endless flexible sling consisting of a loadbearing core of yarn, completely enclosed in a woven cover, with or without fittings.

Multi-Leg Sling Assembly

Roundsling assembly, consisting of two, three or four identical roundslings attached to a master link.



Notes:



Core

A hank of yarn which comprises the loadbearing part of a roundsling.



Cover

A woven tubular webbing, or tube made from woven fabric and joined along its length, and which encloses the core.



Fitting



A loadbearing metal component, supplied as part of a roundsling so as to allow it to be attached to other lifting accessories, connected to other roundslings to form a multi-leg sling assembly or connected to the hook of a crane or other lifting machine.

Note: Where fittings are used, it may be found that these fittings have a lesser factor of safety than the 7:1 required by BS EN 1492-2, therefore it is important that fittings and roundslings are matched upon the basis of their WLL and not the factors of safety.

Notes:	SLING COLOUR		WLL
	Violet		1.0t
	Green		2.0t
	Yellow		3.0t
	Grey		4.0t
Colour Coding	Red		5.0t
Roundslings are colour coded to signify the WLL of the 'sewn webbing component' in straight pull. This must not be confused	Brown		6.0t
	Blue		8.0t
	Orange		10.0t
	Orange		Above 10.0t

with the WLL of the completed sling assembly, which may be different. The marking information must always be read to establish the WLL of the sling assembly.

Materials

The roundsling shall be woven wholly from industrial yarns and certified by the manufacturer as being fast to light and heat-stabilized from one of the following materials:

- **Polyamide (PA)** **GREEN COLOURED LABEL**
- **Polyester (PES)** **BLUE COLOURED LABEL**
- **Polypropylene (PP)** **BROWN COLOURED LABEL**

Your studies and experience may mean that you have only experienced roundslings made from Polyester as these are by far the most common.

Core

The core shall be formed from one or more yarns of identical parent material wound together with a minimum of 11 turns, and joined to form an endless hank. It shall be uniformly wound to ensure even distribution of the load. Any additional joins in the yarns shall be separated by at least four turns of the yarn and shall be compensated for by an extra turn per join.

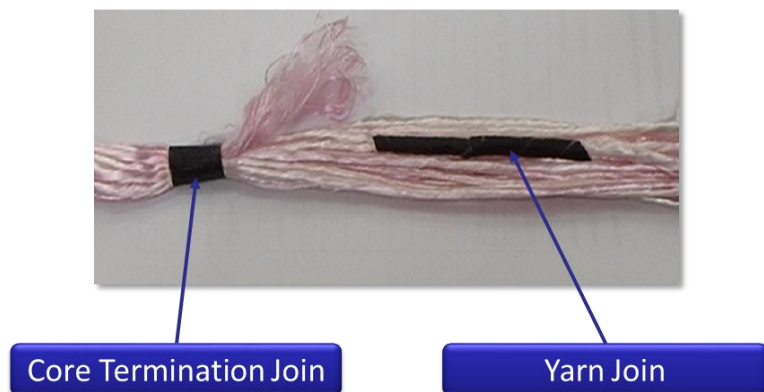

Cover

The cover shall be of webbing woven from identical parent material as the core, and made with the ends overlapped and sewn. The edges of the woven cover material shall be finished in such a way that they cannot unravel. If the cover is welded, care shall be taken to ensure that the welding does not affect the core.

The woven material of the cover shall be treated to produce a closed surface.

Note: These treatments inhibit abrasion and the ingress of abrasive materials and may be applied to the woven material and/or the yarn.

Sewing of slings

All seams shall be made from thread of identical parent material as the cover and the core (so all properties are the same) and shall be made with a locking stitch machine.



Note: The use of a different colour thread to that of the cover will facilitate inspection during the manufacturer's verification and in-service inspections by the user.

The lockstitch uses two threads, an upper and a lower. Lockstitch is so named because the two threads, upper and lower, "lock" together in the hole in the fabric which they pass through.

Safety Requirements

Failure Force

The minimum failure force for the roundsling core in straight pull shall be such that it will sustain a force equivalent to 7 times the WLL when the sling is tested, but during the test the cover shall not rupture at a force equivalent to less than 2 times the WLL. The roundsling shall not be preloaded prior to testing, unless all roundslings of the same type are subjected to identical pre-loading.

Protection against damage from edges and/or abrasion:

Protective sleeves, where provided, shall be of tubular form such that they are free to enable them to be positioned over the roundsling which is to be protected.

Note: Examples of suitable reinforcing and protection materials are webbing, woven fabric, leather or other durable material.

Traceability Code

The traceability code, which is to be included in the marking, shall enable at least the following basic elements of the manufacturing record to be traced:

- Identification of webbing
- Identification of manufacturer's control
- Identification and grade of fittings

Manufacturers Verification

All testing and examination shall be carried out by a competent person.

Type tests

The first representative sling of each type or construction, including change of material, shall be tested to verify the WLL.

If, during testing, the roundsling does not sustain a force equivalent to seven times the WLL, but sustains a load of not less than 90% of this force, three further samples of the same type shall be tested. If one or more of these samples does not sustain a force equivalent to seven times the WLL, slings of this type shall be deemed not to comply with BS EN 1492-2.



Slings designed to be used with Fittings



The first representative roundsling of each type or construction with integral fittings shall be tested to verify the interaction of the roundsling with those fittings.

If, during testing, the cover of the roundsling fails to sustain a force equivalent to two times the WLL of the roundsling, but sustains a load of not less than 90% of this force, three further samples of the same type shall be tested.

If the cover of one or more of these samples does not sustain a force equivalent to two times the WLL, slings of this type shall be deemed not to comply with BS EN 1492-2.

Manufacturing Testing

Manufacturing test when quality system conforming to ISO 9002 is in place:

If a quality system conforming to EN ISO 9002 is in place, during the manufacture, slings shall be selected for testing at least at the intervals given in the table below or every 2 years, whichever is the sooner:

WLL Of Webbing	Maximum quantity between type tests
Up to and including 3t	1000
Over 3t	500

If, during testing, the roundsling does not sustain a force equivalent to seven times the WLL, but sustains a load of not less than 90 % of this force, three further samples shall be tested. If one or more of these samples does not sustain a force equivalent to seven times the WLL, slings of this type shall be deemed not to comply with BS EN 1492-2.

Manufacturing test when quality system conforming to EN ISO 9002 is not in place:

If a quality system conforming to EN ISO 9002 is not in place, during the manufacture, slings shall be selected for testing at least at the intervals given in the table below or every 12 months, whichever is the sooner:

WLL Of Webbing	Maximum quantity between type tests
Up to and including 3t	500
Over 3t	250

If, during testing, the roundsling does not sustain a force equivalent to seven times the WLL, but sustains a load of not less than 90% of this force, three further samples shall be tested. If one or more of these samples does not sustain a force equivalent to seven times the WLL, slings of this type shall be deemed not to comply with BS EN 1492-2.

Notes:

Manufacturers Verification

Visual and manual examination

Each completed roundsling or sling assembly shall be visually and manually examined including measurement of the principal dimensions. If any non-compliance with the safety requirements or if any defect is found, the sling shall be rejected.

Test and examination records

The manufacturer shall retain a record of the results of all tests and examinations for inspection and reference purposes.

Manufacturers Documentation

Documents to be supplied in accordance with the relevant legislation and relevant standard:

- EC Declaration of Conformity (guidance LEEA 030.1e)
- Manufacturers Certificate (guidance BS EN 1492-2)
- Manufacturer's instructions for use. (guidance LEEA SI.4.4 and BS EN 1492-2 annex B)

Note: the EC Declaration of Conformity & Manufacturers Certificate can be issued as a single document.

Manufacturer's certificate

The certificate shall include at least the following information:

- The manufacturer's name and address, symbol or mark and, where applicable, the name and address of the authorized representative
- WLL of the sling, and for multi-leg sling assemblies, the range of angles to the vertical
- Type, including fitting, number of legs and nominal length
- The expression 'roundsling' or 'roundsling assembly'
- Material of the roundsling
- Grade of fitting
- If fitted, details of protective sleeves
- The number of the European Standard, i.e. EN 1492-2
- Test references (see clause 6 of EN 1492-2)
- Traceability code
- Identity of the person authorized to sign the certificate on behalf of the manufacturer and date of signature
- The static test coefficient(s) used for design of component(s) (e.g. hook; link; shackle)

Marking Required

Marking should be directly onto the outer cover or on a label attached to the outer cover of the roundsling. This marking must be such that it will not affect the safety of the sling when in use. For slings to BS EN 1492-2, the material from which the sling is constructed will be identified by the colour of the label: for polyester slings this will be blue, for polyamide (nylon) green and polypropylene brown.

Integral fittings and coupling components should be individually marked to identify them with the appropriate record.

The markings on the label should indicate the following minimum information:

- Safe working load in straight pull or for the appropriate range of angles in the case of multi-leg slings
- Distinguishing mark(s)
- Nominal length
- Material of the roundsling
- Manufacturer's name or identification

Marking for multi-leg sling assemblies

The following requirements shall apply to 2 leg, 3 leg or 4 leg sling assemblies:

The marking shall be on a readily-identifiable form of durable label (e.g. a round shaped tag) which shall be attached to the master link to differentiate from other sling types

The marking of the sling shall include the maximum angle of use of any leg to the vertical

The label on each leg shall not show the WLL

Warning

The covers of slings to BS EN 1492-2 and the latest version of BS 6668: Part 2 are dyed with a colour code to indicate the working load limit of the roundsling in straight pull. The WLL may also be indicated by stripes or lines running along the length of the sling;

i.e. 1 stripe = 1 tonne, 2 stripes = 2 tonnes and so on.

Older slings may be marked with alternative colours or no specific colouring. For these reasons and due to the fact that a large proportion of the working population are colour blind to some degree, the user should always check the label to confirm the WLL of the sling.

Safe Use of Roundslings

Use of roundslings in adverse conditions or hazardous applications:

The material from which roundslings are manufactured have selective resistance to chemicals.

Solutions of acids or alkalis which are harmless can become sufficiently concentrated by evaporation to cause damage. Contaminated slings should be taken out of service at once, soaked in cold water, dried naturally and referred to a competent person for examination.

Note: Slings with grade 8 fittings and multi-leg slings with grade 8 master links should not be used in acidic conditions. Contact with acids or acidic fumes causes hydrogen embrittlement to grade 8 materials.

If exposure to chemicals is likely, the manufacturer or supplier should be consulted.

Temperature ranges



Roundslings manufactured from polypropylene are suitable for use in temperatures from -40°C to 80°C whilst those produced from polyester or polyamide are suitable for the range -40°C to 100°C.

These temperatures may vary in a chemical environment and should be checked by reference to the supplier. Under no circumstances should roundslings be used at temperatures outside of the range advised by the manufacturer.

Care must be taken when selecting slings for use at low temperatures. Although the qualities of the materials used for roundslings makes them suitable for use at temperatures as low as -40°C, if moisture is present, ice will be formed. Ice will both act as an abrasive and cutting agent and will damage the sling. Slings selected for use at low temperatures should be dry and steps taken to prevent ice forming on, or more importantly, between the strands of the sling core or cover.

Notes:

Chemicals



If the roundsling is for use in a chemical environment, consult the supplier for advice. Man-made fibres offer a high resistance to chemicals and can, subject to correct material selection, be used in certain chemical environments without detriment.

- Polyester is resistant to moderate strength acids but is damaged by alkalis

- Polyamide (nylon) is virtually immune to the effect of alkalis but is attacked by moderate strength acids. Attention is also drawn to its loss of strength on wetting which can be in the order of 15%
- Polypropylene is little affected by either acids or alkalis but is damaged by some solvents, tars, paints etc. It is suitable for applications where the highest resistance to chemicals, other than solvents, is required
- Consideration must be given to the suitability of the material from which terminal and connecting fittings are made. Certain grades of steel are susceptible to hydrogen embrittlement as the result of contact with acids. This matter is dealt with in HSE guidance note PM39 'Hydrogen Embrittlement of Grade T Chain'. Other metals may be subject to corrosion. The advice of the supplier should always be sought when selecting roundslings and/or fittings for use in chemical environments

In-Service Inspection

In addition to the thorough examination necessary under statutory provisions, all roundslings should be visually inspected by a Responsible Person prior to use or on a regular basis. The interval between inspections will depend on the conditions of service but as roundslings are easily damaged in use, they should be visually checked on each occasion prior to slinging the load. If any of the following defects are found, the sling should be withdrawn from service and referred to a Competent Person:

- Exposed core. Some scuffing and general wear of the protective cover is acceptable provided the inner load bearing core is not exposed
- Cuts in the outer protective cover
- Failure of the stitching
- Heat and friction damage. Excessive heat, especially that generated by friction, will cause a smooth shiny area on the outer cover and may also cause internal damage. In extreme cases, fusion of the fibres occurs
- Weld splatter burns. Textile slings are often used in welding processes, as they insulate the work piece from the lifting appliance. Weld splatter will cause localised burning and may embed in the cover, causing abrasion, but is more likely to penetrate the cover and damage the inner core
- Chemical attack. Normally difficult to detect until advanced deterioration has occurred. In an advanced state, surface powdering occurs. Possible loss of colouring of the sleeve. Unless the manufacturer has agreed to such usage and a safe system of work has been agreed, slings exposed to chemicals (e.g. acids, alkalis, solvents) should be washed and cleaned in water and withdrawn from service for examination by a Competent Person
- Illegible marking or missing label; i.e. the sling identification mark and safe working loads
- Soiling. Heavy soiling can obscure damage, making detection during inspection difficult. It can also make identification difficult by obscuring any marking or colour coding. Grit and dirt

will pick up on the face of the cover and can cause rapid wear and abrasion. Clean the sling in an approved manner but if the soiling is such that cleaning has little or no effect, withdraw from service and refer to a Competent Person

Note: Only use cleaning agents approved by the manufacturer, whose instructions on its use must be sought and followed. Clean water may however be freely used.

Thorough Examination

A thorough examination should be carried out at intervals not exceeding six months in accordance with LOLER.

This interval should be less where deemed necessary in the light of service conditions.

The construction of roundslings is such that only the outer cover can be examined. The outer cover while being of the same material as the core is non-load bearing. If however the outer cover is undamaged then in the absence of any other evidence, the inner core can also be considered to be undamaged.

Assess the extent and severity of soiling. Heavy soiling can obscure damage, making detection difficult. It can also make identification difficult by obscuring any marking or colour coding.

Grit and dirt will pick up on the textile fibres and can cause rapid wear and abrasion. Where necessary they should be washed in clean water or in accordance with the manufacturer's instructions.

Check that the roundsling markings correspond with previous Reports of Thorough Examination (ROTE) and the Manufacturer's Declaration of Conformity (DoC).

Be aware you may come across slings in different locations around the world that have lesser Safety Factors, these slings do not meet the requirements of the European Machinery Directive upon which requirements this course is based.

These markings are required to be clear and legible.



If the textile roundsling has terminal fittings like master links and hooks fitted, then these should always be examined paying particular attention to:

- Master link twisting or signs of overloading
- Wear up to a maximum of 8%
- Corrosion
- Gouges in the link which can cause cuts to the fibre rope



- Hooks opening up and safety latches not operating correctly
- Hooks twisted
- Hooks corroded

Examine the roundsling cover for signs of chafing and localised abrasion. Some scuffing and general wear of the cover is acceptable providing the load bearing core is not exposed.

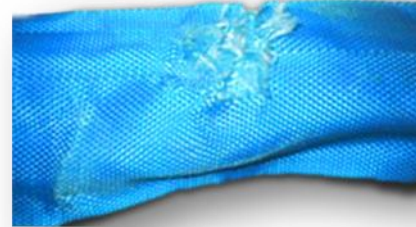

Examine the roundsling cover for holes which expose the inner core. Pay particular attention to the folds of the cover as even a small nick in the cover can deteriorate quickly and expose the core.

Examine the cover for signs of chemical attack which may be indicated by the flaking of the surface fibres which will then be able to be picked or rubbed off. Also look for paint and pen soiling as the contents of these may not be compatible with the roundslings properties.

Examine the cover for signs of heat and friction damage, this can be seen by the surface taking on a glazed appearance and signs of the fibres fusing together.



Examine the cover for weld splatter, as roundslings are often used in welding processes as they insulate the work piece from the lifting appliance. Weld splatter will cause localised burning and may imbed in the cover, causing abrasion, but is more likely to penetrate the cover and damage the core.



Examine the cover for damaged stitching or looseness of the threads.

Training

Operator training should take the manufacturer's instructions into account, paying particular attention to the following:

- Operatives should be familiar the methods of marking roundslings together with the mode factors which vary the safe working load according to the mode of use and assembly, e.g. choke hitch, basket hitch, single or multiple slinging, and fully understand how to apply them
- Operatives should be instructed in the correct selection of slings for varying applications, e.g. use with chemicals, and the steps to be taken if accidental exposure to chemicals occurs
- Operatives should be instructed in the meaning of colour codes, which denote the WLL of the component and the material from which the sling is constructed. Caution must be exercised, not only as some manufacturers may adopt alternative colour codes, but also as the operative may suffer colour blindness

Notes:

Shackles and Eyebolts

Shackles are probably the most common and universal lifting accessory, their uses are extensive. They may be used to connect a load directly to a lifting appliance, for the connection of slings to the load and/or lifting appliance, as the suspension for lifting appliances or as the head fitting in certain types of pulley blocks.

The LEEA Code of Practice for the Safe Use of Lifting Equipment, Section 19, deals with shackles and you should refer to this as part of your studies.

Although the old British Standards BS 3032, BS 3551 and BS 6994 have been withdrawn and/or declared obsolescent for several years, overseas manufacturers and their importing agents still make shackles generally to BS 3032 available. **The current Harmonised European Standard for forged steel shackles for general lifting purposes is BS EN 13889:2003, which is a standard for Dee and Bow shackles grade 6.**

There is an increasing popularity of shackles to US Federal specifications, RRC 271 and ISO 2415 – Forged shackles for general lifting purposes. ISO 2415 specifies the general characteristics of forged dee and bow shackles in a range of sizes having working load limits of from 0,32t to 100t and in Grades 4, 6 and 8, and presents their performance and critical dimensions necessary for their interchangeability and compatibility with other components.

Shackle Manufacture

Shackles are produced by forging.

US Federal specification and similar shackles are usually drop forged; this can be easily identified by the flash line around the body.

Old BS shackles were bent from billet bar so there would be no flash line.

In either case, the body of the shackle must be in a single piece and there should be no welding.

In either case the body must be in a single piece and there should be no welding.



Flash Line

Harmonised Standard BS EN 13889: 2003 allows for both methods, it says:

'Shackle bodies shall be forged hot in one piece. Excess metal from the forging operation shall be cleanly removed leaving the surface free from sharp edges. After heat treatment, furnace scale shall be removed.

Profiling of blanks other than by bending and forging shall not be used.

Shackle pins shall not be produced by a casting process.



No welding shall be carried out on any part of the shackle body or pin.'

Heat Treatment

After forging, but prior to machining and finishing, shackles are hardened and tempered.

Finish

Shackles are supplied in various surface finishes, depending on the standard to which they are made and BS EN 13889 permits many of these, e.g. descaled, electroplated, hot dip galvanised or painted.

Types of Shackle Body and Pin

There are two types of shackle pin in common use, the screw pin and the bolt, nut and cotter pin.

Whilst BS EN 13889 specifies and gives relative dimensions of the above pins it also permits other suitable forms of pin head within the specification.

Screwed pins with eye and collar are the most common type of pin and are suitable for a wide range of uses, however, if they are subject to movement and vibration, e.g. by a sling moving over the pin, they can loosen and unscrew.

The bolt with hexagon head, hexagon nut and split cotter pin is used where a positive connection is required as it cannot unscrew unintentionally. They are also ideal where a permanent connection is required, e.g. connecting the top slings to a spreader beam.



Screw Pin



Bolt, Nut and Pin

Bow shackles are designed to enable three or more items to be joined.





Dee shackles are generally used for joining two items in a straight line.

Wide Body Shackles

These shackles provide a larger radius surface area to ease the stresses imposed on the lifting slings.

When carrying out the thorough examination, you are to measure wear from the top of pin to the inside of shackle crown (intrados).

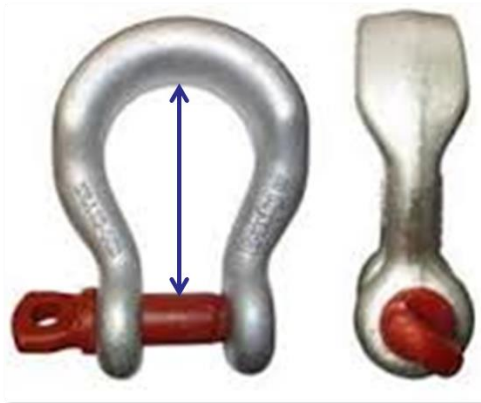

Shackle

Marking

BS EN 13889 requires that each shackle is legibly and indelibly marked with the following information, by the manufacturer:

- Working Load Limit in tonnes
- Grade mark
- Manufacturer's name, symbol or code



- Traceability code
- Mandatory markings (e.g. CE marking)

BS EN 13889 requires that pins of less than 13mm diameter are marked with either:

- Grade mark or,
- Traceability code
- Pins greater than 13mm diameter are marked with:
 - Grade mark
 - Traceability code
 - Manufacturer's symbol



Stress in Shackles

A shackle is designed so that the strength of body and pin are approximately equal (pin will larger in diameter than the body) Pin acts as a beam and if subject to a point load, it will be both in a condition of bending and of double shear.

If the jaw is fully filled (load spread evenly over the full width of the pin) it will only be in double shear. For a point load, the maximum tensile stress occurs at the centre on the outward facing side of the pin.

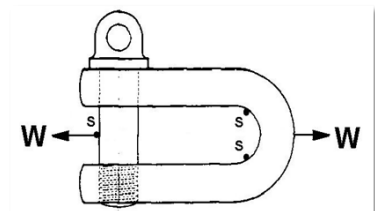
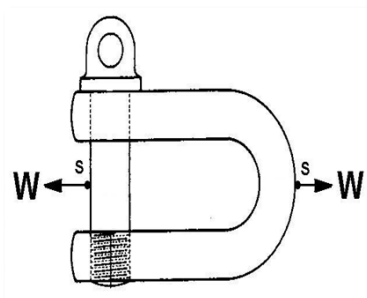

Dependent on the proportions of the shackle body, the maximum stress may occur either at the outside on the crown of the body or at the inside of the sides of the body as shown.

Manufacturers Tests

Type Tests

To prove the design, material, heat treatment and method of manufacture, and to ensure that the shackles possess the necessary mechanical properties, BS EN 13889 requires that the manufacturer makes certain type tests. The type tests have to be repeated if there is any change of design, specification of material, heat treatment or method of manufacture. The type tests to be made are:

- Test for deformation on three samples

- b) Static tensile test on at least three samples
- c) Fatigue test on three samples
- d) Charpy impact test on test pieces taken from at least three samples

Manufacturers with an accredited EN ISO 9001 certification

If the manufacturer has a quality system conforming to EN ISO 9001 certified by a certification body accredited to EN 45012 the following tests and examinations must be made:

Proof load test

If the production batch is between 1 and 3000 off, they must proof load test 3% of the batch. This decreases to 2% for batches of 3001 to 5000 and to 1% for batches of more than 5000. A manufacturer may elect to operate an alternative test regime of 2% of all his production, irrespective of the size of the batches. The proof load applied is twice the WLL.

Non-destructive test

After heat treatment and de-scaling all bodies and pins must be subjected to magnetic particle or dye penetrant examination.

Visual examination

All shackles must be visually examined. The examination can be carried on the completed shackles or in stages during the production provided that all relevant features are examined.

Manufacturers without an accredited EN ISO 9001 certification:

If the manufacturer does not have a quality system conforming to EN ISO 9001 certified by a certification body accredited to EN 45012 the following tests and examinations must be made:

Proof load test

All of the production batch must be proof load tested to twice the WLL.

Static test and Charpy impact test

One sample per production batch must be subjected to a static test and three samples must be subjected to a Charpy impact test.

Non-destructive test

After heat treatment and de-scaling all bodies and pins must be subjected to magnetic particle or dye penetrant examination.

Visual examination

All shackles must be visually examined. The examination can be carried out on the completed shackle or in stages during the production provided that all relevant features are examined.

Safe Use of Shackles



The correct shackle body and pin must be used and they must be of the same grade. Accidents have occurred where the user has put a mild steel pin in an alloy steel body or replaced a screw pin with a nut and bolt.

The shackle must be compatible with all of the other fittings in the slinging arrangement, taking account of increased resultant loads due to angular loading, and it must seat correctly with mating parts. If the shackle jaw is too small it will be forced open and/or bent and if it is too wide the shackle may twist under load and take on a permanent set.



The pin must be correctly screwed into the shackle eye, i.e. finger tight, so that the collar of the pin is fully seated on the shackle eye.

The pin must be the correct length so that it penetrates the full depth of the screwed eye and allows the collar of the pin to bed on the surface of the drilled eye with a maximum of 1½ turns of thread remaining exposed in the jaw.

Shackles which have a positively locked pin, e.g. bolt, nut and split cotter pin, should be used for applications where the shackle cannot be observed or where the pin may unscrew when in service

and, in the worst case, release the load. The pin will become scored and gouged if it has been unscrewing, even by a small amount, under load and this will lead to stress raisers.

Eccentric loading will cause the shackle to twist:

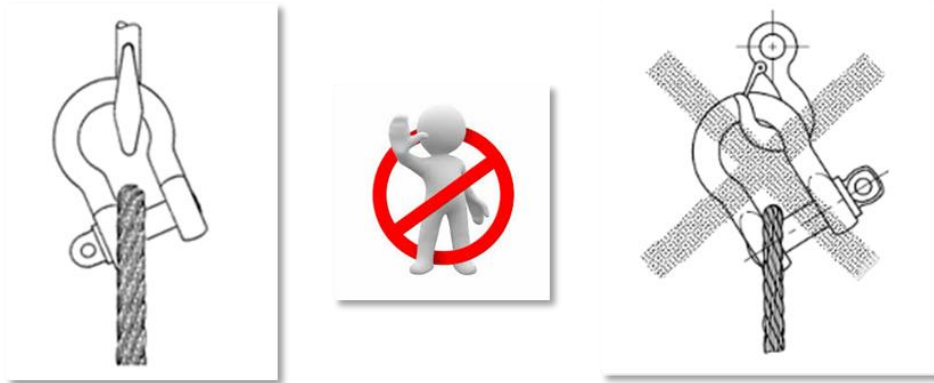

Pre-Use Inspection

Before use, the user should carry out a pre-use inspection of shackles, as follows:

- Check the body and pin are identifiable (same size, grade, type, make etc.)
- All markings must be present and readable
- No damaged threads to the pin or body
- No distortion to either the body or the pin
- No excessive wear evident
- No identifiable cracks, cuts, nicks or gouges

If any of the above are found, refer the shackle to a competent person for further advice – do not use the shackle!

Thorough Examination

Shackles fall under the heading of 'lifting accessories' in modern legislation and therefore should be examined by a competent person at periods not exceeding 6 months.

Nothing will be achieved by a load test during the examination of in-service shackles as the strength is known prior to the examination. Indeed, such a test can be damaging if the item is worn but within acceptable limits.

In-service shackles should therefore be carefully visually examined. In particular the following should be checked:

- Free working of the pin
- The threads, both male and female, should be fully formed with no flats or worn portions and must be full size. There should be no excessive play when the pin is screwed in by hand from either the correct or reverse side
- Holes must align. The pin hole should not be too large so as to allow a gap when the pin is in place
- LEEA recommends that the maximum permissible wear is 8% reduction in material diameter on either the pin or the body
- There should be no signs of nicks, cracks, corrosion or chemical attack
- There should be no distortion. The body should have a good shape and the pin must show no signs of bending
- Marking should be clear and legible

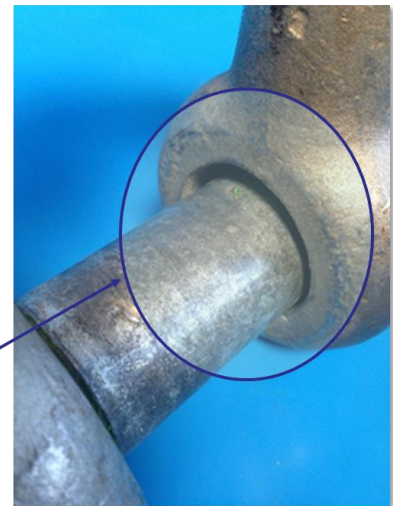

- Max diameter of unthreaded hole in shackle body (BS EN 13889) 1.1 x pin diameter or +1.5mm (whichever is the greater)

Distortion Due to Incorrect Use:

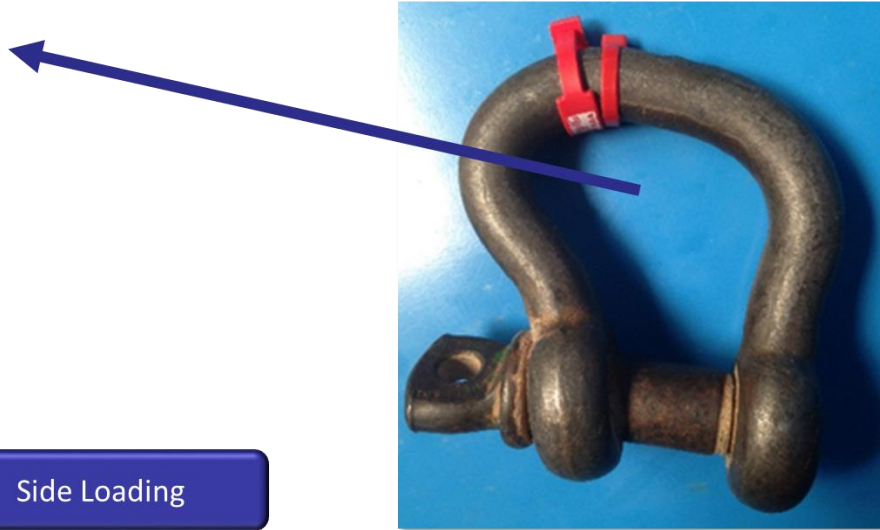

Side Loading

Incorrect Shackle Pin Fitted:

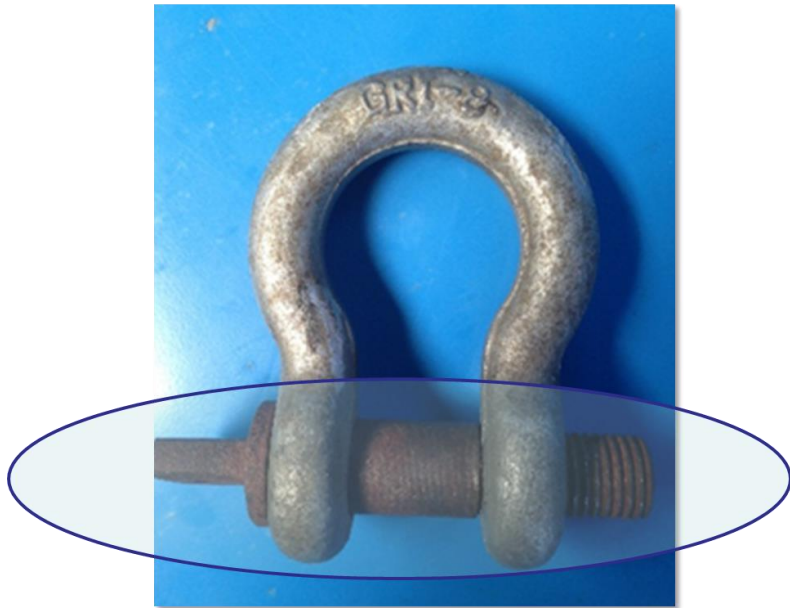

Notes:

Thorough Examination

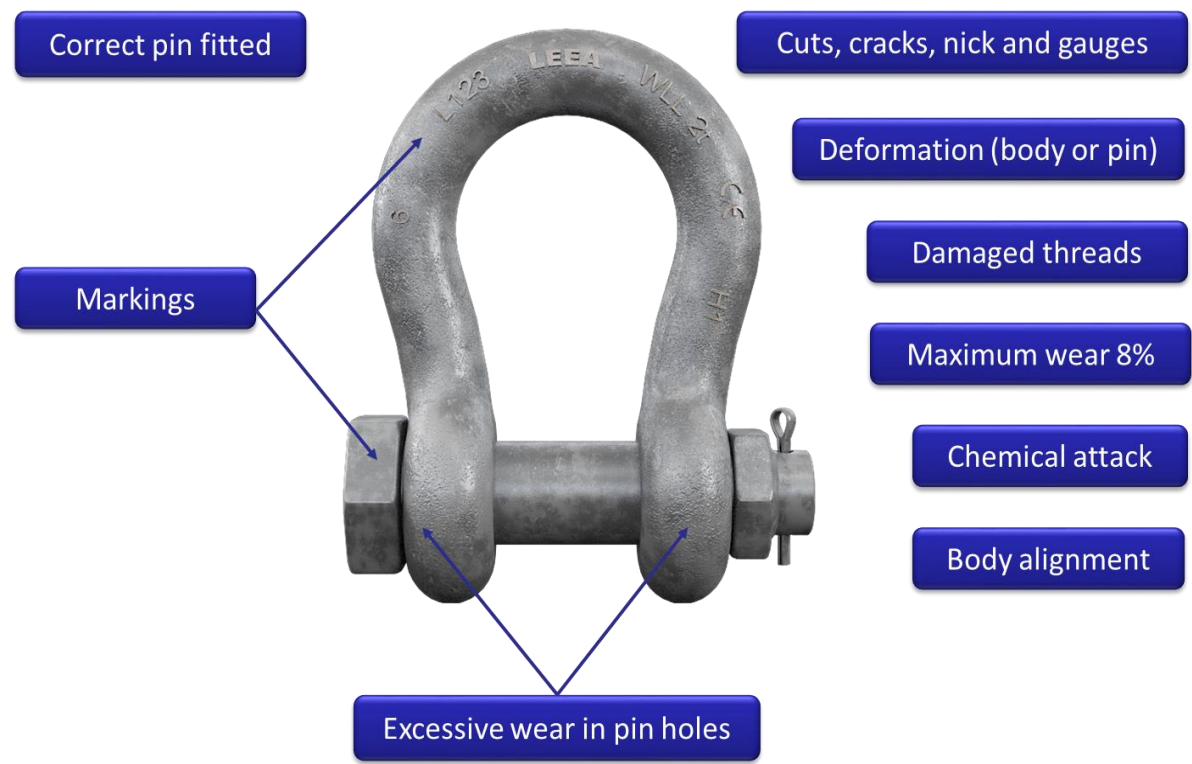
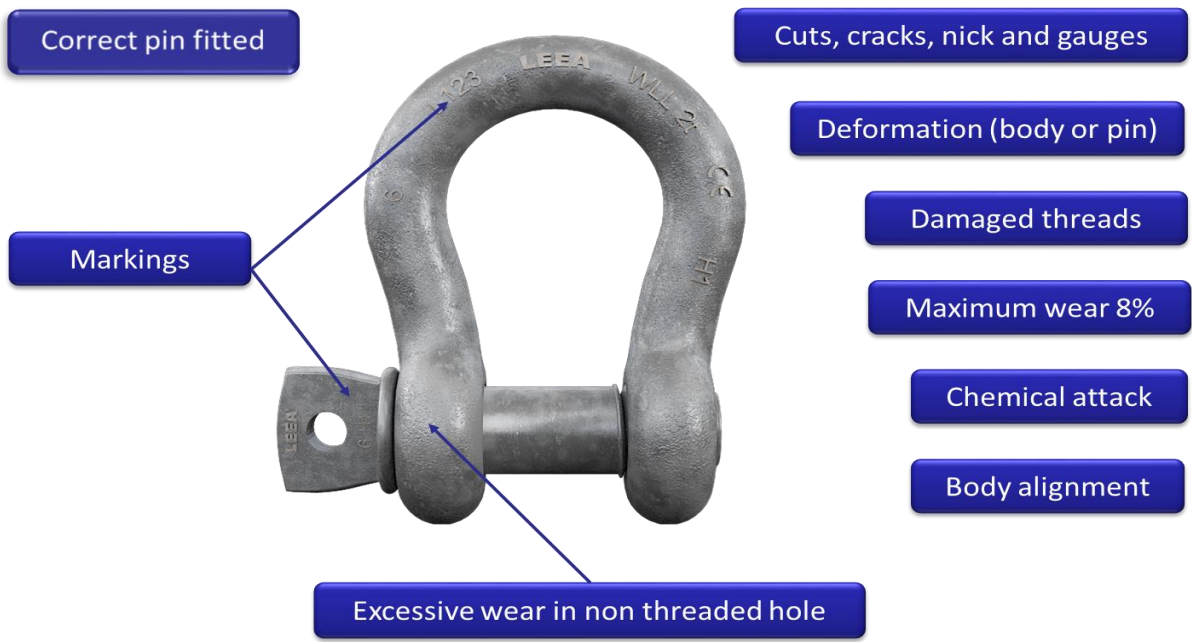

Replacement Shackle Pins

Can a shackle pin be replaced?

Providing the pin and the body do not come from different manufacturers and that the correct type of shackle pin is fitted and that the pin meets the fit requirements specified in EN 13889 - or the standard to which it was made- then there is no reason to reject a shackle because it has a new pin fitted.



Training

Operatives should be instructed in the correct selection and adjustment of shackles for varying applications. The LEEA COPSULE, section 19, contains important user information.

Notes:

Eyebolts

Although eyebolts are one of the most common lifting accessories they have severe limitations in usage, which are often not fully understood, and many accidents result from misuse.

This is extensively covered in Section 20 of the LEEA Code of Practice for the Safe Use of Lifting Equipment, which you should read in conjunction with this book.

The current Harmonised European Standard for eyebolts is BS EN ISO 3266:2010, covering metric thread collared eyebolts, grade 4. This standard specifies the dimensions of the eyes of eyebolts that permit a direct connection with shackles of the same WLL identified in ISO 2415.

Eyebolts that comply with the British Standard, BS 4278: 1984, will fall within the manufacturing requirements of the standard and consideration within this unit is confined to these. Note that the general matters dealt with here can also be applied to eyebolts complying with other standards. Some background information is also necessary, as many of the eyebolts found in service will be of a commercial pattern and may not be suitable for lifting applications.

BS EN ISO 3266:2010 does not cover eyebolts that are not forged as one piece.

BS EN ISO 3266 Eyebolt Types



BS 4278 Eyebolt Types



Collared



Dynamo

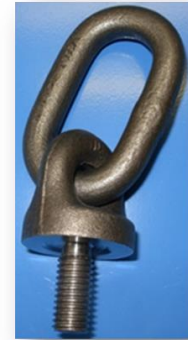

Collared with Link

Metric, BSW and UNC threads available

BS 4278 Dynamo Eyebolt

- Large eye sitting on a small collar but not blended into that collar
- Eye will bend if side loaded
- Shank will bend or crack as the collar offers little support
- Axial loading only



BS 4278 Collared Eyebolt

- Eye not large enough to accept a hook so a shackle must be used.
- Shims up to a maximum of $\frac{1}{2}$ of 1 thread for alignment purpose can be used so as not to stress the shank.
- May be used in pairs of the same capacity provided that recommended limitations of loading are strictly followed (see relevant LEEA technical publications for further information)



BS 4278 Eyebolt with Link

- Can be used in any direction up to the stated SWL although the angle of the load to the axis of the screw thread of the eye does not exceed 15°
- Can be used for non-axial loading at inclinations greater than 15° but the SWL must be correctly reduced
- SWL is greater than the collar eyebolt when used in the same scenario, but the load can be applied at any angle to the plane of the eye

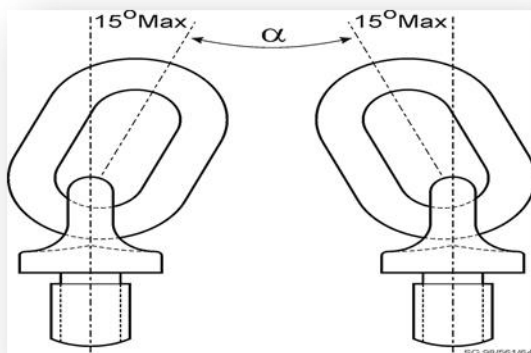

Eyebolt Manufacture

The eyebolt, including the shank, shall be forged in one piece without welding.



The underside of the collar shall be machined in true alignment at right-angles to the axis of the shank.

The shank shall be screwed concentrically with the outside diameter of the collar.

The thread run-out and recess shall be smoothly radiused and free from surface irregularities.



Machined Undercut



Thread Run Out

Marking (ISO 3266)

Each eyebolt shall be legibly and indelibly marked in a manner which will not impair the mechanical properties of the eyebolt. This marking shall include at least the following information:

- a) The manufacturer's identification mark or symbol
- b) The nominal size, i.e. nominal diameter of thread e.g. 24
- c) The axial working load limit in general service e.g. WLL 2.5t
- d) The traceability code to enable any particular eyebolt or batch of eyebolts to be identified with the manufacturer's certificate
- e) CE marking

Manufacturers Tests

Manufacturing proof test

After removal of the force, there shall be no visible defect, and the dimensions shall be within the tolerances specified on the manufacturer's drawing.

Where finishing processes are used that involve a risk of eyebolt embrittlement, e.g. acid cleaning or electroplating, the proof force is re-applied to the eyebolt in its finished condition.

Non-destructive testing

After heat treatment, the surfaces of the eyebolt are NDT tested using either magnetic particle or dye penetrant examination.

Manufacturers Documentation

The manufacturer shall provide a declaration with each consignment of eyebolts giving the following information for the consignment:

- a) Business name and the full address of the manufacturer and, where applicable his authorized representative
- b) Number of this International Standard, i.e. ISO 3266
- c) Quantity and description of the eyebolts
- d) Traceability code to enable any particular eyebolt or batch of eyebolts to be identified
- e) Working load limit, expressed in tonnes
- f) Proof force applied, expressed in kilonewtons

Safe Use of Eyebolts (ISO 3266)



Eyebolts may be used up to the marked working load limit, for axial loading only.

Eyebolts may also be used for inclined loading provided that the WLL is reduced by the appropriate factors:

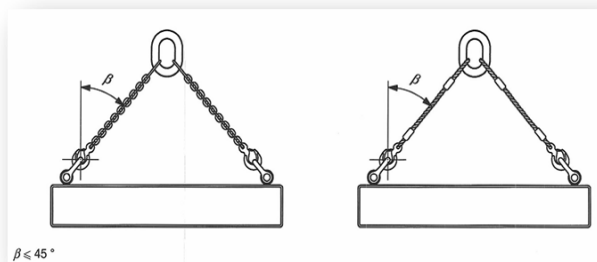
1	2	3	4	5*
Nominal size Nominal diameter of thread <i>d</i> mm	Working load limit WLL t	Axial proof force kN	Minimum axial breaking force kN	Maximum working load of a pair when $0 < \beta \leq 45^\circ$ (1,4 x WLL) t
8	0,2	4	8	0,28
10	0,32	6,4	12,5	0,44
12	0,4	8	16	0,56
16	0,8	16	32	1,12
20	1,6	32	63	2,24
24	2,5	50	100	3,5
30	4	80	160	5,6
36	6,3	125	250	8,82
42	8	160	320	11,2
48	10	200	400	14
52	12,5	250	500	17,5
56	16	320	630	22,4
64	20	400	800	28
Nominal diameter of thread x pitch <i>d x P</i>				
72 x 6	25	500	1 000	35
80 x 6	32	630	1 250	44,8
90 x 6	40	800	1 600	56
100 x 6	50	1 000	2 000	70



Safe Use of Eyebolts (BS 4278)

Safe Working Load = Constant x WLL				
	Eyebolt Type	15° <	15° <> 30°	30° <> 45°
	Collar	0.63	0.4	0.25
	Link	1.0	0.8	0.63

BS 4278 Eyebolts used for Trunnion Lifting - Loading is at 90° to the eyebolt shank axis

- Collar Eyebolt 25% of the marked SWL (0.25)
- Eyebolt with link 63% of the marked SWL (0.63)

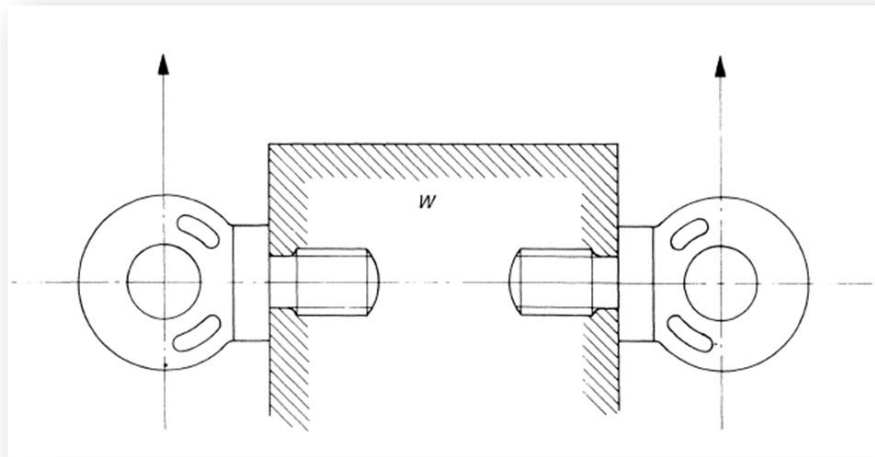

When used in pairs, eyebolts should be aligned within $\pm 5^\circ$ of the plane of the eye:

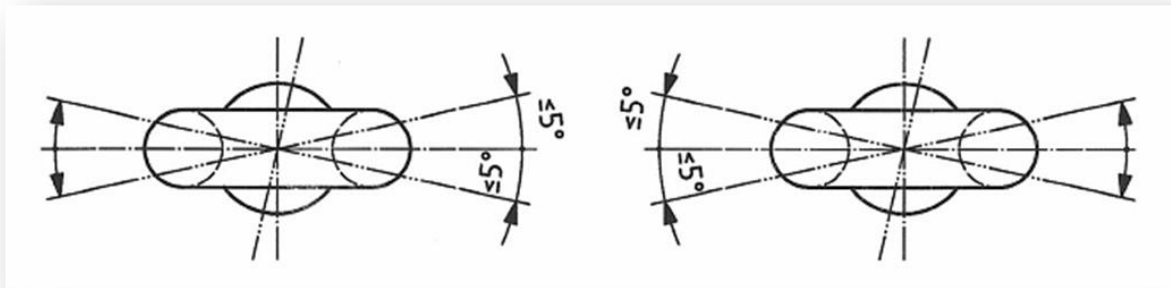

Due to the nature of the eyebolt, the eye of may be too small to provide a direct hook connection. In this case a shackle should be used to facilitate connection.

Temperature

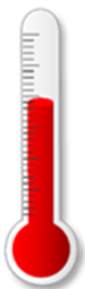

Eyebolts should only be used within the temperature range of -20°C to 200°C . Intended use of eyebolts outside this temperature range should always be referred to the manufacture before actually using them.

Pre-use Checks

Eyebolts should only be used by an appropriately trained person who should carry out a pre-use inspection before fitting. This should include:

- a) Markings should be legible
- b) Threads should be free from wear, corrosion and damage
- c) There should be no debris present in the thread
- d) There should be no distortion of the eyebolt, i.e. bent shank, deformed eye, reduced diameter at the undercut, nor should any damage, i.e. nicks, cracks, gouges, or corrosion, be present.

Reeving

A sling should not be reeved directly through the eyebolts or through shackles fitted to the eyebolts as this will result in the angular loading of the eyebolt being considerably increased.

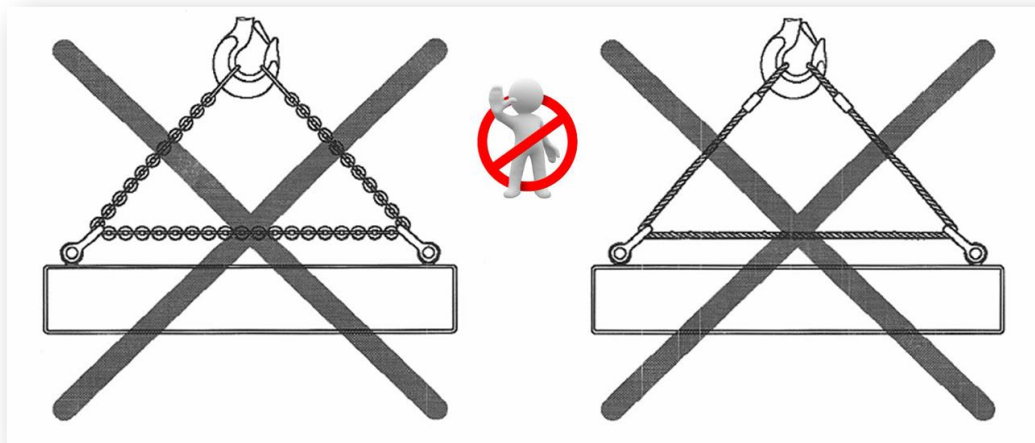

The eyebolt should be firmly screwed down without over-tightening, hand-tight only.

If a single eyebolt is used for lifting a load which is liable to revolve or twist, a swivel type hook should be used to prevent the eyebolt unscrewing.

Care should be taken to ensure that the tapped hole has sufficient threaded length to engage the eyebolt shank fully and that the material of the tapping is of adequate strength.

Thorough Examination

Eyebolts fall under the heading of 'lifting accessories' in modern legislation and therefore should be examined by a competent person at periods not exceeding 6 months.

Nothing will be achieved by a load test during the examination of in-service eyebolts as the strength is known prior to the examination. Indeed, such a test can be damaging if the item is worn but within acceptable limits.

In-service eyebolts should therefore be carefully visually examined. In particular the following should be checked:

- Threads should be fully formed with no wear, flat areas or signs of cross-threading etc.
- Shank should be correctly aligned, it should be central to the collar and the axis at 90° to the collar face. Particular care must be given to the examination of the junction of the shank and collar; there must be no signs of necking or cracking
- The shank must not show any signs of bending and under no circumstances should any attempt be made to straighten bent shanks
- The face of the collar should be even and undercut around the shank so that it will seat evenly on its mating surface. Any burrs should be carefully removed with a fine file
- The general condition of the forging should show no signs of corrosion, chemical attack, nicks, cuts or gouges
- The marking should be clear, but not too deep and this will act as a stress raiser
- The eye should show no signs of bending or distortion. The maximum permissible wear is an 8% reduction in material diameter

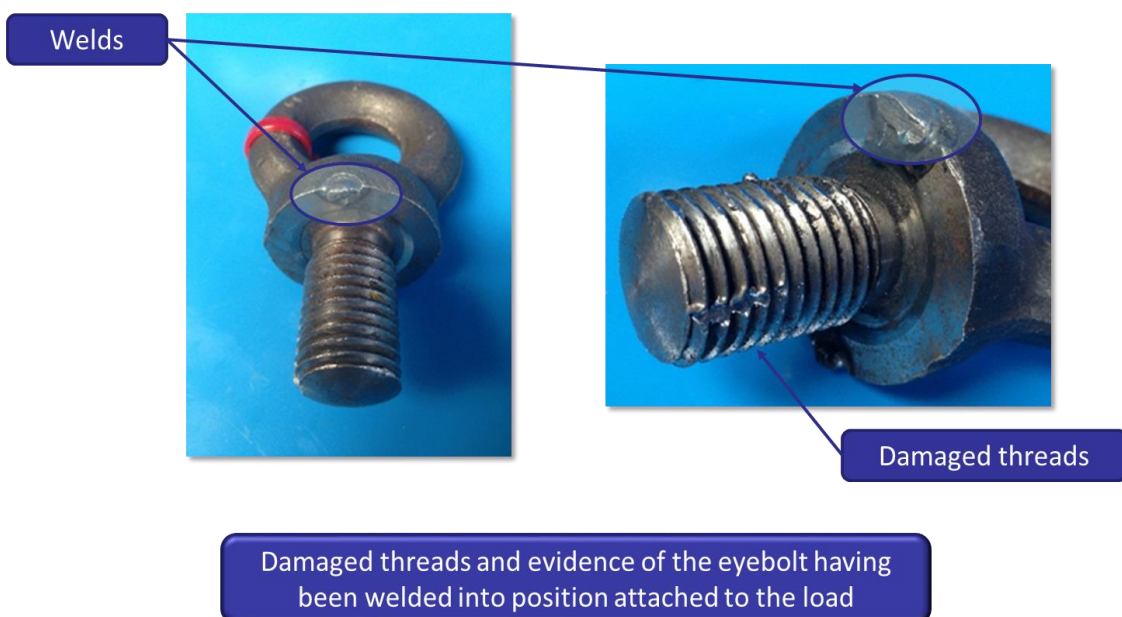



Dangerous Practice



An eye nut with a threaded bar welded into it to make an eyebolt



A bolt welded to a piece of steel pipe section to make an eyebolt

Rigging Screws and Turnbuckles

Rigging screws and turnbuckles are used to for the tensioning and fine adjustment of length in lifting assemblies and stays where chain, wire rope or textile element form the main component of the assembly. They can also be used on their own for some applications. Further uses include cargo restraint, suspension, etc.

BS 4429: 1987 covers two distinct types:

- Rigging screws, which have a tubular body, with threads in the range 8mm – 100mm
- Turnbuckles, which have an open drop forged body, with threads in the range 8mm – 72mm

The standard requires rigging screws and turnbuckles used in lifting applications to be proof-load tested and stamped with the working load limit.

US Federation Specification FF-T-791b, Type 1, Form 1 also details a range of turnbuckles in the range ¼" to 2 ¾" (0.25" to 2.75") for such lifting applications.

Rigging Screws

A Rigging Screw has a tubular body, internally threaded at each end, with one right hand and one left-hand thread connecting to terminal fittings of various forms, e.g. screwed eyes, hooks or forks. They are also known in some industries as bottle screws.

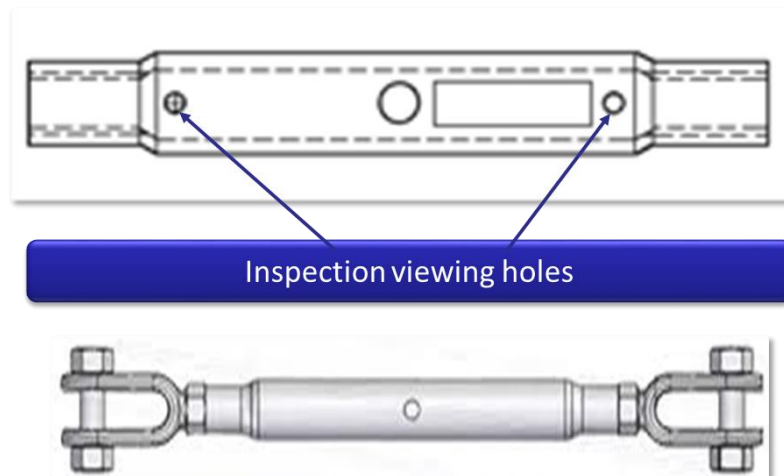

Notes:

Turnbuckles

The principles of the operation of the turnbuckle is to have the screws operating clockwise and counter clockwise to close the eye or opening between two end fittings. It consists of an open body consisting of reins, with internally threaded bosses at each end, with one right and one left-hand thread connecting to terminal fittings of various forms, e.g. screwed eyes, hooks or forks.

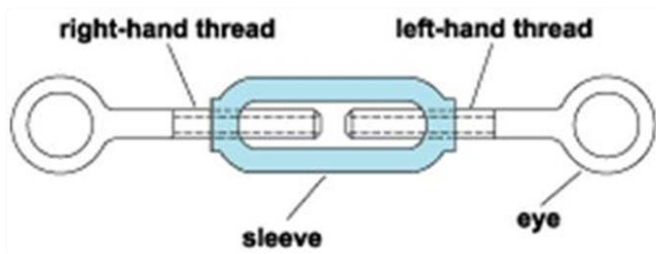
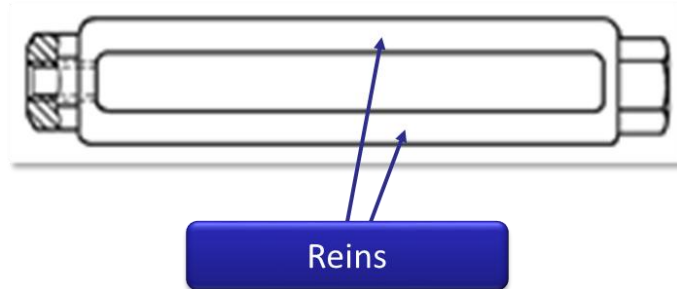

Types of Rigging Screws and Turnbuckles



Turnbuckle with screwed elongated eye terminal fittings

Rigging screw with screw fork terminations



Turnbuckle with screwed trapezoidal hook terminal fittings



Manufacturers Testing Requirements

After manufacture, each rigging screw or turnbuckle is subjected to a proof load of 2 x SWL, showing no signs of permanent deformation. Testing shall be conducted with the item in the fully open (fully extended) position.

A thorough examination is to be conducted on each item following proof load testing.

Principles of Selection

Working Load Limits (Imperial Thread Rigging Screws and Turnbuckles)

Thread Diameter (Inches)	Working Load Limit (tonnes)
0.375	0.45
0.5	0.5
0.625	0.75
0.75	1.2
0.875	1.7
1.0	2.2

Working Load Limits (Metric Thread Rigging Screws and Turnbuckles)

Thread Diameter (mm)	Working Load Limit (tonnes)
10	0.3
12	0.5
16	0.75
20	1.25
22	2.0
27	3.0

Strength

A rigging screw or turnbuckles must have a working load limit at least equal to the load that will be imposed on it, taking account of the angle of use. Care must also be taken to ensure that it is compatible in size with any mating equipment.

Length

The working range between maximum and minimum length must be adequate for the application.

Safety / Vibration

Where vibration may occur, locknuts or other suitable methods of securing must be used, e.g. wire seizing. If locknuts are used, the closed dimension will be increased by twice the dimension of one locknut.

Lock Nuts

Where vibration can occur, lock nuts must be fitted between the termination accessory and the body to prevent the thread opening up. This will increase the closed dimension which should be taken into account.

Marking

Rigging screws and turnbuckles used for lifting purposes should be marked with the following information:

- Working load limit in kilograms or tonnes
- Identification mark traceable to the manufacturer's / supplier's documentation
- Manufacturer's name or identification
- Traceability code on all load bearing components, i.e. body, eyes, hooks, forks, etc.
- CE Marking

Markings should be applied positioned as shown on a tubular body, or in the centre of the length of one of the reins.

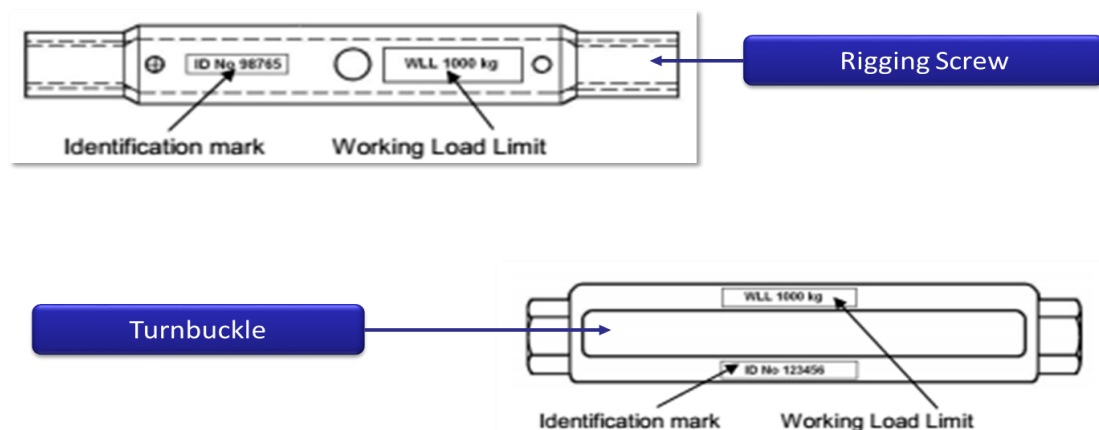

Documentation

Rigging screws used for lifting applications fall within the definition of lifting accessories given in the European Machinery Directive.

The manufacturer should therefore issue an EC Declaration of Conformity for new items. Although not required by legislation, new rigging screws which comply with BS 4429:1987 and are specified as suitable for lifting applications should also be accompanied by a manufacturer's record of proof load testing.

This may be as a separate document or combined with the EC Declaration of Conformity.

The **EC Declaration of Conformity** documents form an important part of the record of the rigging screw. They should be retained and cross-referenced to the rigging screw's historical records for inspection by the Competent Person or HSE.

Thorough Examination

The definition of lifting equipment and accessories used in LOLER also make it clear that rigging screws and turnbuckles fall under the heading of lifting accessories.

Unless a written scheme of examination, drawn up by a Competent Person, is in place and operating they must be thoroughly examined by a Competent Person at intervals not exceeding 6 months.

Reports of thorough examination should be retained and cross-referenced to the components historical records for inspection by the Competent Person or HSE.

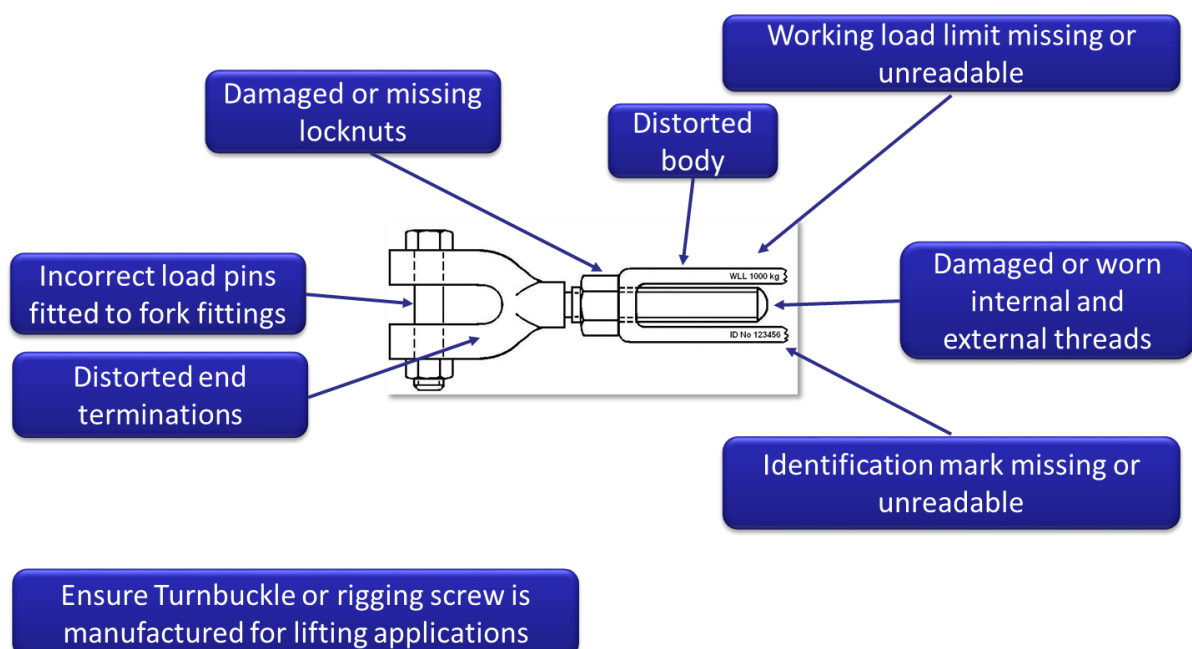

Safe Use of Rigging Screws and Turnbuckles

In addition to any specific instructions relating to the safe use of the rigging screws issued by the manufacturer, the following points should be observed:

Never exceed the safe working load for the particular mode of use.

- When used in a multi-leg assembly, an allowance must be made for the angle of the sling leg to the vertical
- Take care to ensure that it is compatible in size with any mating equipment
- Rigging screws should be fitted in a manner that allows the body and end terminations to align straight along their centre line, and not in a way that bending loads are induced. They should not be used in slinging applications where they are likely to become bent, e.g. positioned around the corner of a load
- The terminal fittings must be fully screwed through the female threads. A minimum length of at least 1.6 times the thread diameter should be maintained within the body at each end
- The inspection hole (if available) in the rigging screw body should be kept clear so that the position of the screw of the terminal fitting relative to the body can be seen. Where there are no viewing /inspection holes it is advisable to remove the end termination and measure the length of screwed shank to verify the minimum length of thread required for adequate and safe engagement
- The inside length of the eyes, when measured flat using a steel tape or rule graduated in increments of 1 mm, shall be of the following minimum dimensions:
 - Three times the width of the webbing for width of up to 150 mm
 - Two and a half times the width of the webbing for widths greater than 150 mm
- Preferred Types of Eyes

Notes:

In-Service Inspection

If any of the following defects are present they should be withdrawn from service and referred to a Competent Person:

- SWL or other markings missing or illegible
- ID mark missing or illegible
- Damaged screw thread
- Corroded screw or tight in operation
- Distorted body or fittings
- Nocks, cracks, cuts or gouges

Information which should be exchanged between the user and the designer or supplier

The purchaser should ensure that any order includes the following information:

- Type of component required, i.e. rigging screw or turnbuckle
- Finish required, i.e. self-colour or hot-dip galvanized
- Type of terminal fittings required
- Whether locknuts are required
- Thread diameter and/or WLL required
- Maximum and minimum length required or range of adjustment required
- Applicable manufacturing standard
- State that the item is to be used for a lifting application and should be verified and certified accordingly
- Details of the application if known

Training

Operatives should be instructed in the correct selection and adjustment of rigging screws or turnbuckles for varying applications, e.g. use with wire rope or chain assemblies.

Plate Clamps

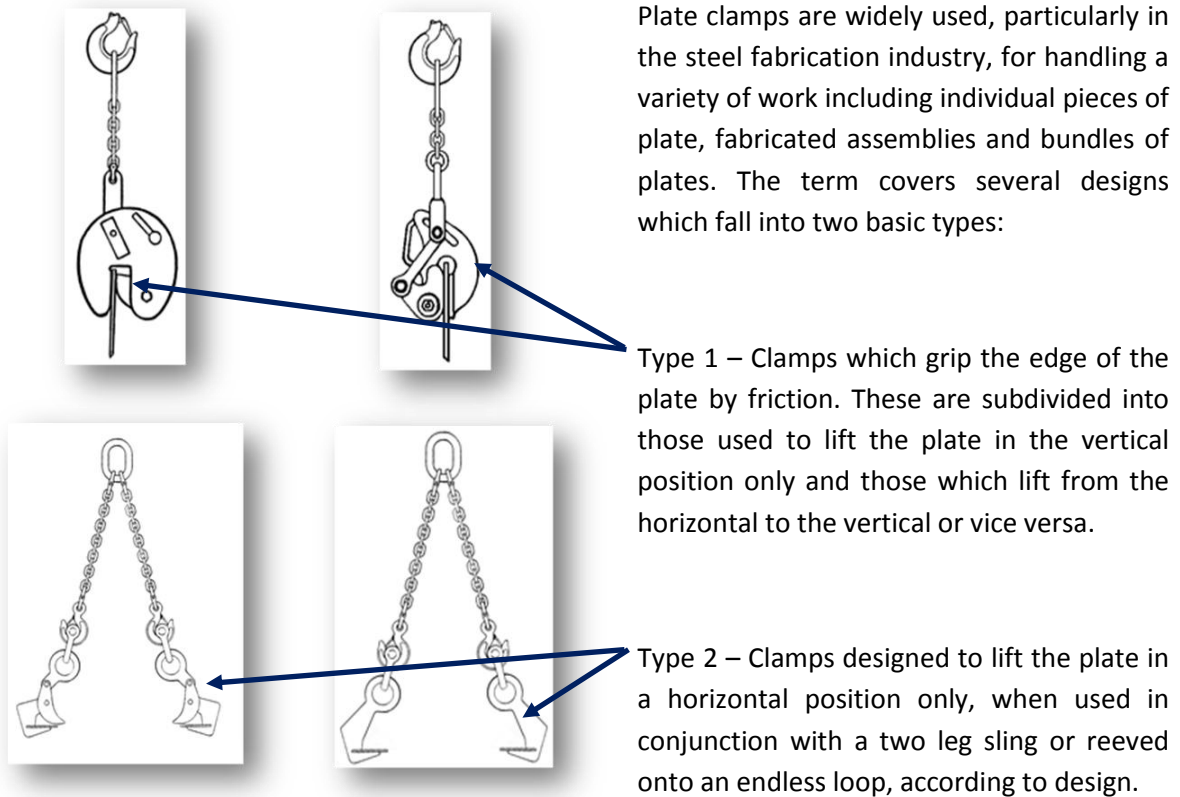

190

This section of the course covers both vertical and horizontal plate handling clamps. Such clamps are within the scope of BS EN 13155: 2003 + A2: 2008, Cranes – Safety – Non-fixed load lifting attachments.

Prior to this standard there was no British Standard for plate clamps and, as a result, most manufacturers produce a range of plate handling clamps to their own specifications.

Plate handling clamps can have a long life. It is not therefore possible in a general purpose code to cover every variation and for certain designs special precautions or instructions may apply.

The manufacturer's or supplier's instructions should always be sought and followed.

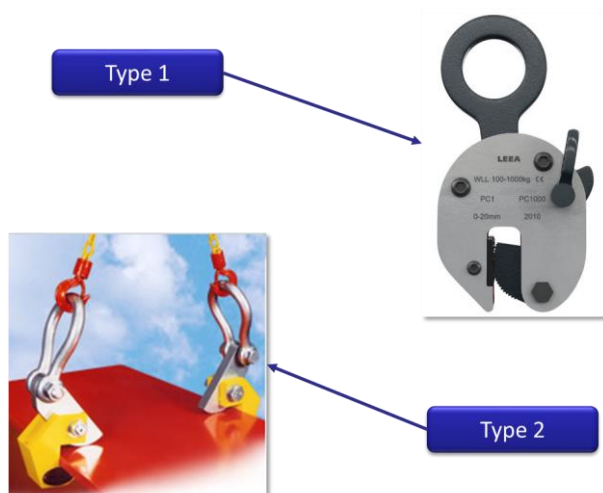

Operation of Plate Clamps

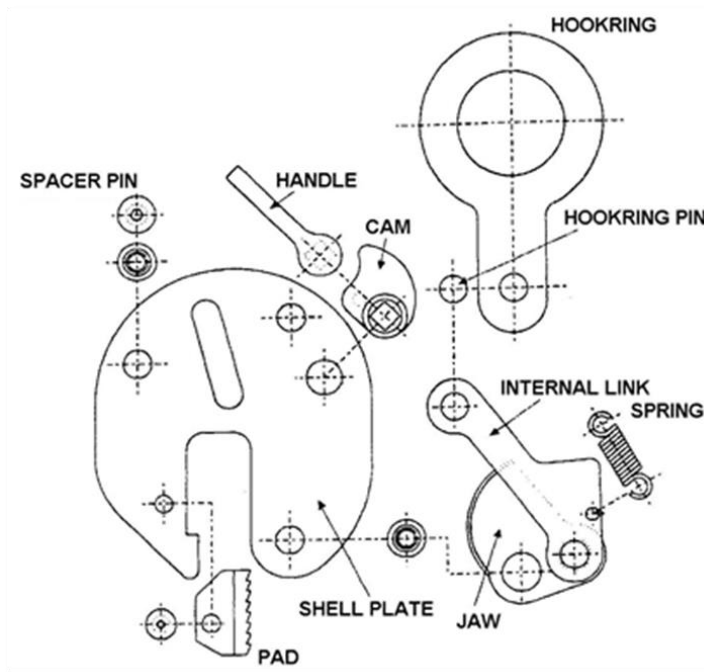

This illustration shows an exploded view of a typical vertical plate clamp.

When a plate is placed in the jaw of this type of plate clamp the handle is used to close the jaw by pushing a cam onto the link lever.

Upward movement of the hook ring places an increased gripping action onto the jaw via the linking lever, which is also spring assisted.

The Vertical plate Clamp

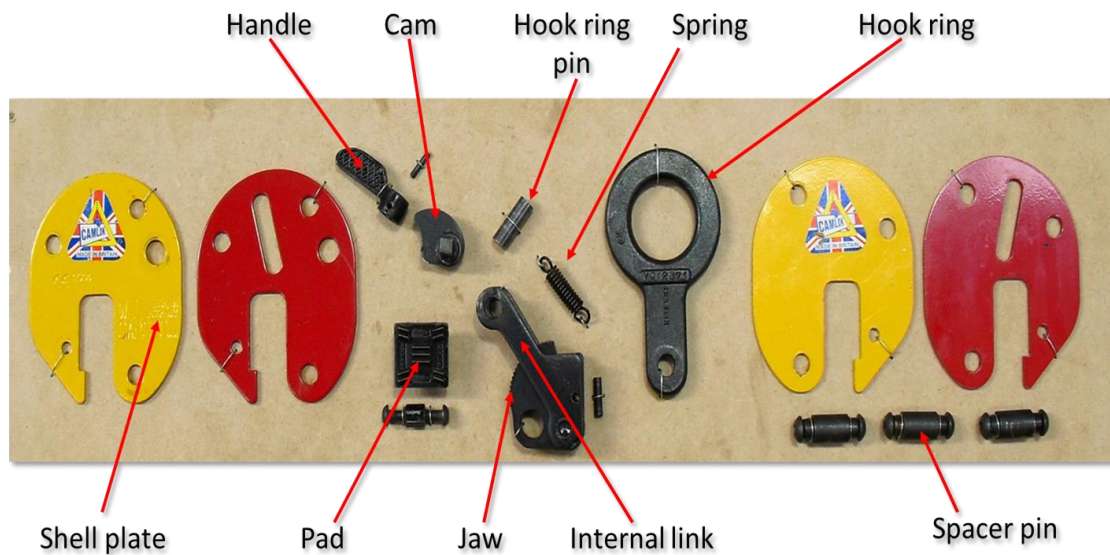

Internal Views of the Vertical Plate Clamp Mechanism

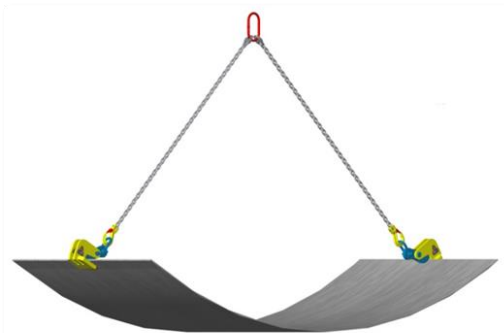

Operation of Horizontal Plate Clamps

In the case of horizontal clamps with a toe, or toe and tongue, these are always used with a chain sling arrangement. The plate simply sits on the toe the only grip given to the plate is the natural gripping action of the sling legs trying to close together. Where the clamps have a tongue, this is also caused to grip the plate by the natural action of the sling.

Horizontal clamps are designed to be used in pairs, either with a two leg sling or with a chain made endless to a link. It is important to note they should never be exchanged one for the other as the geometry of the arrangement and therefore the gripping forces would be altered from that for which the clamps were designed.

Safety Requirements of EN 13155

Mechanical Strength

Withstand a static load of 2 times the WLL without any deformation taking place.

Withstand a static load of 3 times the WLL without release of the load even if permanent deformation takes occurs.

Prevention of Unintentional Release

The clamp must be designed so that it will not release the load unintentionally, e.g. by accidental contact with an obstacle, the weight of the hook bearing down on the clamp, when tipping and/or turning a load or when setting the load down.

Safety of Frictional Grip

There must be a safety factor of at least two to prevent a plate slipping out of the clamps grip. To compensate for manufacturing tolerances and elastic deformation, in order to maintain this factor a further allowance must be made on the minimum thickness of plate the clamp may lift as follows:

- For minimum plate thickness of 50mm or less = 10% of design minimum thickness
- For minimum plate thickness between 50mm and 100mm = 5mm
- For minimum plate thickness of more than 100mm = 5% of design minimum thickness

Attachment to Lifting Device

The method of connection to the crane or hoist must ensure that the forces are transmitted through the clamp in the correct alignment.

Safety Requirements of BS EN 13155

Type 1

- Clamps should have been tested to a proof load of 2 x working load limit without showing permanent deformation and in samples tested to destruction they should not have released the load at less than 3 x the working load limit
- In the case of clamps designed to lift at an angle to the side plate of the clamp, there should have been an additional test at the maximum angle permitted, of 2 x the WLL for that angle
- A design that permanently incorporates a short length of chain connecting the clamp to the crane hook is strongly recommended in preference to an eye
- Proof load tests should be carried out on the thinnest plate practicable within the clamps range
- The range of thickness that may be lifted should be indicated on the clamp
- It is desirable that the gripping cams and jaw teeth are easily replaceable

Note for Type 1 clamps:

Some designs of clamp, particularly those with a moving cam action jaw where the initial grip is provided by a spring, have a minimum load and minimum plate thickness they can safely lift.

Wherever possible refer to the manufacturer's instructions, but in the absence of specific guidance the load should not be less than 20% of the SWL and the plate thickness not less than 20% of the maximum.

Type 2

Clamps should have been tested to a proof load of 2 x the working load limit. The proof load should be applied at the angle(s) between the legs of the sling at which the maximum stresses occur in the clamps, without showing permanent deformation. In samples tested to destruction, they should not have released the load at less than 3 x the working load limit.

The provision of handles on the heavier clamps aids handling and prevents pinched hands.

This type of clamp may not be suitable where there is a tendency for the plate to sag when lifted. In this context, it should be noted that clamps designed for use on an endless loop usually exert a greater crushing force which aggravates the problem.

Type Verification

EN 13155 requires the manufacturer of plate clamps to carry out various type tests to prove the design on one or more samples. These include:

Static overload test at 3 x the WLL ($\pm 2\%$) which replicates the conditions of use, held for a minimum period of 1 minute. The load must be held even if there is permanent deformation.

Test to ensure no accidental load displacement when landed or in the case of an impact. A load equal to the WLL and correctly fitted to the clamp should be raised and then lowered onto the floor, within 5 seconds of which it must be raised again. With the load now suspended, if the clamp is fitted with a locking device, the locking device should be opened and the clamp should still hold the load. The locking device should then be closed and the load lowered onto the floor allowing the equipment to go slack. The load must not become detached during any part of the test.

Notes:

Manufacturers Tests

Type Verification

- Test to determine the coefficient of friction. This test is made on 3 samples which replicate the teeth of the clamp jaws against a test piece of material of the maximum hardness intended to be used with the clamp. A tensile force is then applied to the test arrangement
- Test to ensure the holding force acting on the load is at least 2 x the WLL
- Test to ensure the clamp is suitable for the minimum plate size specified. A test plate equal to the minimum plate size less the safety range, i.e. 10% up to 50mm plate size, 5mm for 50mm to 100mm plate size and 5% for plates over 100mm, must be lifted and held by the clamp

Manufacturing Tests and Examination

On completion of manufacture each plate clamp must be subject to:

- A static load test equal to 2 times the WLL $\pm 2\%$ held for a period of 1 minute. If the use of the clamp permits, or requires, the tilt or movement so that the lines of force through the attachment point vary, the test must be repeated at several positions through the movement to simulate the worst operational conditions. After removal of the load(s) there must be no deformation, cracks or other defects
- Thorough examination

Marking Requirements

EN 13155 requires plate lifting clamps to be permanently and legibly marked with the following minimum information:

- Name and address of the manufacturer
- Model identification
- Serial number (identification mark)
- Year of manufacture
- WLL
- The self-weight of the clamp if it exceeds 5% of the WLL or 50kg
- Mandatory marking (e.g. CE Marking where applicable)

Storage and Handling

All plate clamps other than those fixed permanently in position should, after use, be returned to safe storage. The general requirements are essentially that the storage area should be dry, free from injurious pollution and extremes of temperature, together with the following:

- Equipment returned to storage should be checked by a Responsible Person to ensure that it is in good order and that all parts of a clamp are present
- When being handled, clamps should not be dropped or thrown down

Pre-Use Inspection and Through Examination

In addition to the thorough examination necessary under statutory provisions, all plate clamps should be visually inspected by a Responsible Person prior to use or on a regular basis. The interval between inspections will depend on the conditions of service.

In-Service Inspection

If any of the following defects are present they should be withdrawn from service and referred to a Competent Person:

Types 1 and 2

- Blunted teeth in either fixed or moveable jaws. This point should be frequently checked as cam or wedge action may be affected
- Frame opened out
- Worn or bent pins
- Mechanism not working freely
- Wear on gripping surfaces
- Nicks, cracks, gouges or corrosion present

Additionally for type 1 only

- Broken or stretched spring in locking lever
- Unsatisfactory action of locking lever
- Tight, bent or damaged clamping threads

Thorough Examination

The definition of lifting equipment and lifting accessories used in LOLER make it clear that plate handling clamps fall under the heading of lifting accessories.

Unless a written scheme of examination, drawn up by a Competent Person, is in place and operating they must be thoroughly examined by a Competent Person at intervals not exceeding 6 months.

Reports of thorough examination should be retained and cross referenced to the clamp's historical records for inspection by the Competent Person or HSE.

The requirements for load tests to be made as part of the examination will vary dependent on the circumstances.

If a repair has been made, the manufacturer's instructions must be followed, however, in most other circumstances a load test will serve no purpose as the strength of the clamp is already known. Further, repetitive overloading of plate clamps will shorten their working life.

During the examination the following should be checked:

- General for all types of plate clamps; the general appearance and operation of the plate clamp. A functional test should be made to ensure the correct operation of the clamp, its levers and gripping mechanisms
- Mechanism and parts not working freely
- Worn, blunted, chipped or otherwise damaged teeth
- Frame and side plates opened out, bent or distorted
- Cracked welds
- Loose, worn or bent fixing pins, bolts etc.
- Nicks, cracks, gouges and similar mechanical damage or corrosion

Additionally in the case of clamps that have locking mechanisms:

- Broken, stretched, damaged or corroded spring mechanism
- Unsatisfactory action of the locking lever

The manufacturer's instructions will indicate the maximum allowances for wear etc., and must be followed at all times.

Examination Points:

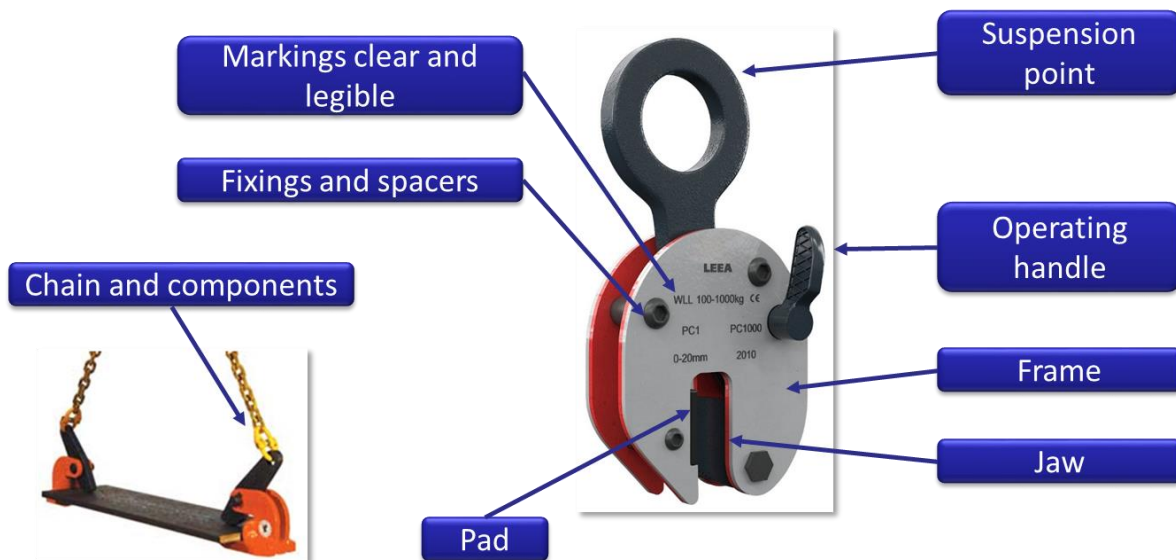

Safe Use of Plate Clamps

Clamps that grip the plate by friction to carry it vertically

- Clamps designed for use at an angle should always align with the sling. In all other cases the clamp must be at right angles to the edge of the plate. If this is not done the clamp will slip or twist causing possible damage to the jaw teeth and distorting the side plates
- If the plate to be lifted is long and tends to bend, two or more clamps should be used in conjunction with a spreader beam, otherwise the clamp may become distorted and drop the load
- The clamp should always be placed onto the plate as far as it will go. On cam operated clamps with a locking lever, if the plate is in the horizontal position and the cam is uppermost, operation of the locking lever may tend to force the clamp off the plate. This can damage the jaw teeth
- Never lift more than one plate in the clamp, place packing between the jaws of the clamp and the plate or lift a plate of harder material than for which the clamp has been designed as the plate will slip damaging the jaw teeth
- Clamps should not be used for lowering from vertical to horizontal or vice-versa unless designed to do so as this will bend the side plates, cause the plate to slip damaging the jaw teeth

Clamps that support the plate to carry it horizontally

- Always use clamps in the combination for which they have been designed, e.g. 2, 4 etc., and with the correct sling at the design angle of use. Failure to meet these requirements will alter the gripping action and forces imposed. This can lead to overloading, causing the toe plate to be bent, side plates may become damaged and ultimately the plate to be dropped
- Unless designed for the purpose, plate clamps should not be loaded at an angle to the side of the plate as this will twist and distort the side plates, twist the tongue and its fixing bolt and lead to cracked welds

Misuse:



Shock Loading

Information which should be exchanged between the user and the designer or supplier

Types 1 and 2

- Thickness or range of plates to be handled
- Longest length and greatest width of plate to be handled
- Maximum and minimum weight to be lifted
- Effective section of crane hook on which the clamp or clamp sling is to be used
- Whether the clamp is to be used to handle plates:
 - Horizontally only
 - Vertically only

- Horizontal to vertical through 90° only
- Horizontal to horizontal through 180°
- At an angle to the plane of the clamp side plates
- Material of plate and hardness if other than mild steel
- If the plate is polished
- If slight marking of the plate is any detriment
- Details of any adverse conditions e.g. handling hot plates, acidic environment
- The amount of headroom available
- Thickness of any spacers or packing in between plates when stacked which may limit access for the clamp
- Details of any additional tests required
- Any special operating instructions

Additionally for Type 2 Only

In addition to the above:

- Maximum number of plates to be lifted at one time
- If the clamps are to be supplied complete with sling or if not the type and length of sling to be used

Maintenance

Plate clamps have working parts which can become inoperative if not maintained. In addition to the inspection as above, therefore at appropriate intervals, plate clamps should be thoroughly cleaned and any moving parts lubricated, unless the manufacturer's instructions indicate otherwise. Particular care should however be taken with clamps having smooth jaws lined with friction material as lubricant on the jaws may be dangerous. Always ask the manufacturer for advice in such circumstances.

Note: Teeth must NOT be re-sharpened or re-cut unless specifically approved by the maker.



Training

Operative training should take the manufacturer's instructions for installation and use into account, paying particular attention to the following:

Due to the application for which the plate clamps are used, the operative may frequently be the person who selects the clamp. It is therefore recommended in such cases that all applicable information be available to the operative including this Code of Practice and the manufacturer's instructions.

Notes:

Clamps (Sometimes known as Tongs)



A Clamp is defined as equipment that is used to handle loads by clamping on a specific part of the load.

Note: Clamps are also known as tongs.

BS EN 13155: 2003 – Cranes – Safety – Non fixed load lifting attachments, is a Harmonised European standard and includes clamps of all kinds.

The manufacturer's or supplier's instructions should always be sought and followed.

Safety Requirements of BS EN 13155

Mechanical Strength

Withstand a static load of 2 times the WLL without any deformation taking place.

Withstand a static load of 3 times the WLL without release of the load even if permanent deformation takes occurs.

Marking

Each clamp should be permanently and legibly marked with the following minimum information:

- The business name and full address of the manufacturer and, where applicable, his authorised representative
- Designation of the machinery
- Serial number
- Weight of unloaded attachment, when it exceeds 5 % of the Working load limit of the equipment or 50 kg, whichever is the less
- The year of construction, that is the year in which the manufacturing process is completed
- Working load limit in tonnes or kg. When the attachment is used in several configurations, the resulting working load limits shall also be indicated
- Mandatory marking (e.g. CE Marking where applicable)

Additional Marking Requirements

Where applicable, the following additional information shall be stated:

- On an attachment which holds the load using clamping forces, the permissible gripping range
- On equipment connected mechanically to the load, indication on the connectors fitted on the load (e.g. connectors integrated in prefabricated concrete parts)

Handling

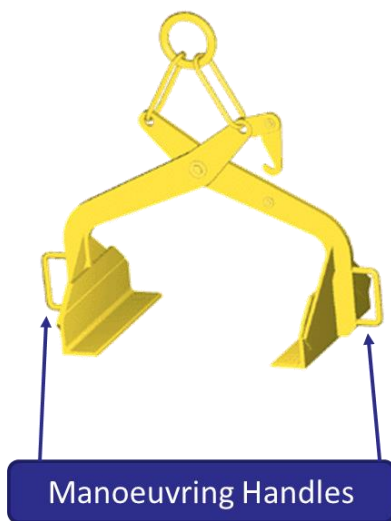

An attachment that is intended to be guided manually shall be equipped with handle(s), arranged so that finger injuries are avoided. Handles are not required if features have been built in to provide natural handholds.

Storage

When not required for use it shall be possible to set down the attachment so that it is stable during storage. To be regarded as stable it shall not tip over when tilted to an angle of 10° in any direction. This shall be achieved either by the shape of the attachment or by means of additional equipment such as a stand.



Clamp Holding Forces

- The holding force of clamps holding by friction to prevent the load from slipping shall be at least 2 times the working load limit
- In the case of clamps holding by friction, where the range of thickness does not start at 0, a safety range in which the holding force does not fall below the value given in clause 5.2.7.1 is required below the smallest specified thickness, in order to be able to compensate for the manufacturing tolerances, elastic deformation etc.

The following minimum safety ranges are required:

- For a minimum thickness less than or equal to 50 mm: 10 % of the minimum thickness
- For a minimum thickness between 50 and 100 mm: 5 mm of the minimum thickness
- For a minimum thickness more than 100 mm: 5 % of the minimum thickness

Note: Due to the wide variety of applications for clamps, it is impossible to specify a safety range which is suitable for all. The above ranges should therefore be treated with caution and increased as appropriate to the application

- In the case of clamps holding by friction, the clamping mechanism shall be designed to ensure that the clamping force will be maintained in case of deformation of the load (e.g. surface rusting and elastic and plastic deformation).

Note: This can be achieved by, for example, a scissor mechanism activated by gravity or by a pressure compensation device (e.g. springs, hydraulic accumulators) etc.

- Clamps holding the load hydraulically or pneumatically shall be fitted with a device to compensate for any pressure drop below working pressure
- Where the holding force of clamps holding by friction to prevent the load from slipping cannot be maintained at minimum of 2 x the working load limit, an acoustic or optical warning signal shall be automatically activated
- Clamps which are not self-closing the releasing of the load shall be actuated by a two action control but this is not necessary, if the release of the load is not possible until the load has not been put down or in no-go areas

Other Safety Features

(1) Clamps to be used in a building area shall have a positive holding device or a secondary positive holding device (e.g. slings, net, cage)

(2) The positive holding device or secondary positive holding device shall prevent the release of the complete load or any loose parts of the load

(3) For handling loose materials (e.g. bricks and tiles) the positive holding device or secondary positive holding device (e.g. nets or cages) shall not have side and bottom openings of more than 50 mm². For handling loose materials (e.g. bricks and tiles) the positive holding device or secondary positive holding device (e.g. nets or cages) shall be capable of holding a uniformly distributed load equal to 50% of the WLL in all four horizontal directions and 200% of the WLL in the vertical direction.

Note: It is recommended that the secondary positive holding device is automatically activated

The requirements stated above (1), (2) and (3) shall not apply, if the clamp is intended to be used only to lift the lowest part of the clamp to a height less than 1.8 m and is either:

- For moving single bricks or building components with a weight less than 50 kg, or,
- For unloading lorries to the ground

In-Service Inspection

In addition to the thorough examination required under LOLER, all clamps should be visually inspected by a responsible person prior to use or on a regular basis taking into account the conditions of service.

This inspection should include an operational check of all functions of the clamp and a visual check for mechanical damage. If any of the following faults are present, the clamp should be withdrawn from service and referred to a competent person:

- General damage to the body such as distortion, bending etc.
- Damage to the lifting eye or other means of suspension
- Damage to the lifting plates/grab faces
- Failure or dysfunction of any pivoting components
- Missing or illegible markings, model, manufacturer, serial number, load rating information etc.

Thorough Examination

The definition of lifting equipment used in LOLER includes its attachments used for anchoring, fixing or supporting it'. However, it is the opinion of LEEA that although beam clamps fit this definition their nature and use, particularly those designed for temporary applications, is akin to lifting accessories. It is therefore recommended that they be included in the examination regime as lifting accessories. Unless a written scheme of examination, drawn up by a Competent Person, is in place and operating they should be thoroughly examined by a Competent Person at intervals not exceeding 6 months. Reports of thorough examination should be retained and cross referenced to the equipment's historical records for inspection by the Competent Person or HSE.

For some applications it may also be necessary to have the installation thoroughly examined by a Competent Person before the beam clamp is put into service.

Following repair, beam clamps must be re-verified by a Competent Person. The report of the verification should be retained and cross referenced to the clamps historical records for inspection by the Competent Person or HSE.

The general appearance of the clamp, should be considered during the examination, in particular paying attention to the following:

- Bending and distortion, mechanical/physical damage and corrosion of the body. In particular attention must be paid to hollow sections which may have dents or localised buckling and to the flanges of structural rolled steel sections. Hollow sections need great care when looking for signs of corrosion as this may be internal
- Fixings and welds. Welds and adjacent areas should be examined for cracks, bolts and rivets examined for wear, distortion, corrosion, damage and tightness
- Lifting eyes, load attachment points etc. looking for wear, distortion, elongation of eyes and other physical damage
- Other lifting accessories that form a part of the clamp, e.g. shackles or slings, or which are used in association with the clamp, must be included as a part of the examination

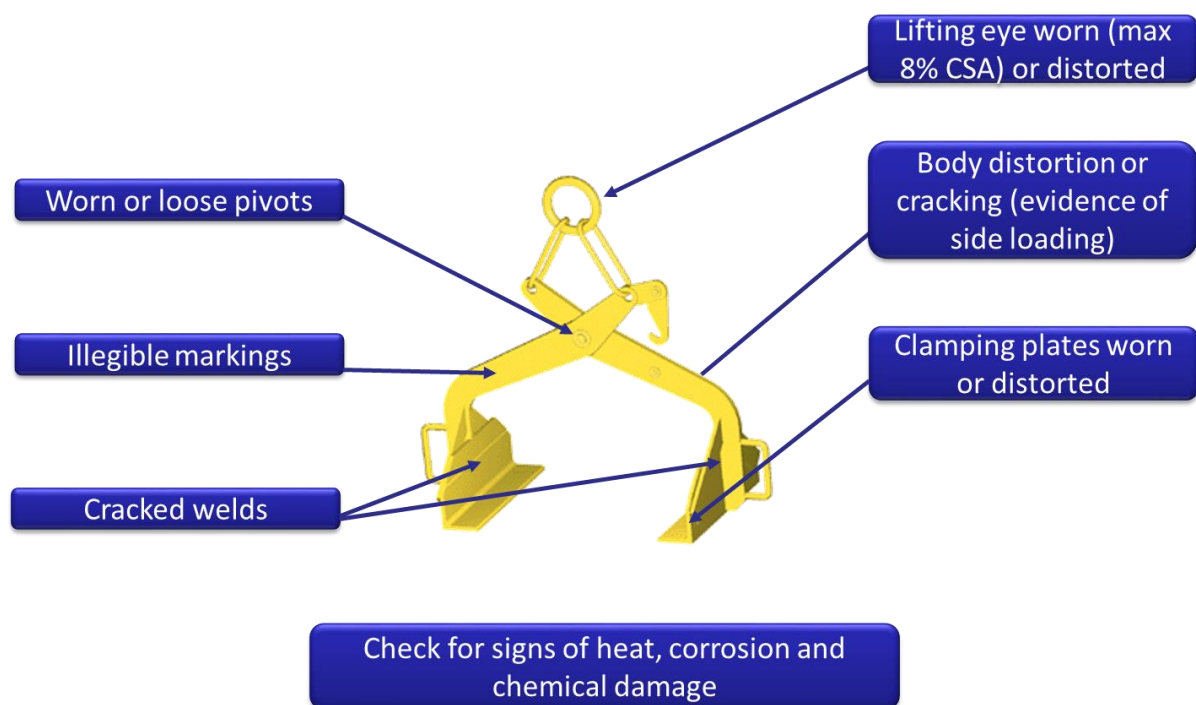

Notes:

Maintenance

Clamps usually need little or no routine maintenance other than keeping them clean and dry since the working parts are essentially very simple. Specific maintenance instructions issued by the manufacturer should be followed.



Information which should be exchanged between the user and the designer or supplier

Instruction Handbook

To allow purchasers to safely select, install, use and maintain removable lifting equipment during its normal lifetime, the manufacturer shall at least provide the following information and guidance in an instruction handbook, specific to the equipment supplied:

- Brief description
- WLL
- Intended use
- Characteristics of the load including the performance and the number of parts that can be handled at one time
- Determination of the operating range
- Instructions for use and operation
- Fitting, securing, coupling/uncoupling and adjustment of the equipment on the lifting appliance
- Handling and storage
- Stability
- The range of temperature within which the equipment can be operated
- Restriction of operation in special atmospheres (e.g. high humidity, explosive, saline, acid or alkaline environments)
- Restriction for handling dangerous goods
- Where appropriate, prohibition of handling above people
- Specific training for operators

Specific Information

In addition to general information for the safe use of clamps, the following specific information should be supplied by the manufacturer:

- Surface condition (e.g. grease, paint or other coatings) of the part to be handled
- Clamping ranges to be observed
- Surface hardness of parts to be handled
- Measures to prevent unintentional release of the load due to the weight of the crane hook, bottom block or connections acting on the clamp (e.g. a length of chain)

Operative Training

Operative training should take the manufacturer's instructions for use into account, paying particular attention to the following:

Due to the application for which the clamps are used, the operative may frequently be the person who selects and affixes the clamp. It is therefore recommended in such cases that all applicable information be available to the operative including this Code of Practice and the manufacturer's instructions. Operatives whose job it is to affix clamps should be trained in the correct method of assembly and fitting the clamp

Notes:

Lifting Beams

This section covers lifting beams, spreader beams and lifting frames that are usually designed either for a specific purpose or as general purpose beams for a specified range of lifts.

They are within the scope of BS EN 13155: 2003 + A2: 2009, Cranes – Safety – Non-fixed load lifting attachments. Prior to this standard there was not a British Standard dealing specifically with lifting beams etc. so the designer and manufacturer of this type of equipment was likely to have worked to the requirements of the relevant standards for weldable structural steels, wrought steels for mechanical and allied engineering purposes and to the following:

- BS 449 The use of structural steel in building (now superseded by Euro codes)
- BS 2573 Permissible stresses in cranes

The section will cover beams, spreaders and frames which are attached to the load suspension point of a lifting machine or crane and can therefore be considered to be portable. **It is not intended to cover beams which are permanently attached to a crane in place of a bottom block or patent lifting frames used in the handling of cargo containers.**

Principles for Selection

Application of Lifting Beams, Spreaders and Frames

Lifting beams etc. are used for various purposes as detailed below:

- To reduce the headroom required when lifting long loads
- To provide multiple lifting points
- To provide a means of handling out of balance loads
- To provide a vertical lift with controlled or no inward pull for:
 - Eyebolts and similar lifting points
 - Loads which must be protected from crushing forces
- To provide a means of handling loads requiring special attachments such as hooks, plate clamps, etc.
- To provide a means of using two cranes in tandem
- To provide lifting points at adjustable centres

Beam Weight

The weight of the lifting beam, spreader or frame, together with its associated lifting accessories, must be added to the weight of the load when assessing the total load imposed on the crane hook.

Lifting Accessories

Many lifting beams and spreaders are fitted with standard lifting accessories such as shackles, wire rope slings, chain slings, web slings, plate clamps, turnbuckles, etc. The requirements of the individual sections of the LEEA COPSULE apply whether these items are readily removable from the beam or not. Whilst removable lifting accessories can be used for separate lifting applications, it is good practice to keep them together as if forming an integral part of the lifting beam. This is particularly the case if they are recorded with the beam on the EC Declaration of Conformity, report of thorough examination etc.

In the case of lifting accessories used separately, the onus is on the user to replace or reassemble these onto the beam. Care should also be taken to ensure that the component has in fact been thoroughly examined in accordance with current legal requirements and the relevant section of the LEEA COPSULE before using it for a different lifting application.

Suspension Point

The suspension point is that part of the beam etc. by which it is attached to the crane hook or other lifting device.

Load Attachment Point

The load attachment point is that part of the beam etc. to which the load is attached.

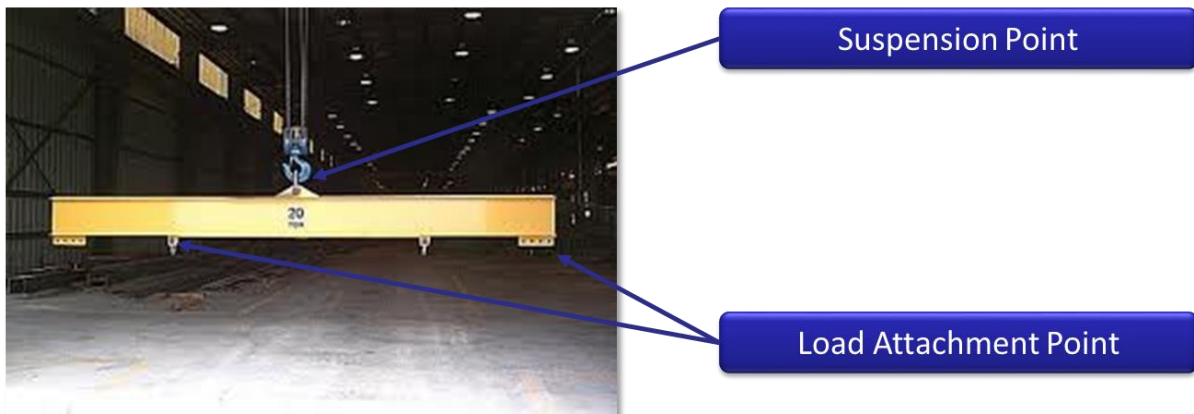

Notes:

Types of Lifting Beam, Spreader Beam and Lifting Frames

Lifting Beam

The types of lifting beam are diagrammatically represented in figures below. Note that the suspension points are shown as being vertically below the crane hook. Although single suspension points are shown, multiple suspension points for use with two or more crane hooks can be provided, as can multiple load attachment points.

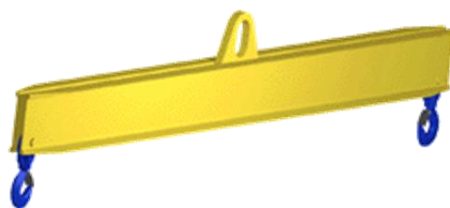
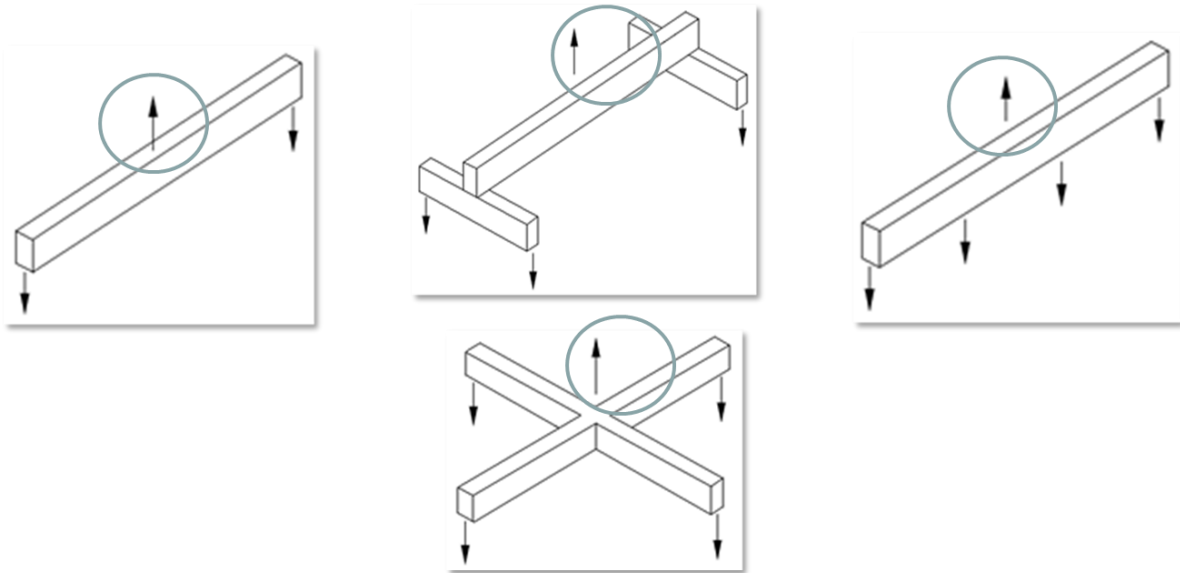

Combination Spreader Beams



Modular Spreader Beam

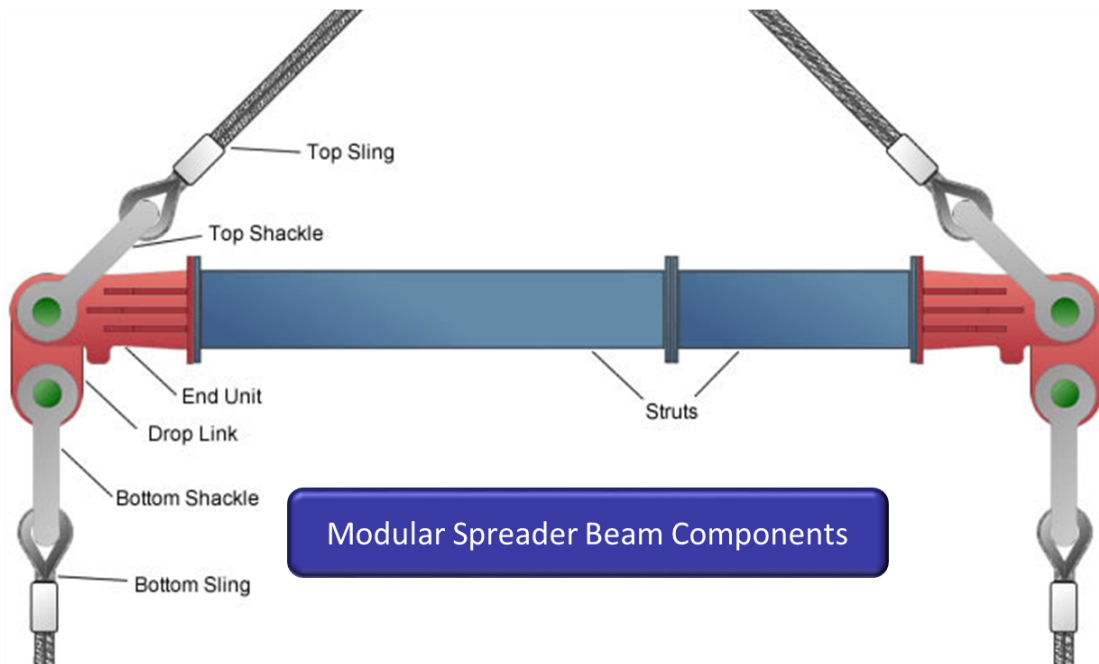

Lifting Frame

A lifting frame is diagrammatically represented in figure below, which is in effect a combination of four spreaders.

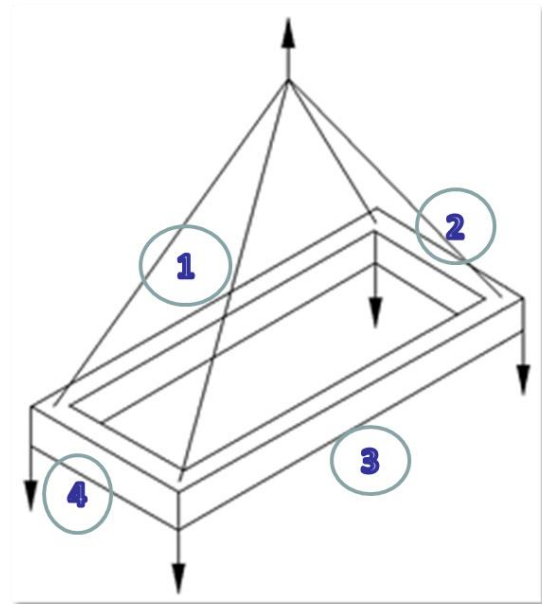

Combination Lifting Beams

If headroom is restricted, a combination of spreader and lifting beam is necessary.

In this case there will be bending in the overhanging ends (like a cantilever).

The maximum **bending** stress will occur at each cantilever end of the beam when under load.

The maximum **compressive** stress will be at the centre of the lower flange of the beam.

The maximum **tensile** stress will occur at the centre of the top of the beam between the top sling connection points.

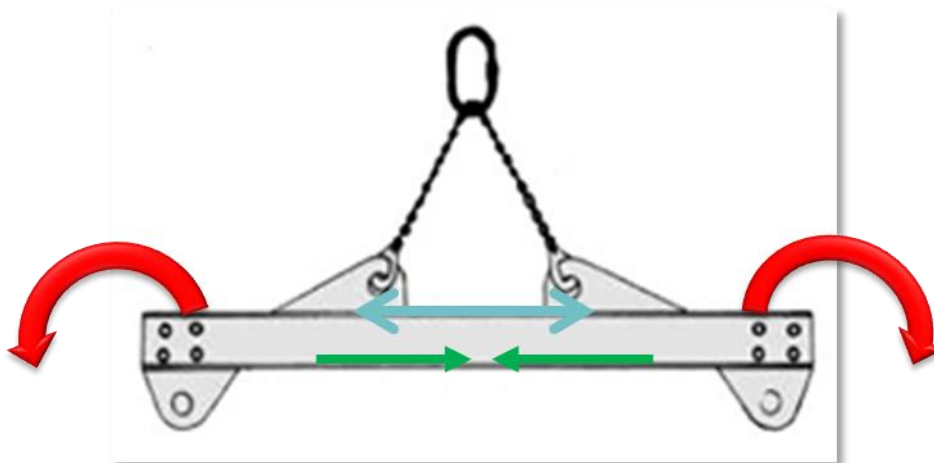

Safety Requirements of EN 13155

Mechanical Strength

Withstand a static load of 2 times the WLL without any deformation taking place.

Withstand a static load of 3 times the WLL without release of the load even if permanent deformation takes occurs.

Adjustable Lifting points

If the lifting beam is constructed with movable lifting points to allow for adjustment, the lifting points must be captive and lockable on the beam to prevent them falling off during the lift.

Tilt

If designed to tilt the maximum angle of tilt to the horizontal must be clearly indicated.

If not intended to tilt it must be designed to tolerate a tilt of 6° to the horizontal.

Marking

The following information shall be permanently and legibly marked with the following minimum information:

- Name and address of the manufacturer
- Model identification
- Serial number (identification mark)
- Year of manufacture
- WLL
- The self-weight of the beam if it exceeds 5% of the WLL or 50kg

Notes:

Storage and Handling

When not in use, lifting beams should be stored in a proper manner to prevent damage. The general requirements are as in section 1 of the LEEA COPSULE, i.e. the storage area should be dry, free from injurious pollution and extremes of temperature, together with the following:

- Special stands or packing should be provided to support the beam if it will not stand on its own
- **Particular attention should be paid to beams that are designed to be dismantled for transportation and storage. Whilst in storage, the component parts should be positively identified and kept together. Only the manufacturer's component parts or parts manufactured to the same specification should be used in reassembly. There are certain cases where re-verification, e.g. a test and examination, may be required on reassembly and advice must be sought from the manufacturer or other competent authority on this point**
- A lifting beam fitted to a crane hook without the load attached is a load in its own right and all the rules governing operation of a crane or hoist with a load attached must be observed. In certain cases, a lifting beam suspended without the load may be very unwieldy and care must be taken in handling the beam on its own. This applies particularly to low headroom lifting beams

In-Service Inspection

In addition to the thorough examination necessary under statutory provisions, all lifting beams should be visually inspected by a Responsible Person prior to use or on a regular basis. The interval between inspections will depend on the conditions of service. If any of the following defects are present they should be withdrawn from service and referred to a Competent Person:

- Lifting eyes, bows, bolts, etc., should be inspected for obvious signs of wear, distortion and physical damage
- Load attachment points such as hooks fabricated into the beam should be inspected for wear, distortion and physical damage
- Attachment points for shackles used for lifting the beam or attaching the load should be inspected for wear and elongation of holes. It is usually necessary to remove the shackle to do this
- Bolted connections to the beam should be checked for tightness
- The beam should be checked for distortion
- The beam should be checked for localised physical damage. Particular attention should be given to hollow sections which may have dents or localised buckling and to the flanges of structural steel sections
- Corrosion damage

- Signs of cracks and distortion especially in welded details
- Ensure that requisite markings are clearly visible and correspond to the loadings stated on the documentation
- Lifting accessories, such as shackles, eyebolts, wire rope slings, chain slings, synthetic web slings, plate clamps, hooks, turnbuckles etc. should all be inspected in accordance with the respective sections of the LEEA COPSULE

Note:

If the equipment is damaged, advice should be sought from a Competent Person. Repairs should only be carried out by competent manufacturers or under the supervision of a Competent Person.

Thorough Examination

The definition of lifting equipment and accessories used in LOLER make it clear that the lifting beams, spreaders and frames covered in the scope of this section of the code fall under the definition of lifting accessories. Unless a written scheme of examination, drawn up by a Competent Person, is in place and operating they must be thoroughly examined by a Competent Person at intervals not exceeding 6 months. Reports of thorough examination should be retained and cross referenced to the equipment's historical records for inspection by the Competent Person or HSE.

Following a repair, lifting beams, spreaders and frames must be re-verified by a Competent Person. In the case of structural repairs, the verification will usually be by way of a proof test and thorough examination. The report of the verification should be retained and cross referenced to the equipment's historical records for inspection by the Competent Person or HSE.

In the case of the replacement of lifting accessories with components which are identical in every respect, the initial documentation for the replacements should be retained and cross referenced to the equipment's historical records for inspection by the Competent Person or HSE.

The requirements for load tests to be made as part of the examination will vary dependent on the circumstances. If a structural repair has been made a load test may be deemed necessary, but great care will be needed to ensure that any load is applied correctly so as not to damage the beam. We should also bear in mind that in most circumstances a load test will serve no purpose as the strength of the lifting beam is already known.

Note: Further, repetitive overloading of lifting beams will shorten their working life. We will therefore consider load testing lifting beams once we have considered the general requirements for the examination.

<p>Notes:</p>

The general appearance of the beam, should be considered during the examination, in particular paying attention to the following:

- Bending and distortion, mechanical/physical damage and corrosion of the structural members. In particular attention must be paid to hollow sections which may have dents or localised buckling and to the flanges of structural rolled steel sections. Hollow sections need great care when looking for signs of corrosion as this may be internal
- Fixings and welds. Welds and adjacent areas should be examined for cracks, bolts and rivets examined for wear, distortion, corrosion, damage and tightness
- Lifting eyes, load attachment points etc. looking for wear, distortion, elongation of eyes and other physical damage
- Other lifting accessories that form a part of the lifting beam, or which are used in association with the beam, must be included as a part of the examination

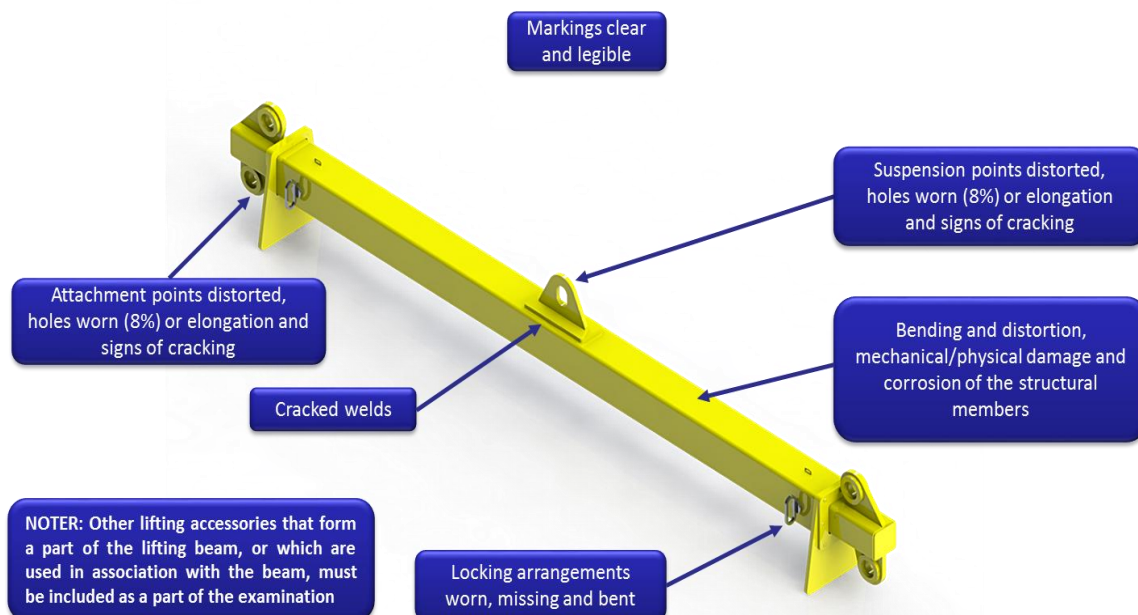

Manufacturers Documentation

It is not uncommon for users to manufacture, or have manufactured to their specifications and drawings, lifting beams, spreaders and frames which they then send to a lifting equipment company for test and examination.

Under older legislation, the company making the verification would have issued a test certificate, which allowed the item to enter service.

Under current legislation this is no longer the case and it is the user who is the responsible person (legal) with the duty to affix the CE mark and issue the EC Declaration of Conformity to allow the item to enter service. The testing organisation will only issue a report of a test to the responsible person (legal) for retention in their technical file.

Information which should be exchanged between the user and the designer or supplier

The following is the minimum amount of information which should be exchanged between the user and designer or supplier of a lifting beam, spreader or frame:

- The reason for using a lifting beam instead of other methods of handling the load
- The total maximum weight of the load to be lifted together with any other forces which may be superimposed on the load
- A detailed description or drawing of the load to be lifted together with principal dimensions which affect the lifting operation including information on the position of the centre of gravity and available headroom
- Details of external obstructions to the use of the beam or spreader. Attention is drawn to the fact that a lifting beam could foul the structure of a double beam crane before the upper limit is reached
- The exact type, dimensions and capacity of the crane hook and safe working load of the crane. Particular attention should be paid to the safety catch fittings and guards
- The speed and duty rating of the crane
- Frequency of use
- Environmental considerations such as extremes of temperature or corrosive atmospheres
- The level of operatives' skill and ergonomic considerations. It should be made clear if the beam is to be used by unskilled labour or if the design of the lifting operation requires the attention of a skilled fitter. If manipulation of the beam is necessary in order to carry out the lift then the labour availability and requirements should be specified
- Operating assembly and storage instructions
- Any additional tests required by the purchaser
- The weight of the lifting beam

Notes:

Safe Use of Lifting Beams, Spreader Beams and Lifting Frames

In addition to any specific instructions relating to the safe use of the lifting beam issued by the manufacturer, the following points should be observed. Reference should also be made to the individual sections of this code for the safe use of loose and detachable lifting accessories.

- Most lifting beams and spreaders are designed for a specific purpose and should not be used for other purposes without reference to a Competent Person
- Lifting beams and spreaders with lifting points designed for a particular crane hook size should always be used on the specified hook. Failure to do so can cause damage to both the hook and the lifting point
- When using a lifting beam designed for operating with two cranes in tandem, the rules for reducing the lifting capacities of the cranes must be observed. See BS 7121: Part 1: 1989
- The use of 'tag lines' is essential when manipulating long loads on a beam with a single suspension point. The tag lines should be of adequate length so that the personnel controlling the load can stand well clear of it. Tag lines must not be used to attempt to balance the load
- The lifting beam should remain in its intended attitude during use
- Lifting beams with multiple attachment points need particular attention to ensure that the safe working load on the individual point is not exceeded
- When lifting or setting the load down, care should be taken to ensure that individual load attachment points are not overloaded
- The lifting beam should not be allowed to foul the underside of the crane structure. If this is possible then consideration should be given to adjusting the limit switch of the crane to a lower position
- The weight of the beam must be added to the weight of the load when assessing the overall load on the crane hook
- When using beams with adjustable lifting centres, particular care must be taken to ensure that the manufacturer's specified loadings for the centres chosen are not exceeded

Training

Operator training should take the manufacturer's instructions into account, paying particular attention to the following:

Operatives and drivers should be informed of the specific uses for which the beam or spreader is intended. They should be shown the correct method of attaching the beam or spreader to the crane hook and the correct method of attaching the load to the beam or spreader.

In the case of beams which are dismantled for transportation and storage, operatives should be shown the correct method of assembling the beam or spreader.

Lifting Magnets

This section covers magnetic lifters which are within the scope of BS EN 13155: 2003 + A2: 2008, Cranes – Safety – Non-fixed load lifting attachments. There are four different types as follows:

- Battery-fed electric lifting magnets
- Mains-fed electric lifting magnets
- Permanent lifting magnets
- Electro-permanent lifting magnets

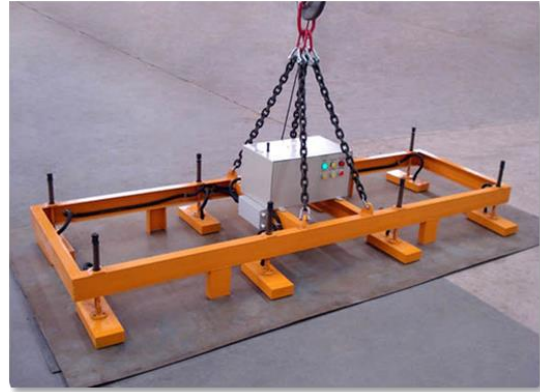

Principles for Selection

Applications

Magnetic lifters can be suitable for a variety of applications. Some may be used as general purpose lifting accessories, and therefore require their capacity to be assessed for each application, whereas others may be dedicated to a single application and are selected specifically for it. However not every load with ferromagnetic properties can safely be handled with a magnetic lifter.

The magnetic lifter selected must match the characteristics of the load. As well as the weight, this includes the shape, surface finish and magnetic properties of the load.

The shape of the magnet should be compatible with that of the load. For example a magnet with a flat face can handle sheet material whereas for lifting round section material, a magnet with a V shaped recess in the face is more suitable. For long loads, an arrangement of several magnets used in conjunction with a lifting beam is generally suitable as it provides the load with adequate support along its length. The position and capacity of the individual magnets should be such as to ensure that the share of the load imposed on each does not exceed its working load limit. For flexible loads, the positioning should provide support at short enough spaces to prevent the load from peeling off the magnet.

Notes:



Lifting magnets are normally rated for lifting a horizontal load in the vertical plane only. If the line of pull is not at right angles to the plane of the load, their lifting capacity will be substantially reduced and slippage may occur. For such applications, the advice of the manufacturer should be obtained.

General

Consideration should be given to the following:

- Lifting capacity required
- Characteristics of the load in terms of shape, surface finish and porosity
- Lifting machine it is to be used with
- Available headroom
- Self-weight of the vacuum lifter and degree of portability required
- Whether self-actuating or powered type required
- For powered lifters, whether battery or mains power required
- For venture types, the pressure, volume and quality of air required
- Method of control and control features required
- Proximity of persons during operations
- Back up and other safety features required
- The documentation required by legislation (EC Declaration of Conformity or Report of Thorough Examination as appropriate). If this is not on record, refer the vacuum lifter to a Competent Person for thorough examination

Notes:

Magnetic Lifters

Although some manufacturers offer a standard range of magnetic lifters, unlike other lifting equipment, they are not usually regarded as “general purpose” equipment.

Magnetic lifters are usually employed in specific circumstances to lift specific loads. As there is no positive connection between the lifting device and the load, the ability of the magnetic lifter to safely lift a particular load needs to be carefully considered. This will normally involve tests to determine the lifting power of the magnet on the specific load.

Magnets will only work on a magnetic material which usually means a ferrous metal although some other materials such as cobalt or nickel are capable of being lifted magnetically.

Due to the specialized nature of magnetic lifting applications, the advice given in this unit can only be of a general nature and should be augmented by the specialist advice provided by the manufacturer or supplier of the magnetic lifter.

Terminology

Ferro-Magnetic Material

A Ferro-Magnetic material is one which behaves like iron under the influence of a magnet, that is, it is attracted by the magnetic field. Some examples are cast iron and carbon steels.

Magnetic Field

The “field” of a magnet is the space beyond the physical boundaries of the magnet where the effects of magnetism can be detected.

Magnetic Flux

Magnetic flux is a measure of the quantity of magnetism taking account of the strength and extent of the magnetic field. As such it is a measure of the “power” of a magnet.

Magnetic Poles

Magnetic poles are at the ends of a magnet and are the points at which the magnetic field is concentrated.

Permanent Magnet

A magnet that is permanently magnetised and does not depend upon an electric current.

Electro-Permanent Magnet

A magnet where an electric current is used to switch the polarity of the magnetic material. There are no moving parts and the electric current is only required to create the magnet, not to sustain it.

Electro Magnets

If an electrical current is passed through a wire it will produce a magnetic field around that wire which will exist whilst the current flows. In most cases when the current is switched off the magnetic field will collapse. The strength of the magnetic field can be intensified by forming the wire into a coil containing a core made of magnetic material. The core will display the properties of a magnet for as long as current flows through the wire. The power can be supplied to an electro-magnet lifter from the mains electricity or from built in rechargeable batteries. Electro magnet lifters can vary from small portable units to large multi-head units integrated into the crane.

Battery Powered Magnetic Lifters

Battery fed electric lifting magnets should provide a tear-off force corresponding to at least 2 times the working load limit under the conditions specified by the manufacturer.

There should also be an indicator to show if the magnet is switched on or off.

An automatic warning device should be provided which monitors the power supply and provides a warning at least 10 minutes before the supply reaches the level where the load will be released.

The warning device can either be optical or audible.

There should also be a safety device which, in the event that the low power warning is activated, prevents the magnet from being switched on again until the battery is recharged to the minimum level at which the low power warning is not activated.

Mains Electricity Powered Magnetic Lifters

Mains fed electric magnets should also provide a tear-off force corresponding to at least 2 times the working load limit working under the conditions specified by the manufacturer.

There should be an indicator to show if the magnet is switched on or off and, for magnets with variable power, to distinguish between full and partial magnetism.

An optical or audible warning device should be fitted to indicate mains power supply failure.

A stand-by battery should be fitted to supply power to the magnet in case of mains failure. The battery should be capable of supplying enough power to hold the working load limit for at least 10 minutes.

The warning device and stand-by battery are not necessary if the unit is working in a 'no go' area or if the maximum height of lift at the magnet is restricted to 1.8m and the load is less than 20kg.

Magnets lifting loads such as plates, sheets or bars from the top of a stack, should have controls to allow the operator to reduce the power to shed any excess load and restore full power when the excess has been removed.

Permanent Magnets

Some substances are naturally magnetic and others are capable of being “magnetized” and retaining that magnetism. The most common form of permanent magnet is a substance called Magnetite and this is used for domestic applications. Industrial permanent magnets use “rare earth” substances such as Samarium or Neodymium which produce very much stronger magnetic fields. An industrial permanent magnet is switched “on and off” by mechanically rotating a moveable magnet or magnets within the device thereby arranging it to add to or cancel out the field of the static magnets.

Most permanent magnet lifter are switched manually by means of a lever but some manufacturers offer the option of electrical or pneumatic powered mechanisms.

This type of magnetic lifter shall provide a tear off force at least three times the working load limit under the conditions specified by the manufacturer. The controls shall clearly indicate whether the magnet is on or off.

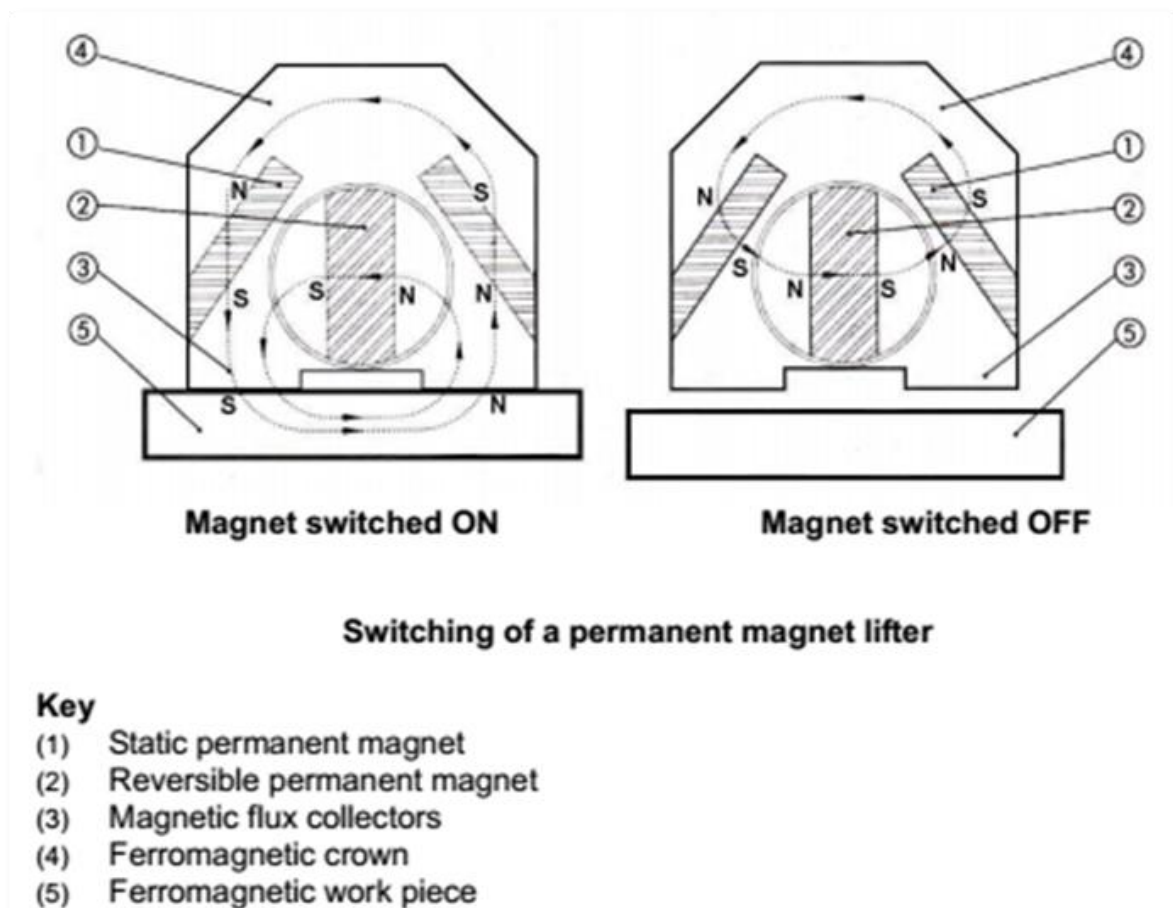

Methods of Attachment

Portable magnets are generally of the permanent or electro-permanent type with a lifting capacity up to approximately 3 tonnes or of the battery type with a lifting capacity up to up to approximately 5 tonnes. They will usually be fitted with a lifting eye to facilitate easy connection to the lifting machine hook. Higher capacity magnets of the electro-permanent or electro type are often an integral part of the lifting machine.

Multiple magnets of all types may be used with advantage in conjunction with a lifting beam or spreader to lift long and/or flexible loads.

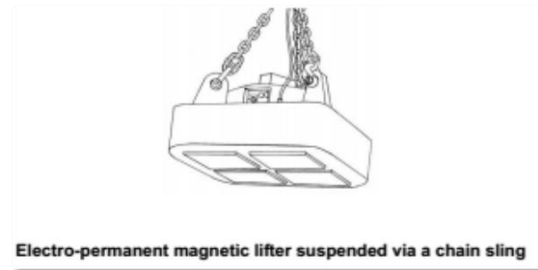
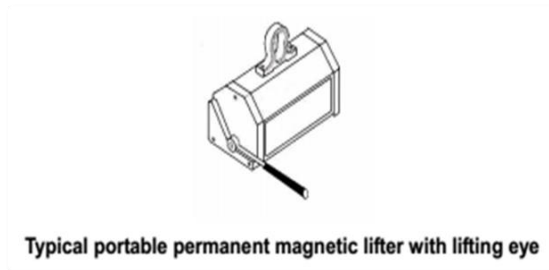

Safety Requirements – Exposing People to Danger

In the case of electro-magnets, the magnetic forces are only generated when the electrical supply is flowing.

Failure of the electrical supply will cause the magnet to lose its lifting power instantaneously.

Without additional safety features, their use is therefore limited to situations where a risk assessment has established that falling loads do not present a hazard to people.

The warning devices and stand-by battery referred to above are intended to allow time for persons to leave the danger zone.

In applications where it may be difficult to leave the danger zone within a safe period of time, further measures will be required. These may include a redundancy of the supply lines and control systems or a secondary mechanical holding system which can be deployed before exposing persons to danger.

Notes:

Marking

The following information should be permanently and legibly marked on a suitable part of the magnetic lifter unless the magnetic lifter is a permanently installed component of a larger lifting appliance in which case the appliance itself may be so marked:

- (1) Identification mark
- (2) CE mark
- (3) Working load limit
- (4) Name of manufacturer
- (5) Year of manufacture
- (6) Load rating information relating to thickness of load, air gaps etc.
- (7) Self weight of the magnet if it exceeds 5% of its WLL or 50 kg whichever is the less

Storage and Handling

When not in use, portable magnetic lifters should be returned to proper storage. It is additionally recommended that:

- They are stored in clean, dry conditions which are free from injurious pollution or extremes of temperature. In particular it must be dry. Neodymium, used in most permanent magnets is extremely susceptible to corrosion
- They are stored off the ground and away from potential sources of damage. It must be borne in mind that they can be heavy
- Equipment that is returned to stores in dirty condition should be cleaned and dried. Powerful solvents or cleaning agents should not be used and neither should direct heat. Surfaces liable to corrosion should be lightly oiled or otherwise protected e.g. the face of the magnet
- When a magnetic lifter has been in storage and is to be taken into use, it should be checked by a responsible person for any signs of damage or deterioration before use. Any problems found should be reported to a competent person for resolution

Notes:

In-Service Inspection

In addition to the thorough examination required under LOLER, all magnetic lifters should be visually inspected by a responsible person prior to use or on a regular basis taking into account the conditions of service.

This inspection should include an operational check of all the controls and indicators of the magnetic lifter and a visual check for mechanical damage. For battery operated models it is also necessary to check the condition of the battery and its state of charge.

If any of the following faults are present the magnetic lifter should be withdrawn from service and referred to a competent person:

- General damage to the body of the magnetic lifter
- Damage to the lifting eye or other means of suspension
- Damage to the magnet face
- Failure or dysfunction of any operating controls, warning indicators or other warning devices
- Missing or illegible markings, model, manufacturer, serial number, load rating information etc.

Information which should be exchanged between the user and the designer or supplier

It is strongly recommended that as much detail as possible about the application(s) is given to the manufacturer or supplier. If the magnetic lifter is for a specific application, it is usually possible to provide precise details of the task to be performed. For general purpose use such as handling a variety of steel stock in a machine shop, the information may have to be restricted to a selection of typical examples. The information should include but is not necessarily limited to the following:

- Mass of the load to be lifted
- Material of the load to be lifted, e.g. grade of steel, and the surface finish
- Shape and dimensions of the load to be lifted
- The structure of the load to be lifted e.g. a single slab, bundle or multiple sheets
- Details of the lifting operation including, height, travel and whether load shedding is required
- Characteristics of the lifting machine including the hoisting speed, travel speeds and headroom

- Method of connection to the lifting machine
- Availability of electrical supply if appropriate
- The control mechanism required, i.e. manual, power, integrated or remote
- The control features required e.g. load shedding
- Backup and other safety features required
- Details of the operating environment and service conditions e.g. extremes of temperature, probability of shock loading, uncertainty of mass of the load, whether persons can quickly leave the danger zone

Thorough Examination

The definitions of lifting equipment and accessories used in The Supply of Machinery (Safety) Regulations make it clear that a device used to connect a load to a lifting appliance is a lifting accessory and should be supplied with an EC Declaration of Conformity.

A magnetic lifter is therefore a lifting accessory and the Lifting Operations and Lifting Equipment Regulations state that they must be examined by a competent person at intervals not exceeding 6 months.

The EC Declaration of Conformity and the Reports of Thorough Examination should be retained and cross referenced to the magnetic lifter's historical records for inspection by the Competent Person or HSE.

For some applications it may also be necessary to have the installation thoroughly examined by a Competent Person before the magnetic lifter is put into service. This may be necessary in order to ensure that the operation of the lifter in practice complies with the theoretical prediction.

Following repair, magnetic lifters must be re-verified by a competent person. The record of the repair and report of verification should be retained and cross referenced to the lifter's historical records for inspection by the Competent Person or HSE.

Notes:

The manufacturer's instructions for the regular inspection and maintenance of the magnetic equipment should be followed. Where appropriate, inspection and maintenance schedules should include:

- Power cables to the magnet - check for damage and ensure that they are properly supported
- Magnet assembly - check for damage to the suspension points and that retaining bolts are kept tight
- Magnet face – check for any damage to the face which might affect performance
- Magnet - check for deterioration of insulation resistance; check the value of coil resistance to ensure that "inter-turn" faults have not developed whilst in use
- Electrical plug and socket connectors - check that mechanical strength, insulation and electrical conductivity are being maintained
- Lifting accessories e.g. chains, links etc associated with the magnet - thoroughly examine at appropriate intervals
- Electrical back-up batteries - check their condition and that the battery back-up alarm works when the power is off
- Control boxes/pendants – check for damage, legibility of control labels, correct function of controls including audible and visible warning devices
- Magnetic adhesion – periodic verification by inserting a ‘test piece’ of non-metallic material between the magnet and the material. It should still be possible to pick up the load with the test piece inserted

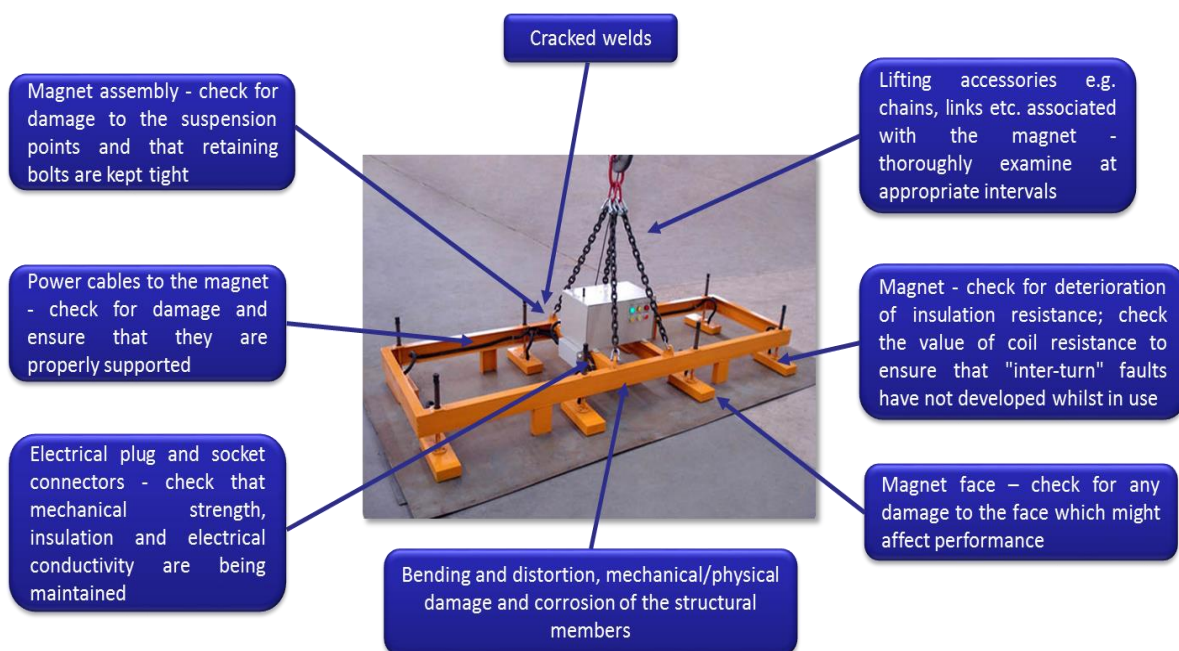

Control boxes/pendants – check for damage, legibility of control labels, correct function of controls including audible and visible warning devices.

Magnetic adhesion – periodic verification by inserting a 'test piece' of non-metallic material between the magnet and the material. It should still be possible to pick up the load with the test piece inserted.

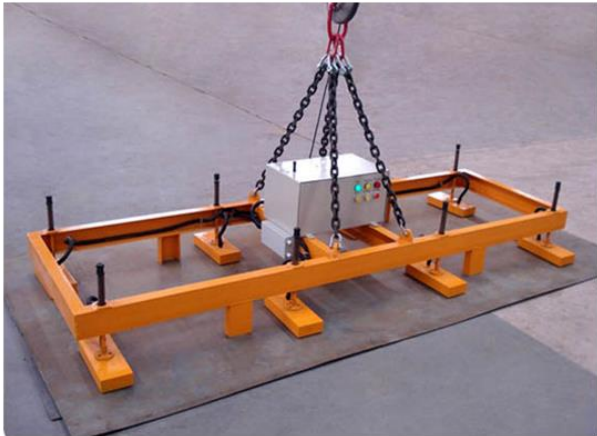

Electrical back-up batteries - check their condition and that the battery back-up alarm works when the power is off.

Safe working procedures should be devised for the safe isolation of the electrical supply (including any batteries) and followed by appropriate personnel.

Maintenance

Magnetic lifters usually need little or no routine maintenance other than keeping them clean and dry since the working parts are contained within a substantial steel shell and any working mechanism is essentially very simple. Specific maintenance instructions issued by the manufacturer should be followed. The condition of all batteries must be checked on a regular basis. The state of charge of stand-by batteries used with mains fed electro lifting magnets should be regularly checked. The battery for battery fed electric lifting magnets must be charged on a regular basis.

Safe Use of Magnetic Lifters

In addition to any specific instructions relating to safe use of the magnetic lifter issued by the manufacturer, the following points should be observed:

- Do not use to lift people
- Do not lift loads over people who are in the danger zone unless the magnetic lifter has the features needed to address this situation. These features can include a redundancy of critical supply cables and controls or a secondary mechanical means of securing the load. When

establishing the danger zone, take account of the nature of the load. For example, sheet material can fly a considerable distance to the side. If necessary establish a 'no go' area

- Only use the magnetic lifter for applications for which it has been specified or is otherwise suitable
- Ensure that the load is of sufficient thickness to absorb the full magnetic flux of the magnet otherwise the lifting capacity will be reduced
- Safe working procedures should be devised for the safe isolation of the electrical supply (including any batteries) and followed by appropriate personnel
- Do not magnetize the lifter before setting it on the load
- Do not attempt to hoist the load until you are satisfied that the magnetic lifter is capable of doing so. Methods of ensuring this will vary from one manufacturer to another and it is essential that the manufacturers' instructions relevant to the particular type of magnetic lifter are consulted. The capability may be checked by inserting a piece of non-magnetic material between the load and the magnet and performing a test lift by raising the load a small distance from the ground. This is called an artificial air gap test
- Ensure the load is balanced. An unbalanced load will tilt and may become detached by slipping

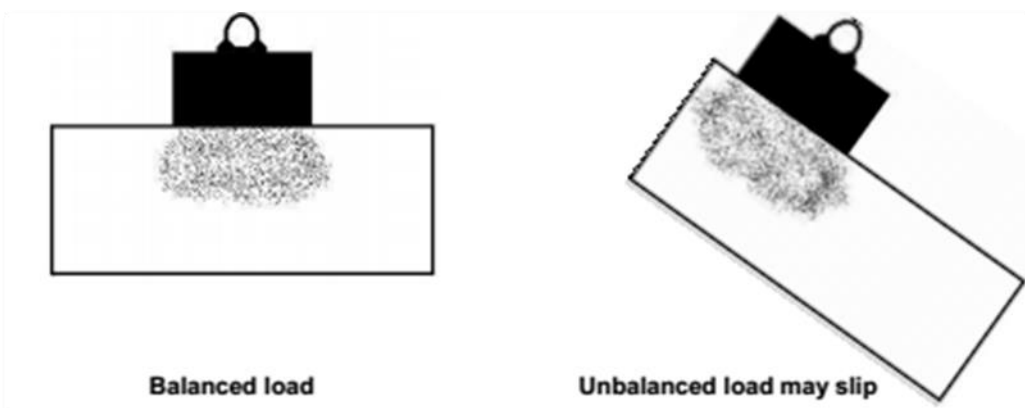

- Be aware that flexible loads can peel off the magnet face. Do not attempt to lift a load if this is likely to happen

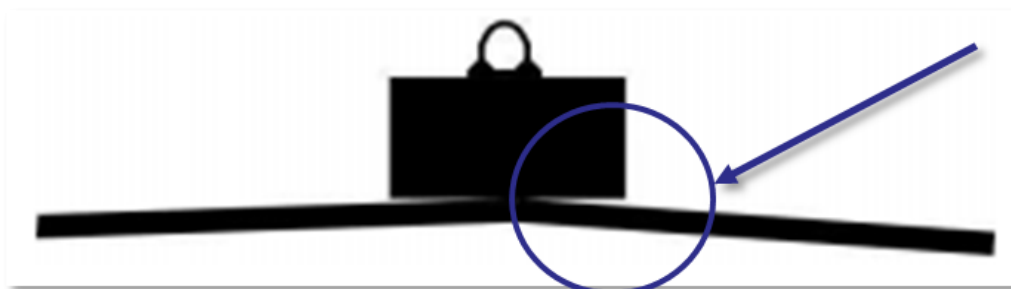

- To overcome this problem, use two or more magnetic lifters in conjunction with a suitable lifting beam or spreader, ensuring that the share of the load taken by each magnetic lifter does not exceed its capacity

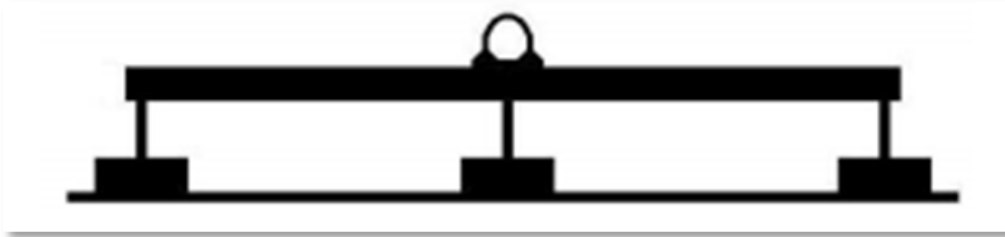

- If the load is comprised of a stack of material, e.g. of steel plates, the magnetic lifter can only lift the material permeated by the magnetic field. For this type of application, magnetic lifters with variable power are required. This facilitates shedding of excess load by reducing the power then securing the remaining load by restoring full power. Without this facility, the lowest part of the stack lifted is likely to be very insecurely held and therefore present a high risk of becoming detached



Porous objects will have a lower density than solid objects made from the same material. This will affect the lifting capacity of the magnet. By comparing the density of the solid material with the bulk density of the porous material the available percentage of the magnet's power may be calculated. See example below:

Bulk density = mass/volume

Solid steel density = 7.8gm/cc and magnet capacity = 100%

Porous steel with e.g. bulk density = 5, therefore magnet capacity = $5/7.8 \times 100 = 64\%$

Loads with internal voids should be treated in the same way i.e. the bulk density should be calculated and the above principles applied.

Ideally, the surface of the load to be lifted magnetically should be flat such that intimate contact with the sole plate of the magnetic lifter is made. An air gap may however be present due to an irregular shape, surface texture or surface coating. If so the capability of the magnet to lift the load should be checked by the artificial air gap test. If in doubt the advice of the manufacturer should be sought. Air gaps are tolerable within the limits laid down by the manufacturer.

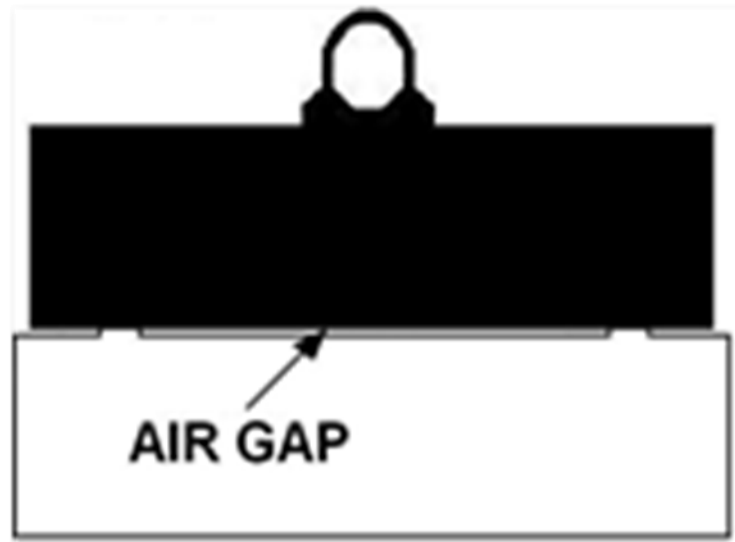

It is possible to lift loads other than those having a flat surface. For example, round sections can be handled by a magnetic lifter with a suitably profiled sole plate. However the lifting capacity will be less than it for a load with a flat surface.

- Always use the entire lifting pole surface
- Ensure that, once hoisted, the load is transported gently to avoid swaying and is not subjected to shock loads
- Except in scrap handling applications, do not attempt to “demagnetize” the magnetic lifter until the load has been set down
- Beware of accidentally picking up other magnetic objects when the magnetic lifter is activated
- Remember to include the self-weight of the magnetic lifter when calculating the total load on the lifting machine

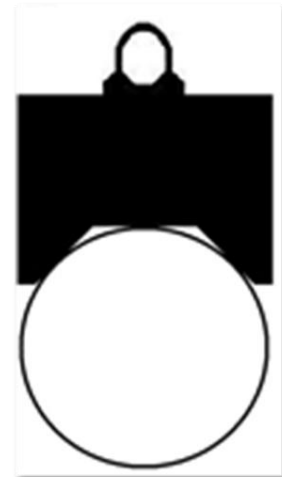

Workers with active body implants (e.g. heart pacemakers or less commonly insulin pumps, defibrillators and nerve stimulators), may be affected by the EMF around magnets.

The worker’s medical specialist should be able to advise them of any risks associated with the implant. However, following the general rule of keeping people clear of the lifting/transporting zone to protect them from any displaced load (during operation), should also ensure that risks from EMFs are reduced to a minimum.

Assessment of exposure during maintenance work may be more complex. BS EN 50527-1:2010 Procedure for the assessment of the exposure to electromagnetic fields of workers bearing active implantable medical devices – Part 1 – General and, BS EN 50527-2:2011 Part 2 Specific assessment for workers with cardiac pacemakers will be helpful in assessing these risks.

Training

Operator training should take into account the manufacturer's instructions and also pay particular attention to the following:

- The limits of the applications for which the particular magnetic lifter has been specified or is otherwise suitable
- The controls, indicators and warning devices of the magnetic lifter
- The precautions to be taken to avoid risk to persons in the vicinity of the lifting operation
- The precautions to be taken when lifting the various types of load such as thin material, low density material and material with poor surface finish
- How to check that the load is securely held, balanced and not at risk of slipping, peeling or otherwise becoming detached

The training should emphasize that magnetic lifters are for use in a limited number of applications and should not be regarded as "general purpose" equipment. For this reason training should cover the fundamentals of safe lifting, the use of magnetic lifters in general and the use of the particular magnetic lifter in the particular application. To do so, it may be necessary to enlist the services of the manufacturer or supplier of the magnetic lifter.

Notes:

Vacuum Lifters

This section covers vacuum lifters which are within the scope of BS EN 13155: 2003 + A2: 2008, Cranes – Safety - Non-fixed load lifting attachments. There are four different types as follows:

- (1) Self actuating
- (2) Mechanically pumped
- (3) Venturi
- (4) Turbine

It does not cover hand held vacuum devices such as those commonly used by glaziers to handle sheets of glass. These are not items of lifting equipment.

Because of the specialised nature of vacuum lifting applications, the advice given in this section of the code should be regarded as general advice which should be augmented by the specialist advice provided by the supplier of the vacuum lifter.

Although some manufacturers offer a standard range of vacuum lifters, unlike other lifting equipment, **they are not usually regarded as “general purpose” equipment.** Vacuum lifters are usually employed in specific circumstances to

lift specific loads. As there is no positive connection between the lifting device and the load, the ability of the vacuum lifter to safely lift a particular load needs to be carefully considered. This will normally involve tests to determine the lifting power of the vacuum lifter on the specific load whilst manipulating it in any way required for the lifting operation.

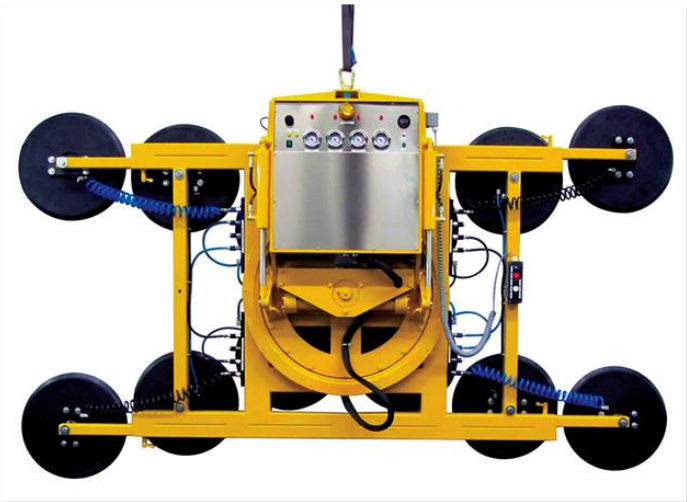

Types of Vacuum Lifter

Self-Priming Vacuum Lifter

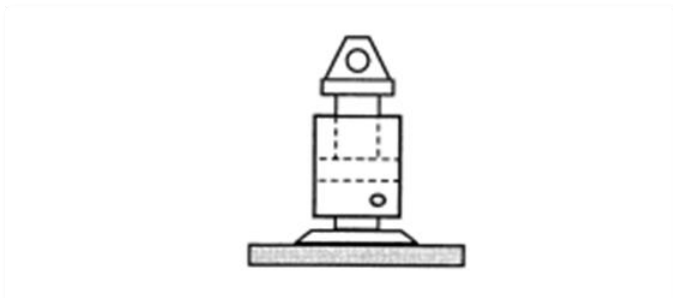

This type of vacuum lifter uses the load being lifted to create the vacuum.

Non Self-Priming Vacuum Lifter

This type of vacuum lifter uses an external energy source to create the vacuum to enable lifting.

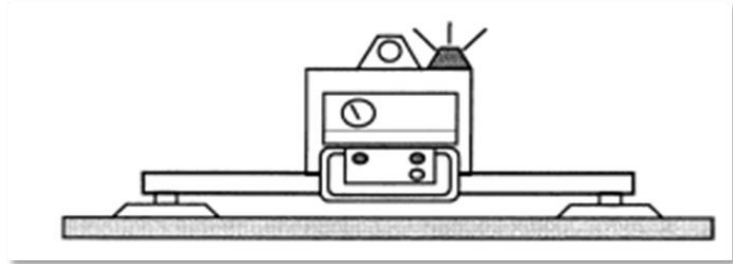

Venturi

When air under pressure flows through a constricted section of pipe, the air velocity increases through the constriction and its pressure drops creating a partial vacuum which can be piped to a vacuum pad.

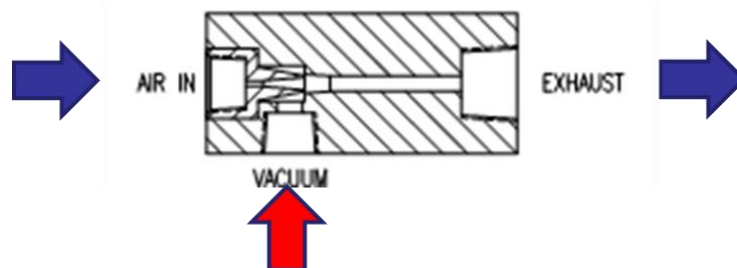
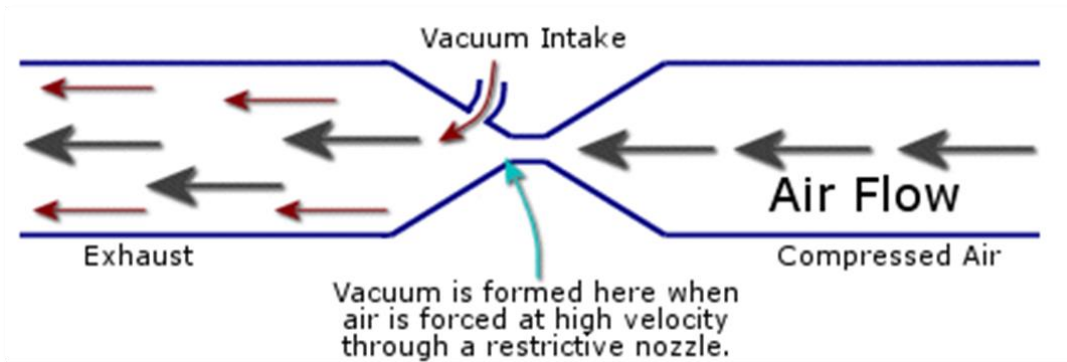

Notes:

Turbine

A machine comprising of a rotor with one or more shaped blades which when rotated will cause suction and this in turn creates a vacuum in the vacuum pad.

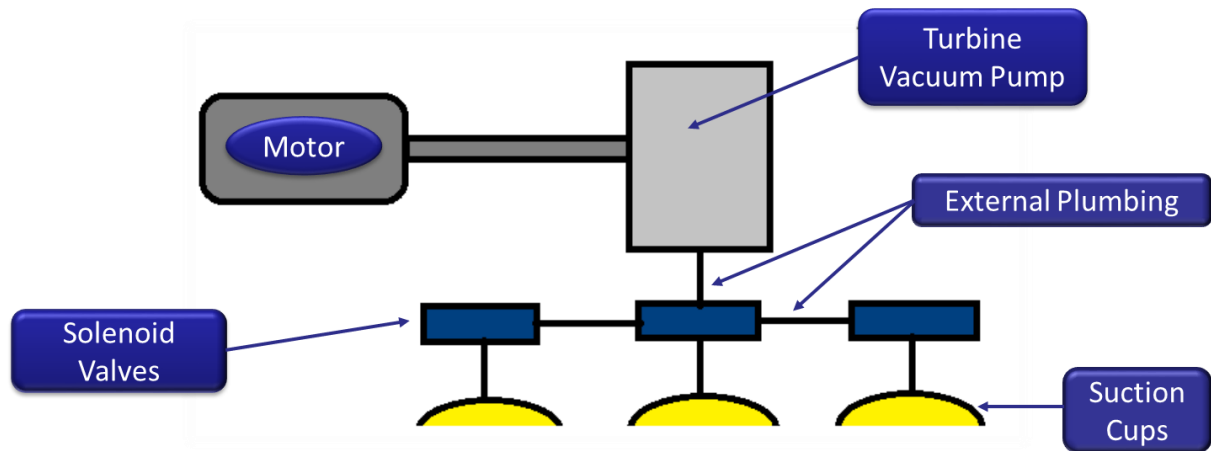

Self-Priming or Self-Actuating Vacuum Lifters

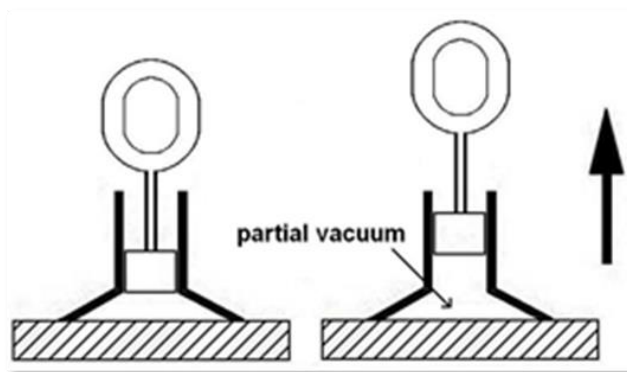

This type of vacuum lifter has an integrated piston and cylinder which creates the vacuum. The vacuum lifter is initially held in contact with the load by its own weight which acts on the flexible seal around the vacuum pad. On hoisting, the piston is pulled up creating a partial vacuum in the cylinder and vacuum pad. The piston moves within the cylinder until the force generated by the vacuum within the cylinder equals

the weight of the load. The vacuum generated is therefore proportional to the weight of the load.

The area of the vacuum pad is greater than that of the cylinder thereby increasing in proportion the adhesive force arising from the vacuum. The self-priming or actuating type vacuum lifters must be equipped with an indicator to show the operator that the end of the working range has been reached. This indicator must be visible to the slinger, or if there is no slinger, to the driver of the crane. To prevent risks due to vacuum losses a reserve stroke capacity of at least 5% of the total stroke of the piston must be provided.

Notes:

Powered Vacuum Lifters

Powered vacuum lifters use a pump to generate the vacuum and are normally electrically operated either by mains or battery. The pump may be housed within the vacuum lifter itself or may be separate, with the vacuum transmitted to the vacuum lifter by means of a hose. They may be equipped with single or multiple lifting pads dependent upon the application.

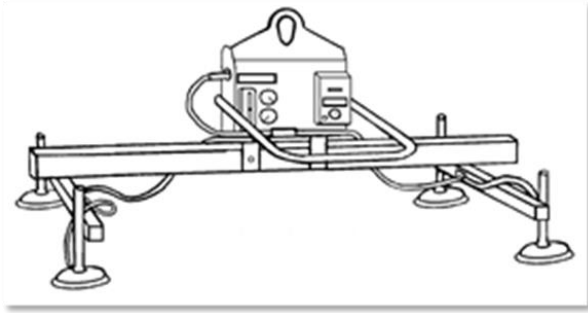

There are three basic types of pump. The piston type has the advantage of generating a high level of vacuum, essential for applications where the size of the vacuum pads must be kept to a minimum. The venturi type has the advantage of simplicity and the facility to be powered by a remote source of compressed air which is useful in applications where the presence of electricity is a hazard. The turbine type produces a relatively low level of vacuum but can pump a high volume of air. The turbine is usually integral with a single large area vacuum pad and the combination of low vacuum and high air volume is an advantage when lifting porous loads and those where the adhesive force must be spread over a large area.

Safety Requirements of BS EN 13155

Vacuum Lifters must be designed to hold at least 2 x WLL at the end of the working range and the beginning of the danger range at all intended angles of use.

“Danger Range”: The range of vacuum levels below the working range but which is still capable of holding the load.

The maximum tilt shall be designed for an angle exceeding minimum 6 ° the maximum working angle. Attachments not intended to tilt shall be designed for an angle of minimum 6 °.

Non self-priming vacuum lifters must incorporate a pressure measuring device showing the working range and danger range of the vacuum.

Self-priming vacuum lifters must be equipped with an indicator that shows the operator that the end of the working range is reached. This has to be clearly visible to the slinger or crane driver (if no slinger is present).

Powered Vacuum Lifters

Powered vacuum lifters must also be equipped to prevent the risks arising from vacuum losses. Where a vacuum pump is used, a vacuum reservoir with a non-return valve fitted between the reservoir and the pump must be provided.

Where a venturi is used, a pressure reserve tank or a vacuum reservoir with a non-return valve between the system and the tank or reservoir must be provided. For a turbine system, a supporting battery or an additional flywheel mass must be provided.

Note: In the case of a power failure, the vacuum lifter must be able to hold the load for 5 minutes.

This is not necessary in 'no go' areas where persons are excluded from the danger zone. It is also not necessary for turbine types provided that the operator controls the load through steering handles which ensure that the operator is outside the danger zone, the height of lift is restricted to a maximum of 1.8m and a warning sounds as soon as the power fails.

Lifting Loads above People

For powered vacuum lifters used to lift loads over areas where persons are present, e.g. on a construction site, a secondary positive holding device which can be deployed to secure the load is required or there must be a duplication of the vacuum systems including the vacuum reservoirs and vacuum pads.



The release of the load must be actuated by a two action control unless the vacuum lifter is being used in a 'no go area' or release is not possible until the load has been set down.

Vacuum Pads

The shape of the vacuum pads should be matched to the load to be lifted and if more than one vacuum pad is being used, the share the load imposed on each vacuum pad must not exceed the working load limit of the individual vacuum pad.

For vacuum lifters with the facility to orientate the load, the controls for tilting or turning the load must be the hold to run type.



Marking

The following information should be permanently and legibly marked on a suitable part of the vacuum lifter unless the vacuum lifter is a permanently installed component of a larger lifting appliance in which case the appliance itself may be so marked:

- (1) Identification mark
- (2) CE mark
- (3) Working load limit
- (4) Name of manufacturer
- (5) Year of manufacture
- (6) Self weight of the vacuum lifter if it exceeds 5% of the WLL or 50 kg, whichever is the less
- (7) On self-priming vacuum lifters, the minimum load
- (8) On turbine vacuum lifters where the holding time in the event of power failure is less than 5 minutes, the following warning: Warning, Load must not be lifted above 1.8 m

In-Service Examination

In addition to the thorough examination required under LOLER, all vacuum lifters should be visually inspected by a responsible person prior to use or on a regular basis taking into account the conditions of service.

This inspection should include an operational check of all the controls and indicators of the vacuum lifter and a visual check for mechanical damage. It is usually carried out as part of a “test lift” which may typically be the first lift of a shift, day or other period of work. For battery operated models it is also necessary to check the condition of the battery and its state of charge.

If any of the following faults are present the vacuum lifter should be withdrawn from service and referred to a Competent Person:

- General damage to the body of the vacuum lifter
- Damage to the lifting eye or other means of suspension
- Damage or contamination of the vacuum lifting pads
- Failure or dysfunction of any operating controls, warning lights or other warning devices
- Missing or illegible markings, model, manufacturer, serial number, load rating information etc.
- Air leaks from any hoses or couplings

Thorough Examination

The definitions of lifting equipment and accessories used in The Supply of Machinery (Safety) Regulations make it clear that a device used to connect a load to a lifting appliance is a lifting accessory and should be supplied with an EC Declaration of Conformity.

A vacuum lifter is therefore a lifting accessory and the Lifting Operations and Lifting Equipment Regulations state that they must be examined by a Competent Person at intervals not exceeding 6 months.

The EC Declaration of Conformity and the Reports of Thorough Examination should be retained and cross referenced to the vacuum lifter's records for inspection by the Competent Person or HSE.

For some applications it may also be necessary to have the installation thoroughly examined by a Competent Person before the vacuum lifter is put into service. This may be necessary in order to ensure that the operation of the lifter in practice complies with the theoretical predictions.

Vacuum lifting devices are not suitable for the lifting of persons so normally they would only require a twelve-monthly thorough examination when permanently attached to a crane or lifting machine.

However, in those circumstances where there is a high intensity of use, more frequent thorough examinations may be necessary. For example, if the crane, or lifting machine, with the vacuum lifting device as a whole is used many times in a working shift and is used to carrying loads close to the safe working load of the crane or lifting machine and vacuum lifting device.

Visually check the structure of the vacuum lifting device for damage or signs of cracking, distortion and corrosion etc.

- Visually check all bolted or other fastening connections to ensure they have not worked loose
- Visually check the attachment point(s) for attaching the vacuum lifting device to the crane or lifting machine for damage, wear, cracking, corrosion and free movement of any swivels etc.
- Visually examine all pipes and flexible hoses for damage and leakage
- The vacuum motor and pump should be visually examined for damage
- The vacuum suction pads should be visually examined for security and damage ensuring that there are no cuts, tears or other damage, which would prevent an effective vacuum.
- The electrical power supply to the vacuum system should be visually checked for damage and wear ensuring that there is no access to live conductors
- Ensure that all controls (levers, buttons etc.) are marked with their function and mode of operation
- Functional test of all controls (levers, buttons etc.) should be carried out to ensure smoothness of operation and freedom from wear and other damage. Ensure as appropriate that controls return to neutral when released

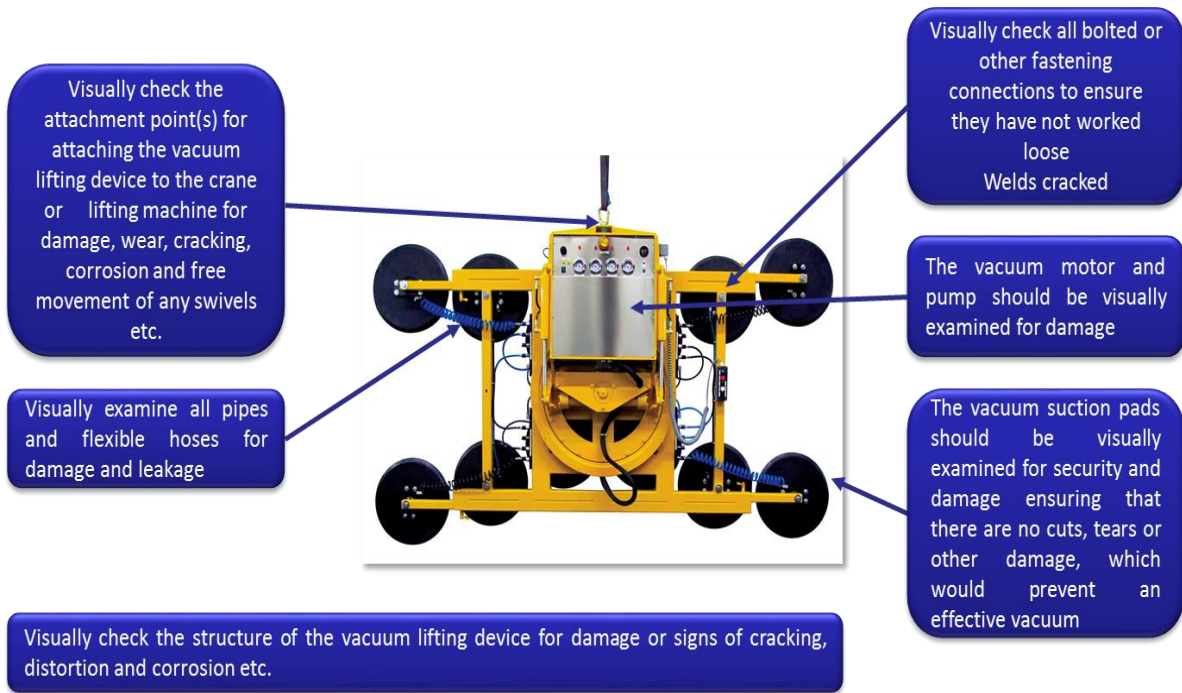

After carrying out all necessary examinations carry out a functional test on the vacuum device ensuring that the vacuum system is effective by attaching a suitable load within the safe working load

A visual check shall be made to ensure the vacuum lifting device and the crane or lifting machine is marked with their compatible safe working loads

Ensure that warning signs and other important manufacturer's instructions are present and readable e.g. rating plate



Crane Forks and C Hooks

The current Harmonised Standard for Crane Forks and C Hooks is **BS EN 13155**, Cranes – Safety – Non –fixed load lifting attachments.

Clause 5.2.4 gives the specific requirements C-hooks must meet

Clause 5.2.5 details crane lifting forks

Crane forks are suspended from a lifting appliance (in most cases from an overhead travelling crane) and are used mainly for lifting palletised loads.

Crane forks can be supplied as self-levelling or manually adjustable.



C Hooks (named from their notable shape of the letter 'C') are also suspended from a lifting appliance. The C hook is mainly used for lifting coils of material such as steel rod and steel sheet without damaging the material.

C Hooks are normally levelled by the use of a built in counterweight.

Crane Forks

- Lift palletised, or similar loads
- Loads suspended from a crane hook
- Fabricated from hollow section box, plate and flat steel sections
- The type shown here requires the operator to position the suspension fitting, usually a link or shackle
- Must be in correct position to balance the load at the correct attitude
- Fork arms usually have adjustable centres for handling varying loads



C Hooks

- Lift hollow loads i.e. pipes, coils of steel
- Top arm of the 'C' fitted with a counterweight
- Lower arm of 'C' may have an end stop
- Ensures hook maintains a slight upward stance when suspended under load
- Will return to unloaded position when load is removed
- Allows easy engagement with load and prevents load slipping off during lifting and moving



Notes:

Crane Forks – Adjustment for Balance

Some crane forks are designed where the position of the lifting eye can be manually adjusted along the length of the cross member to facilitate lifting loads where the position of the centre of gravity may vary. Other crane forks where the position of the lifting eye is automatically adjusted to facilitate lifting loads where the position of the centre of gravity may vary.

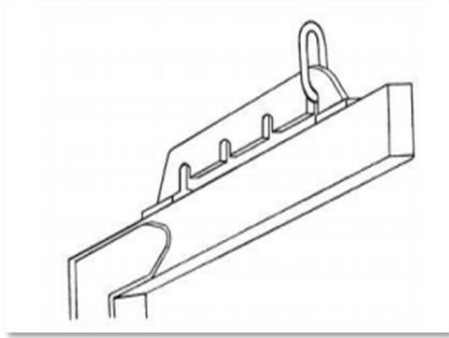

Manual (by operator)

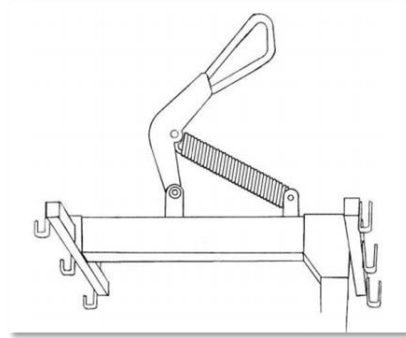

Automatic (spring mechanism)

Safety Requirements of BS EN 13155

Mechanical Strength

Crane forks and C-hooks must be designed to withstand a static load of 2 times the WLL without any deformation taking place and with a static load of 3 times the WLL without release of the load even if permanent deformation occurs.

Positioning Handles

To enable the operator to position the crane fork or C-hook without the risk of finger injuries, positioning handles must be fitted in an appropriate position unless the design has features that will provide natural hand-holds.

Unloaded Attitude

Crane forks and C-hooks must be designed so that they hang when unloaded with the fork arms or bottom leg of the 'C' within 5° of the horizontal. This is so that they can easily engage with the load.

Notes:

Unintended Load Displacement

The design must incorporate features to prevent the load sliding and becoming displaced or falling. Various ways of achieving this are given in the standard, however the choice will largely depend on the nature of the load to be lifted and the intended lifting operation.

In the case of C-hooks, the most common method used is that the hook adopts a backward tilt to the horizontal in the loaded condition. The end of the lower arm is then shaped to act as a stop or fitted with a stop.

In the case of crane forks the requirements are slightly different as the load is often made up of loose items, e.g. bricks, stacked on the pallet and steps have to be taken to ensure they are captive during the lift so that they do not fall. The forks must adopt a backward tilt when in the lifting position.

Loose Materials

Where loose materials are to be lifted, e.g. bricks, there should be a secondary load holding device, such as a net or cage, capable of holding a uniformly distributed load equal to 50% of the WLL in all four horizontal directions. Openings in the mesh must not be more than 50mm square to prevent small items falling through.



When unit loads are to be lifted, e.g. a plastic wrapped palletised load, a retaining device should be fitted, e.g. a chain, strap or bar, which will prevent the load sliding off the forks.

Notes:

Marking

BS EN 13155 requires lifting crane forks and C-hooks to be permanently and legibly marked with the following minimum information:

- Name and address of the manufacturer
- Model identification
- Serial number (identification mark)
- Year of manufacture
- WLL
- The self-weight of the crane fork or C-hook if it exceeds 5% of the WLL or 50kg.
- The limits of the intended position of centre of gravity of the load.
- Additionally in the case of crane forks where a minimum load is necessary to tilt the fork – the minimum load
- Mandatory markings, e.g. CE mark (where applicable)

The additional information is necessary for crane forks where the tilt is spring assisted as action of the weight is necessary for the mechanism to operate correctly.

247

Manufacturers Tests

Type Verification

EN 13155 requires the manufacturer of lifting crane forks and C-hooks to carry out various type tests to prove the design on one or more samples. These include:

a) Verification of the mechanical strength. The manufacturer has a choice;

1) This may be done by calculation alone, or 2) it may be done by a static test as follows:

A static overload test at 3 times the WLL ($\pm 2\%$) which replicates the conditions of use, held for a period of 1 minute. The load must be held even if there is permanent deformation.

b) Verification of the tilting limit. A test load equal to 3 times the WLL must be applied in such a way that the lines of force through the suspension point will vary to replicate the tilt in several positions to simulate the worst operational conditions. There must be no release of the load even if permanent deformation occurs.

c) Additionally in the case of crane forks, verification of the mechanical strength of the secondary holding device in horizontal direction. A static force equal to half the WLL on the 90° tilted fork must be applied to the lower half of the secondary holding device. The test must be repeated in at least 2 of the most unfavourable directions. The device must hold, even if there is permanent deformation.

On completion of manufacture each lifting crane fork or C-hook must be verified as follows:

- The manufacturer has a choice, he may either confirm the mechanical strength by calculation or by a static load test equivalent to 2 times the WLL

Followed by:

- Thorough examination

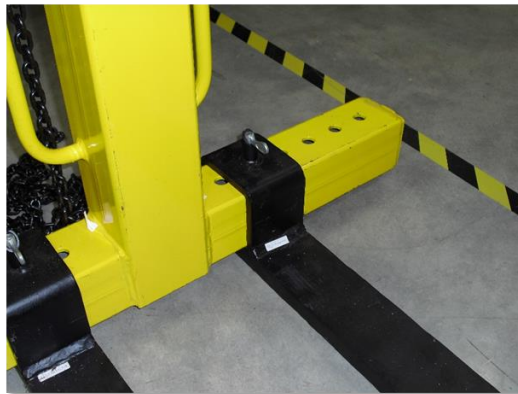

Pre-Use Inspection

In addition to the thorough examination required under LOLER, all crane forks should be visually inspected by a responsible person prior to use or on a regular basis taking into account the conditions of service.

This inspection should involve a check of all parts of the crane fork. If any of the following faults are present the crane fork should be withdrawn from service and referred to a Competent Person:

- General damage to the fork arms, mast or cross member
- Damage to the lifting eye or other means of suspension
- Damage to the adjustment mechanism if fitted
- Missing or illegible markings, model, manufacturer, serial number, load rating information etc

Notes:

Load Testing (As Part of the Thorough Examination)

The requirements for load tests to be made as part of the examination will vary dependent on the circumstances. If a structural repair has been made a load test may be deemed necessary, but great care will be needed to ensure that any load is applied correctly so as not to damage the crane fork or C-hook. We should also bear in mind that in most circumstances a load test will serve no purpose as the strength of the crane fork or C-hook is already known. Further, repetitive overload testing will shorten their working life.

Where load testing is deemed necessary, before any load is applied, the manufacturer's instructions must be obtained and then strictly followed. Under no circumstances should the tester and examiner apply an overload without taking these steps to establish the correct load as damage or distortion may result.

Thorough Examination

The definitions of lifting equipment and accessories used in The Supply of Machinery (Safety) Regulations make it clear that a device used to connect a load to a lifting appliance is a lifting accessory and should be supplied with an EC Declaration of Conformity.

Crane forks and C hooks are therefore lifting accessories and the Lifting Operations and Lifting Equipment Regulations state that it must be examined by a Competent Person at intervals not exceeding 6 months.

The EC Declaration of Conformity and the Reports of Thorough Examination should be retained and cross referenced to the crane fork's historical records for inspection by the Competent Person or HSE.

Following repair, crane forks and C hooks must be re-verified by a Competent Person. The record of the repair and report of verification should be retained and cross referenced to the crane fork's historical records for inspection by the competent person or HSE.

Notes:

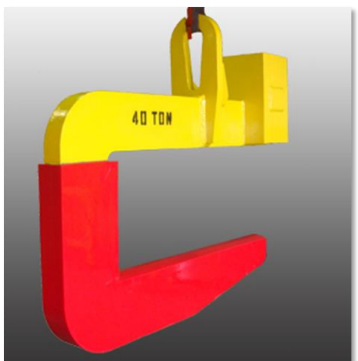
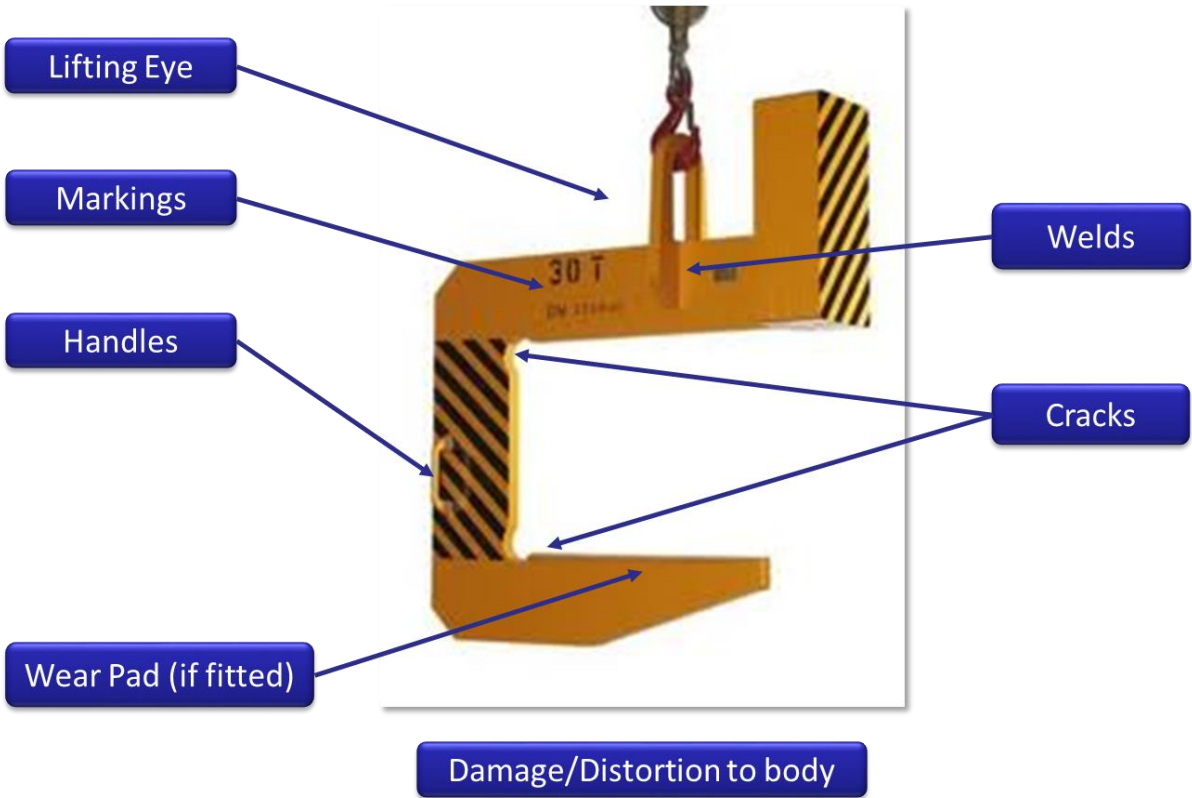

C Hook with Wear Pad

Damage to Secondary Holding Device



Notes:

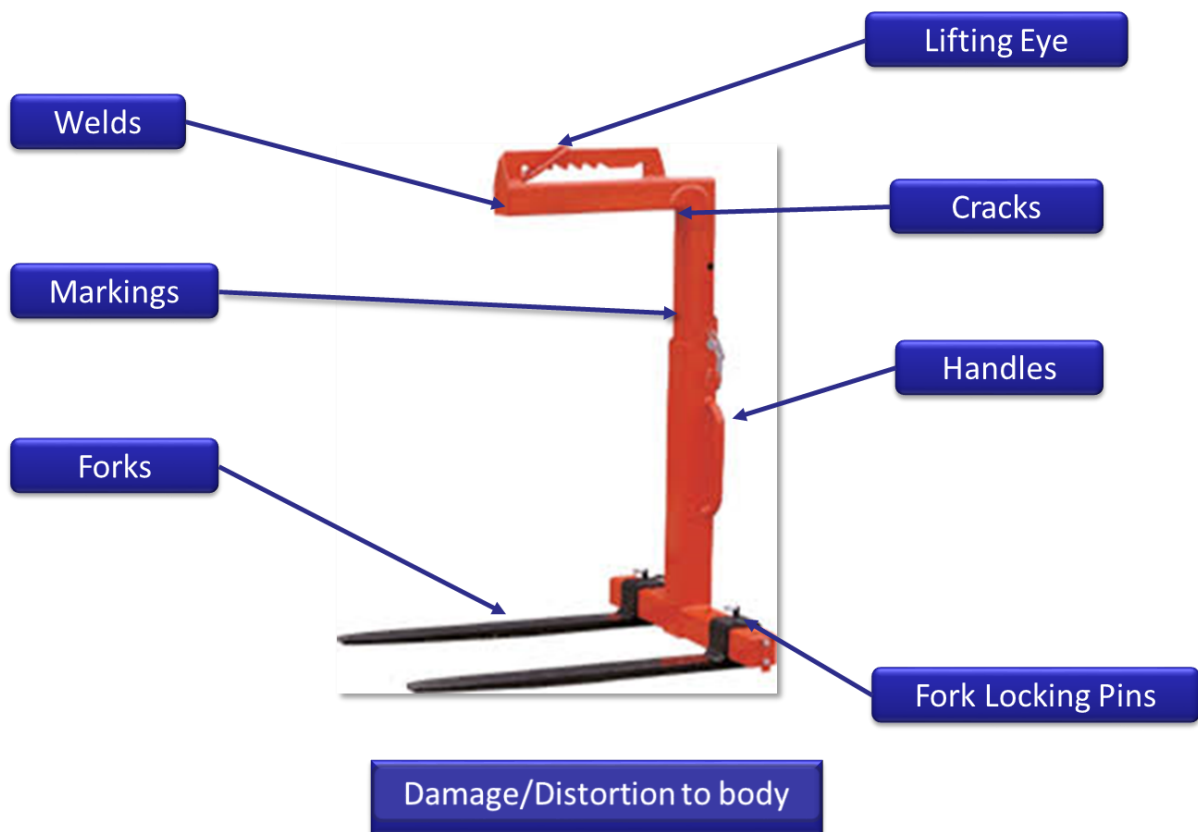

The general appearance of the crane fork or C-hook should be considered during the examination, in particular paying attention to the following:

- Bending and distortion, mechanical/physical damage and corrosion of the structural members. In particular attention must be paid to hollow sections which may have dents or localised buckling, to the flanges of structural rolled steel sections and to plate sections which may be bent
- Fixings and welds. Welds and adjacent areas should be examined for cracks, bolts and rivets examined for wear, distortion, corrosion, damage and tightness
- Lifting eyes, load attachment points etc. looking for wear, distortion, elongation of eyes and other physical damage
- In the case of crane forks with spring assisted tilt mechanism, the condition and correct working of the spring
- In the case of C-hooks, for many applications the load bearing surface of the hook is of its' fixing

Information which should be exchanged between the user and the designer or supplier

Crane forks may be used for specific applications or for a variety of similar applications. It is therefore usually possible to give the designer or supplier precise or general details of the tasks to be performed. This information should include but is not necessarily limited to the following:

- The minimum and maximum mass of the load to be lifted
- The size and type of pallet or coil to be lifted or, if self-palletised, the position of the fork arm apertures and method of securing the load elements e.g. the load to be lifted
- The make up of the load to be lifted, i.e. banding, wrapping
- The physical dimensions and shape of the single object or multiple objects, and if multiple, the method of securing them, e.g. building blocks secured by shrink wrap
- The type of suspension, i.e. fixed, manual or automatic adjustment
- The available headroom
- The control features required, e.g. grab handles
- Details of the operating environment and service conditions, e.g. extremes of temperature, probability of shock loading, uncertainty of mass of the load
- Other safety features required, e.g. secondary positive holding device, wear pads

Safe Use of Crane Forks and C Hooks

Most C-hooks are designed for a specific purpose and should not be used for other lifts without reference to the manufacturer, or someone able to make the necessary checks and calculations, as the C-hook may be overloaded or subject to adverse stress. This can result in the C-hook becoming bent, twisted and distorted or in welds becoming cracked or failing.

Care must be taken to ensure that the load sits correctly on the C-hook or lifting forks. The back edge of the load should sit against the back of the C-hook or forks so that the C of G of the load acts through the correct position or the assembly may become unstable. If the C of G of the load is towards the front of the C-hook or forks the tilt may be affected and could lead to the load slipping and falling, or in the lower arm of the C-hook or forks being overloaded and becoming bent, twisted and distorted or welds cracking and failing.

Care must be taken to ensure the C-hook or crane forks are not subject to a sideways loading. This can lead to twisting and distortion or in welds becoming cracked or failing and in the case of forks with a spring assisted tilt mechanism the spring can become damaged.

When placed in storage, care must be taken to avoid any mechanical damage occurring. In the case of forks with a spring assisted tilt mechanism, it is essential that steps are taken to avoid corrosion of the spring and that it is suitably lubricated.

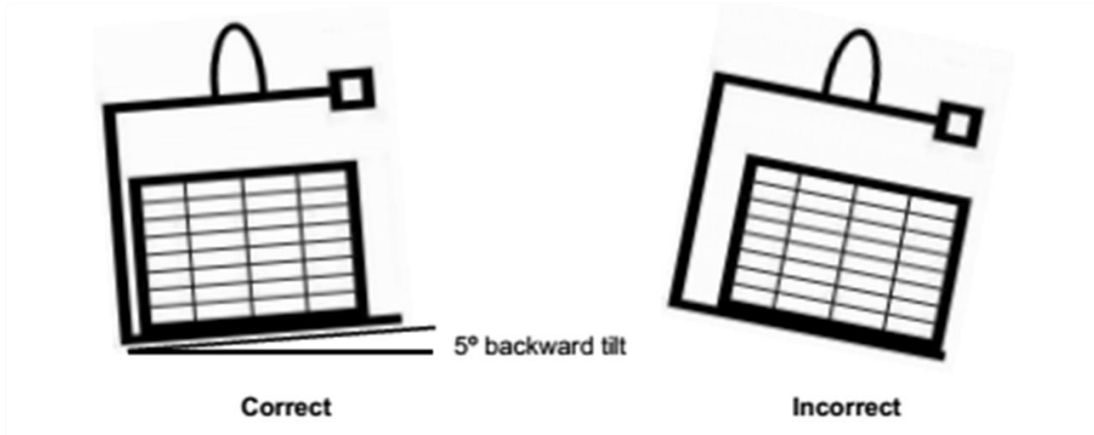

Check that the load hangs correctly

Training

Operator training should take into account the manufacturer's instructions and also pay particular attention to the following:

- The limits of the applications for which the particular crane fork has been specified or is otherwise suitable
- For manually adjusted crane forks, the method of adjusting the balance.
- For automatically adjusted crane forks the minimum load if any
- The precautions to be taken before lifting if the load comprises loose material
- The precautions to be taken when lifting over people in the danger zone including correct fitting of the secondary positive holding device
- How to check that the load is securely held, and correctly balanced

The training should emphasize that crane forks are for use in a limited number of applications and should not be regarded as "general purpose" equipment. For this reason training should cover the fundamentals of safe lifting, the use of crane forks in general and the use of the particular crane fork in the particular application.

We would be grateful for your feedback regarding these Step Notes, after completing this training course. Please make your comments known to your LEEA Facilitator – you can use the note box below to list anything you would like to bring to our attention.

We value your views and will use your comments to help our continual improvement of our learning and development materials.

Thank you in advance for your participation.

Andrew Wright
LEEA Learning and Development Manager

Step Notes - verbal feedback to LEEA: